



सत्यमेव जयते

# **SPACE FOR ELECTRICAL AND MECHANICAL SERVICES IN BUILDINGS**

**COMPANION VOLUME OF GENERAL SPECIFICATIONS FOR  
ELECTRICAL WORKS**

# **2013**



**CPWD**

**PUBLISHED UNDER THE AUTHORITY  
OF  
DIRECTOR GENERAL, CPWD, NEW DELHI**

## **FOREWORD**

1. It is important to provide proper space for various E&M services at preliminary stage itself in coordination with the architect. However, it is seen in many cases, space provided for various E&M services are inadequate and in few cases they are in excess. Sometimes, some services have been left out. Based on feedback received from a number of projects, a uniform standard has been prepared.
2. The enclosed norms are intended only to serve as guidelines, and should not come in the way of modifications / improvements or different approach as required for specific applications as per the judgement of planning engineers.
3. Suggestions / comments will be gratefully received.
4. I appreciate the efforts put in by Shri J. K. Choudhury, Chief Engineer (E) for preparation of this Booklet.
5. This has been approved by 38th Specification Committee held on 9th/10th October, 2002 vide agenda Item 30.0.5.

**C. K. VARMA**  
**CHIEF ENGINEER (E) CSQ**

# INDEX

	<i>Page No.</i>
1. Introduction	1
2. Sub-Station	1
3. Wet Riser and Water Supply Pump House	3
4. Lifts	4
5. Fire Control Room / Telephone Room	4
6. Air Conditioning	5
7. Shafts	6
8. Cable Entry Pipes	7
9. SDBs	7
10. False Ceiling in Corridor	7
11. False Ceiling in Rooms	7
12. Check List	7

## ANNEXURES

Annexure I	Electric Sub-Station cum Fire Pump House	9
Annexure II	Electric Sub-Station Building	10
Annexure III	Electric Sub-Station cum AC Plant	11
Annexure IV	U.G. Wet Riser Pump Room for Positive Suction	12
Annexure V	Pump Room for Wet Riser cum Water Supply	13
Annexure VI	Fire Fighting and Domestic Water Storage Tank	14
Annexure VII-A	Dimensions of Passenger Lifts	15
Annexure VII-B	Dimensions of Goods Lifts	16
Annexure VII-C	Dimensions of Hospital Lifts	17
Annexure VII-D	Dimensions of Service Lifts	18
Annexure VIII	Electrical Rising Main / Wet Riser Shafts	19
Annexure IX	Telephone / Fire Alarm Shafts	20
Annexure X	Rolling Shutter	21
Annexure XI	Wet Riser Shaft Door Details	22
Annexure XII	Electrical / Telephone / Fire Alarm Shaft Door Details	23
Annexure XIII	Window / Ventilator Design .	24
Annexure XIV	Structural Details for AC Plants	25
Annexure XV	Water Requirement for Fire Protection with Wet Riser/Down Corner System	27
Annexure XVI	12 Minimum Fire Safety Measures as per National Building Code	28

# SPACE FOR ELECTRICAL AND MECHANICAL SERVICES IN BUILDINGS

## 1. INTRODUCTION

E&M services generally provided in a building:

- (a) Electric sub-station, power distribution system.
- (b) Generating sets.
- (c) Lifts.
- (d) AC plant including central plant, package plant, split /window AC units.
- (e) Ventilation system.
- (f) U.P.S. / Voltage stabilizer.
- (g) Water supply pumps.
- (h) Wet riser system for fire protection.
- (i) Fire detection, alarm, PA system for fire protection.
- (j) Communication system.
- (k) Computer cabling and allied works.
- (l) Building security system including CCTV, access control, burglar alarm system.
- (m) Building automation system.
- (n) External lighting, road lighting, compound lighting, garden lighting, area lighting, high mast lighting and other specialised lighting.
- (o) Auditorium lighting, acoustics, stage lighting and sound system.
- (p) Swimming pool equipments etc.

All these services require close coordination between civil, architectural and electrical wings right from conceptual stage. Unless proper space is provided for these services, they can't be provided at construction stage without adversely affecting the aesthetics of the building and functional efficiency of the services. Many services can't be provided at all in absence of proper planning of space for various E&M services.

## 2. ELECTRICAL SUB-STATION

### (a) Space for:

HT panel (both supply and CPWD).

Transformers.

L.T. panel.

Essential L.T. panel.

Power factor correction panel.

Generating sets.

P.O.L. Store / other store.

Supervisor room, toilet, workers rest room.

HT voltage correctors.

Voltage stabilizers.

UPS system including battery room.

Other equipments as required.

(b) Ventilation.

(c) Approach road around Sub-station.

(d) **Extract of Table A & B of Appendix IV of CPWD Electrical Specification Part IV (Sub-station) 2013**

#### ***Area for Sub-Station***

The minimum sub-station and transformer room area required for different capacities are tabulated for general guidance. Actual area will however depend upon the particular layout and site constraints.

The clear height required for Sub-station equipments shall be a minimum of 3.6 m.

**TABLE 1**

<i>Sub-Station with transformer capacity of</i>	<i>Total transformer room area required</i>	<i>Total sub-station area required i/c HVMV panel transformers but without generators</i>	<i>Suggested minimum face width</i>
2*500 kVA	36.00 sqm	130.00 sqm	14.5 m
3*500 kVA	54.00 sqm	172.00 sqm	19.0 m
2*800 kVA	39.00 sqm	135.00 sqm	14.5 m
3*800 kVA	58.00 sqm	181.00 sqm	19.0 m
2*1000 kVA	39.00 sqm	149.00 sqm	14.5 m
3*1000 kVA	58.00 sqm	197.00 sqm	19.0 m

#### ***Area for Generating Sets***

Additional area that is required for one generator is given below:

**TABLE 2**

<i>Capacity</i>	<i>Area</i>
25 kW	56.00 sqm
48 kW	56.00 sqm
100 kW	65.00 sqm
150 kW	72.00 sqm
248 kW	100.00 sqm

The clear height required for the generating set room shall be a minimum of 3.6 m upto 100 kW capacity and 4.57 m for higher capacities.

**(e) Location of Sub-station:**

- (i) Avoid basement due to likely flooding during rains (there is hardly any basement sub-station/ AC plant, which is not affected by substantial damage due to flooding).
- (ii) No parking in front of transformer and other equipments.
- (iii) Easy approach to equipments.
- (iv) Closer to the electrical load center and preferably in the ground floor.

**(f) Future Expansion:**

The sub-station design should take into account reasonable augmentation of equipments in future.

**(g) Security Precaution:**

Sub-station is the heart of electrical system. Wherever required, security measures like boundary wall and lockable gate may be provided so that unauthorized entry to sub-station can be prohibited.

***Annexure I, II & III for Sub-Station may be seen.***

**3. WET RISER & WATER SUPPLY PUMP HOUSE**

Preferable to have underground pump house by the side of U.G. water reservoir to ensure flooded suction. Water supply pump sets to be combined. Provide suitable ramp approach 1.5 m wide with suitable slope for easy access of heavy equipments and inspection personnel.

Roof slab may be 500 mm above ground level with ventilators. Provide suitable water proofing to prevent seepage of water into pump house.

Preventive measures to be taken so that during heavy rains, rainwater does not get into pump house.

Extract of Para 1.3.3 of CPWD Specifications Part V: Wet Riser System for Fire Fighting:

***Location and Requirements***

***(a) Under Ground Static Storage Tank and Pump House:***

Following aspects shall be considered in deciding the location of the underground static water storage tank and the wet riser pump house :

- (i) Easy accessibility for fire fighting operations.
- (ii) Proximity of fire pump house to the static tank.
- (iii) Ease in bringing and removing equipments.
- (iv) Pump house not being prone to flooding by rainwater, subsoil water.
- (v) Protection of the pump house from any falling masonry and the like occasioned by fire.
- (vi) Adequate ventilation for engine aspiration and to limit the temperature rise in pump house on continuous operation.
- (vii) Aesthetics.

To protect the pump house, it should preferably be located atleast 6 m away from the building. Where this is not possible, this shall be enclosed with suitable masonry structure as a part of the building to prevent spread of fire into the pump room and provide safe operation.

The fire pump house should be located such that the suction for the pump is flooded. Where this is not practical, the pump house may be constructed with negative suction for pump, with suitable automatic priming arrangement. The size of the fire pump house should be 5.5 m x 8 m x 3.5 m, where engine driven fire pump, electric motor driven fire pump and pressurization pump are installed.

The capacity and design of the static tank shall be in accordance with the provisions of National Building Code Part IV - Fire Protection and the local Bylaws as applicable. (See Appendix -II of CPWD Specification Part-V).

***Annexure IV, V & VI for Pump House & Tank may be seen.***

***(b) External Piping and Hydrants:***

External hydrants shall be located within 2 m to 15 m from the building to be protected such that they are accessible and may not be damaged by vehicles. A spacing of about 45 m between hydrants is generally adopted.

***(c) Internal Riser and Hydrants:***

Normally one wet riser is required for every 1000 sqm of covered area. However, the maximum distance that can be served shall be 30 m from the riser.

#### **4. LIFTS**

Check Sizes As Per B.I.S.

**(a) Capacity & number of lifts.**

(A minimum capacity of 13 passenger lift for office bldg. and 8 passenger lift for residential building). Ensure provision of goods lift.

**(b) Lift well size.**

**(c) Pit depth.**

**(d) Machine room size.**

**(e) Over head.**

**(f) The floor of lift machine room shall be designed for a uniform load of 1000 kg/sqm.**

**(g) Lift pit to be water proofed.**

**(h) No structural member intrusions into lift well, like column, beam projections which compromise lift well dimensions.**

***Annexure VII-a, VII-b, VII-c, VII-d may be seen.***

#### **5. FIRE CONTROL ROOM / TELEPHONE ROOM**

**(a) Telephone room: 4 m x 3 m.**

**(b) Fire control room: 4 m x 3 m preferable location near entrance lobby.**

**Note:** Fire control room is a statutory requirement as per national building code.

***Annexure IX may be seen.***

**6. AIR CONDITIONING**

(a) Air-conditioning is maintenance of specified inside conditions: temperature, relative humidity, air changes and air quality.

Air-conditioning also includes winter heating and clean air system.

(b) Depending upon specific requirements, following systems of air-conditioning are followed:

- (i) Window type AC Units.
- (ii) Split type AC Units.
- (iii) Package type AC Units.
- (iv) Central AC System.

(c) Their brief applications are as below:

- (i) *Window type Units*: Suitable for individual isolated rooms. Consumes very high amount of power. No relative humidity control. Very little control over air quality. Suitable for area upto 100 Sqm.
- (ii) *Split Units*: They are same as window type units, except that the compressor units are located away from evaporator (fan) units. The noise of compressor is kept away. Energy wasteful.
- (iii) *Package type*: They are mini and compact central plants available up to 10-Ton capacity. This system is suitable for areas between 100 to 1000 sqm.
- (iv) *Central AC Plants*: They are suitable for large areas. Excellent control over temperature, humidity, clean air, air changes, noise control, uniform distribution and have energy efficiency. A properly designed central AC system will be reliable, effective and efficient. Hence for air-conditioning areas in excess of 1000 sqm, central AC plant is preferred.

(d) Comparison of Systems

**TABLE 3**

	<i>Normal Life</i>	<i>Energy Consumption Index</i>	<i>Humidity Control</i>	<i>Air Changes</i>
Central AC Plant	20 Yrs	100	Yes	Yes
Package Plant	10 Yrs	130	Yes	Yes
Split/ Window AC Unit	7 Yrs	150	No	No

The central plants are designed with suitable standby systems to give reliable service. Properly designed buildings also will reduce ingress of heat, hence the heat load also is reduced by as much as 25%, in case of central plant.

For example, a properly designed building with 200 ton AC load, working 8 hr/day, 250 days/ year will consume approximately 4 Lac units of electricity per year which comes to Rs.16 Lac/year. If the same building is air-conditioned with window type AC units/ split type units, without proper insulation of the building, the energy cost is likely to be 60% more.

- (e) The space & structural requirements for air-conditioning works vary considerably with the systems adopted. It is therefore advisable to study individual cases and decide accordingly in consultation with the manufacturers, if necessary. However, a general guideline is given in Annexure XIV for the purpose of preliminary design/ drawing.
- (i) Space for:  
A/C plant room, cooling tower, make up water tank, air handling units, shaft for chilled water lines.
  - (ii) Shaft, space, false ceiling for ducts, air tightness of doors & windows in air-conditioned areas & AHU rooms.
  - (iii) Clear height of 3.4 m in corridor/ air conditioned space, as the case may be to accommodate supply air duct and return air path.
  - (iv) Thermal insulation of ceiling and walls of air-conditioned area/ AHU rooms wherever necessary.
  - (v) Acoustic insulation for AHU rooms.
  - (vi) Co-ordination of false ceiling work.
  - (vii) Availability of water supply for cooling towers.
  - (viii) Ventilation of AC plant room.
  - (ix) Approach road around plant room.
  - (x) Drainage of AHU room, fresh air opening in AHU room.
  - (xi) Opening for WT AC units. (Annexure XIII).
  - (xii) Space for split AC condensing units and route and entry for inter-connection of indoor & outdoor units.

## 7. SHAFTS

### (a) Shaft Details:

- (i) **Electrical rising main shaft:** 2.2 x 0.8 m for accommodating normal & essential supply rising mains.
- (ii) **Wet riser shaft:** 1.2 m \* 0.8 m.
- (iii) **Telephone shaft:** 0.6 m \* 0.3 m
- (iv) **Fire alarm shaft:** 0.6 m \* 0.3 m.
- (v) **Computer cabling shaft:** 0.6 m \* 0.3 m.

**Please see Annexure VIII & IX.**

### (b) Door for Shafts:

Door for Wet riser shaft may be provided as per Annexure XI. Provide steel door frame & steel doors with locking arrangement for other shafts. Doors to open towards corridor.

**Please see Annexure XI & Annexure XII.**

**Note:** No wooden doors shall be used since they pose fire risk.

### (c) Location of Shafts:

- (i) **Fire Alarm Shaft:** It shall be located in the lift lobby/common area and preferably can start from fire control room.

- (ii) **Telephone Shaft:** Preferable to start from telephone room.
- (iii) Shaft shall be in common area and not inside any room, so that they are accessible to service personnel even after office hours.
- (iv) Away from water/ drainage shafts. Not to be exposed to rains etc.

## 8. CABLE ENTRY PIPES

Provide For:

- (a) Cable entry into sub-station.
- (b) Sub-station to rising main shafts.
- (c) Cable entry into telephone room.
- (d) Wet riser pump to wet riser shafts.

## 9. S.D.Bs

Shall be recessed in walls nearest to load and niches for the same are not required.

## 10. FALSE CEILING IN CORRIDOR

When services like telephone/ computer/ electrical cables have to be taken in the corridor, it is better to provide false ceiling, so that the service cables are properly covered and don't present a shabby look. Also it helps in laying additional cables in later years.

## 11. FALSE CEILING IN ROOMS

Light fittings, AC diffusers, fire detectors, P.A. speakers will be fixed on false ceiling. Therefore it is necessary to locate all these fixtures to give a symmetrical and aesthetic look. False ceiling materials should be of fire resistance type.

## 12. CHECKLIST

- (a) Electrical sub-station.
- (b) Wet riser pump house.  
Water supply pump house.
- (c) Lift:
  - (i) Number.
  - (ii) Capacity.
  - (iii) Shaft dimensions.
  - (iv) M/c. Room dimensions.
  - (v) Pit depth.
  - (vi) Overhead.
  - (vii) No intrusion of structural members into lift shaft /pitch etc.
  - (viii) Water proofing of lift pit.
- (d) Fire control room and telephone room.

- (e) Shafts:
  - (i) Electrical rising main shaft.
  - (ii) Wet riser shaft.
  - (iii) Telephone shaft.
  - (iv) Fire alarm shaft.
  - (v) Computer cabling.
- (f) Doors for shafts.
- (g) Location of shafts.
- (h) Service-entry pipes.
- (i) Central air-conditioning:
  - (i) AC plant room.
  - (ii) Cooling tower location.
  - (iii) AHU room.
  - (iv) AHU room drainage, fresh air opening.
  - (v) Chiller pipes shaft, chiller pipe entry into building.
  - (vi) False ceiling co-ordination.
  - (vii) Ceiling height to accommodate ducting.
  - (viii) Water requirement.
  - (ix) Routes of piping/cable.
  - (x) Thermal/acoustic insulation.
  - (xi) Airtightness of windows/ doors. It is proper to provide double glazed window panes for insulation.
- (j) Split AC Units:
  - (i) Location of condensing units.
  - (ii) Interconnection of condensing and indoor units finalisation of route.
- (k) Window Type AC Units: Window frames compatible with opening for window type AC units.
- (l) Corridor false ceiling to cover service cables.
- (m) False ceiling to symmetrically provide for AC diffuser, fire detectors, light fittings and P.A. speakers. False ceiling material should be fire resistant.
- (n) Water supply co-ordination: Drinking water, toilet water, horticulture, fire fighting, air-conditioning, assessment of water requirements, location of tanks, O.H. tanks and pumping arrangements.
- (o) Co-ordination of various service pipe/ cable routes: Coordination of water supply, storm water, drain water, sewerage, electricity, telephone, computer, wet riser pipes, air-conditioning cables/ pipes fixing their routes, so that the service/ cable pipes are co-ordinated and various executing agencies don't clash over routes.

## ANNEXURE I

### Electric Sub-Station Cum Fire Pump House (where Sub-station is a Separate Building)

6

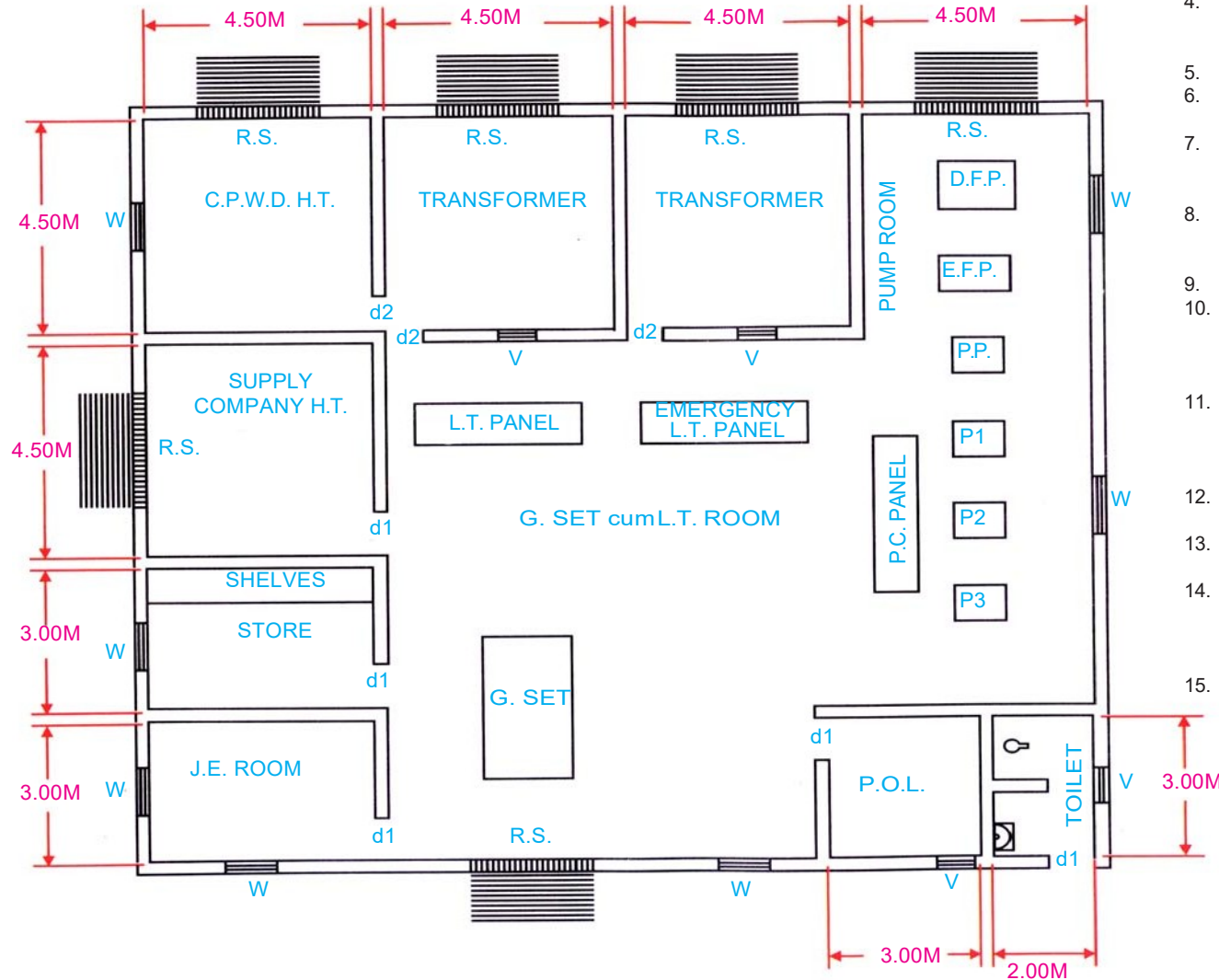

#### NOTE :

1. Floor to ceiling height - 4.5 m  
Floor level - 30 cm above ground level.
2. Motorable concrete approach road all-round.
3. Partition walls - 30 cm thick brick.
4. Heavy-duty steel ladder with side railing upto sub-station roof for roof drainage maintenance.
5. 1 m wide chajja projection all around.
6. Underground water tank as near as possible to pump room.
7. Rolling shutter 2.5 m wide - 3 m height as per Annexure X and with ventilation grills.
8. All doors of steel for fire protection.  
d1 - 1 m wide - 2 m height  
d2 - .75 m wide - 1.8 m height
9. W - window - normal size with grill.
10. V - ventilator. Size 75 cm wide - 50 cm height. made of steel frame with heavy wire mesh. 50 cm below ceiling.
11. D.F.P. - Diesel fire pump.  
E.F.P. - Electrical fire pump.  
P.P. - Jockey pump.  
P1, P2, P3 - Water supply pumps.
12. Cable entry pipes - Executive Eng. will give location and details.
13. Cable trenches - Executive Eng. will give details.
14. Protection boundary wall with gate - if sub-station is a protected premise, suitable boundary walls with gates to be provided.
15. Store shelves - .75 m deep, RCC, 1 m, 2 m, 3 m above ground level.

#### NOTE :

1. Transformer/ HT Panel shall be 'Dry' type when sub-station is housed with main building. (It is not a separate building away from main building).
2. Room with wall enclosure, in case of 'Dry' transformer, is not essential.

## ANNEXURE II

### Electrical Sub-Station Building

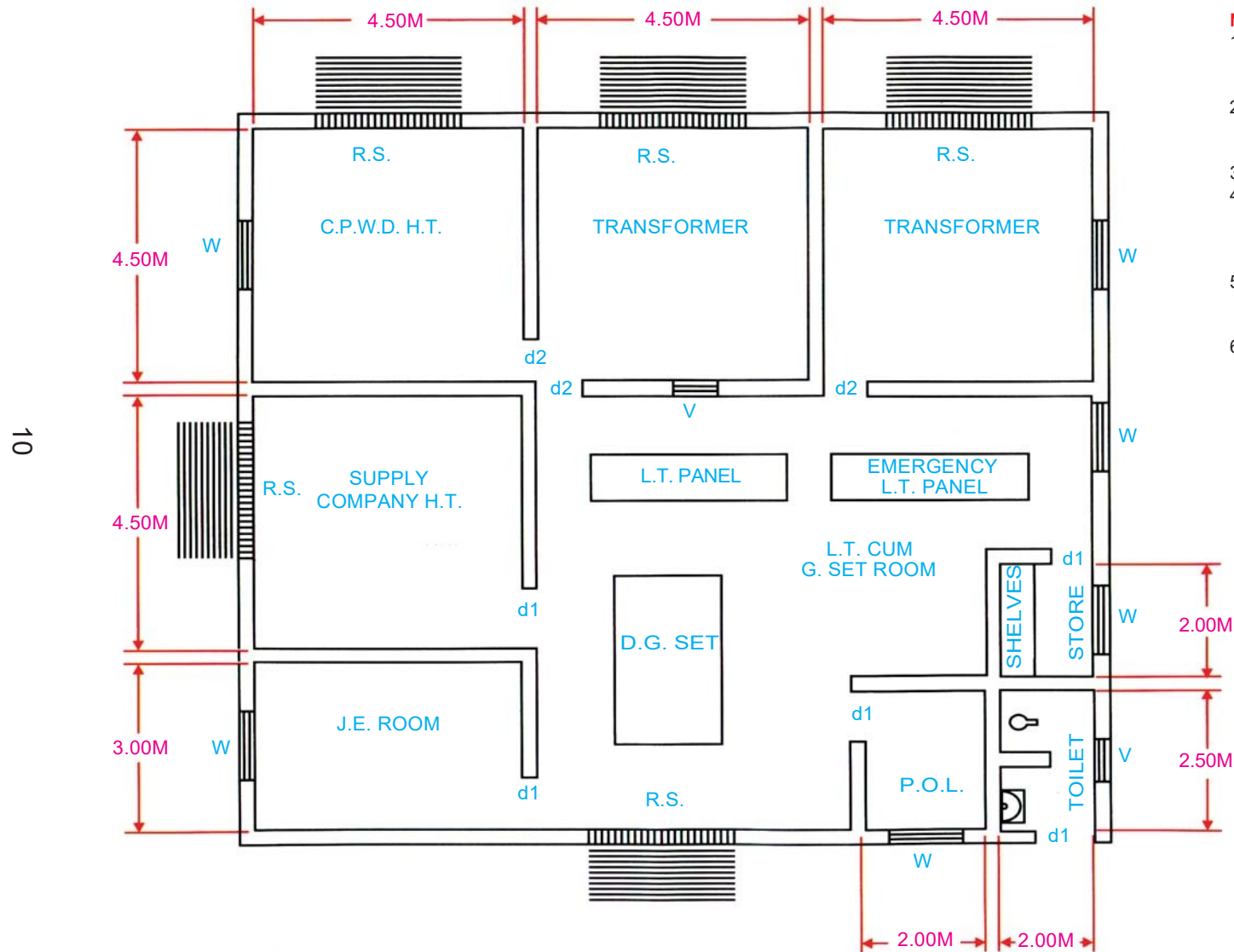

**NOTE :**

1. Rolling shutter 2.5 m wide - 3 m height as per Annexure X and with ventilation grills.
2. All doors of steel for fire protection.  
d1 - 1 m wide - 2 m height  
d2 - .75 m wide - 1.8 m height
3. W - window - normal size with grill.
4. V - ventilator. Size 75 cm wide - 50 cm height made of steel frame with heavy wire mesh 50 cm below ceiling.
5. No toilet is required where sub-station is located in the main building itself.
6. Store shelves - .75 m deep, RCC, 1 m, 2 m, 3 m above ground level.

**NOTE :**

1. Transformer/ HT Panel shall be 'Dry' type when sub-station is housed with main building. (It is not a separate building away from main building).
2. Room with wall enclosure, in case of 'Dry' transformer, is not essential.

## ANNEXURE III

### Typical Layout of D.G. Sets, Sub-Station Equipment and A.C. Plant Room 2\*1000 KVA Transformer 2\*500 KVA D.G. Set 300 TR\*3 A.C. Plant

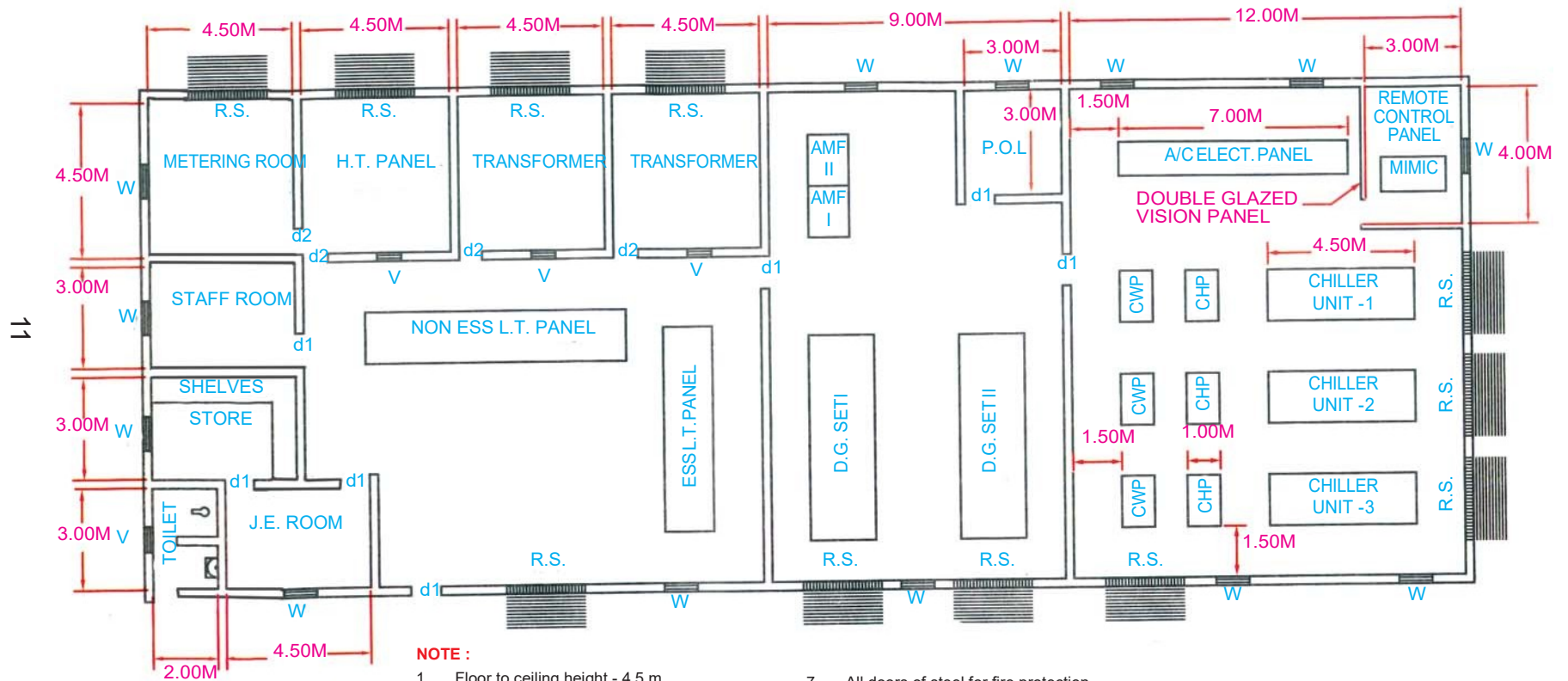

**NOTE :**

1. Decide cooling tower location.
2. Transformer/ HT Panel shall be 'Dry' type when sub-station is housed with main building. (It is not a separate building away from main building). Room with sally enclosure.

**NOTE :**

1. Floor to ceiling height - 4.5 m  
Floor level - 30 cm above ground level.
2. Motorable concrete approach road all-round.
3. Partition walls - 30 cm thick brick.
4. Heavy-duty steel ladder with side railing upto sub-station roof for roof drainage maintenance.
5. 1 m wide chajja projection all around.
6. Rolling shutter 2.5 m wide - 3 m height as per Annexure X and with ventilation grills.
7. All doors of steel for fire protection.  
d1 - 1 m wide - 2 m height  
d2 - .75 m wide - 1.8 m height
8. W - window - normal size with grill.
9. V - ventilator - Size 75 cm wide - 50 cm height. made of steel frame with heavy wire mesh. 50 cm below ceiling.
10. C.H.P. - Chiller water pump  
C.W.P. - Condenser water pump  
A.M.F. - Automatic main failure panel.
11. Cable entry pipes - Executive Eng. will give location and details.
12. Cable trenches - Executive Eng. will give details.
13. Protection boundary wall with gate - if sub-station is a protected premise, suitable boundary walls with gates to be provided.
14. Store shelves - .75 m deep, RCC, 1 m, 2 m, 3 m above ground level.

## ANNEXURE IV

### Under Ground Wet Riser Pump Room for Positive Suction

12

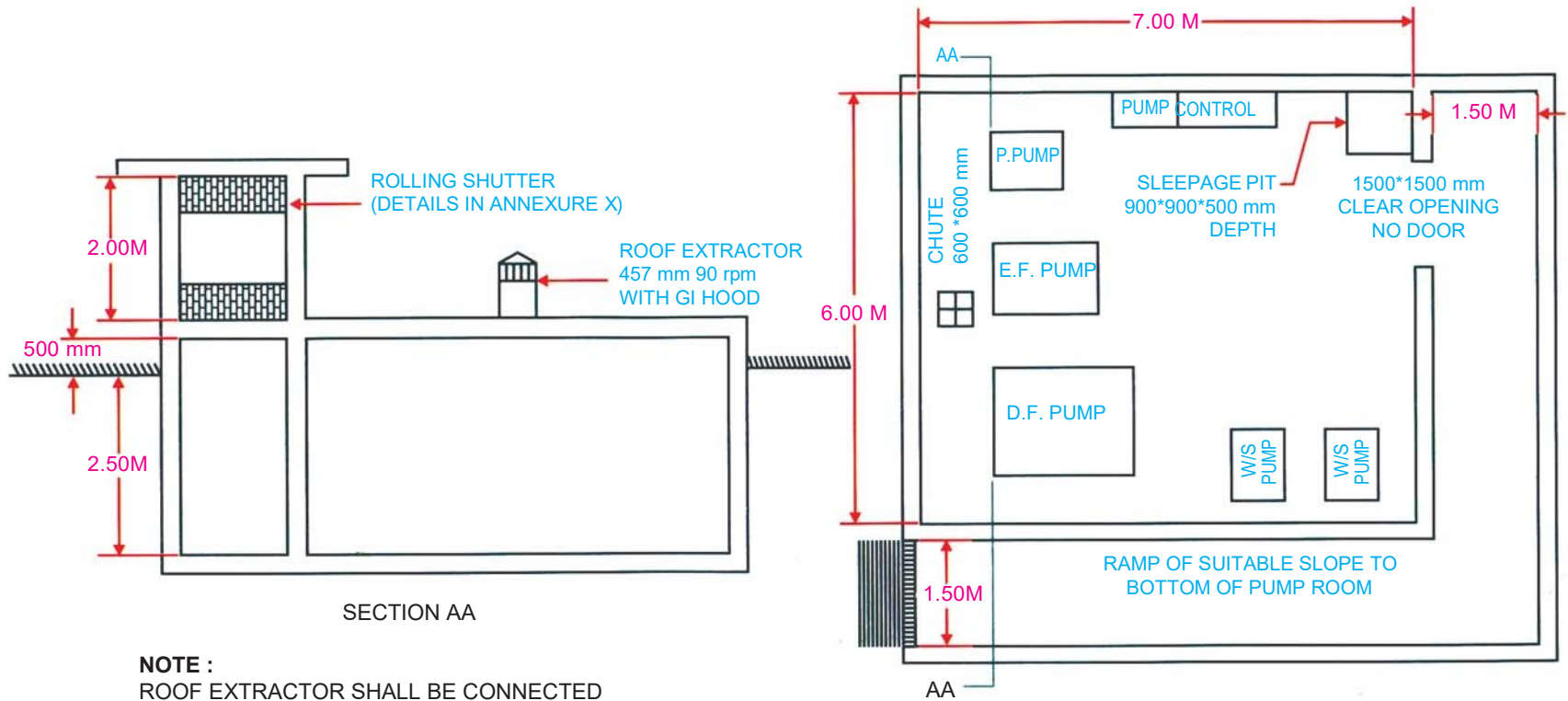

**NOTE :**  
ROOF EXTRACTOR SHALL BE CONNECTED  
TO FIRE PUMP CONTROL FOR AUTOMATIC  
OPERATION WHEN THE FIRE PUMP STARTS

## ANNEXURE V

### Pump Room for Wet Riser Cum Water Supply

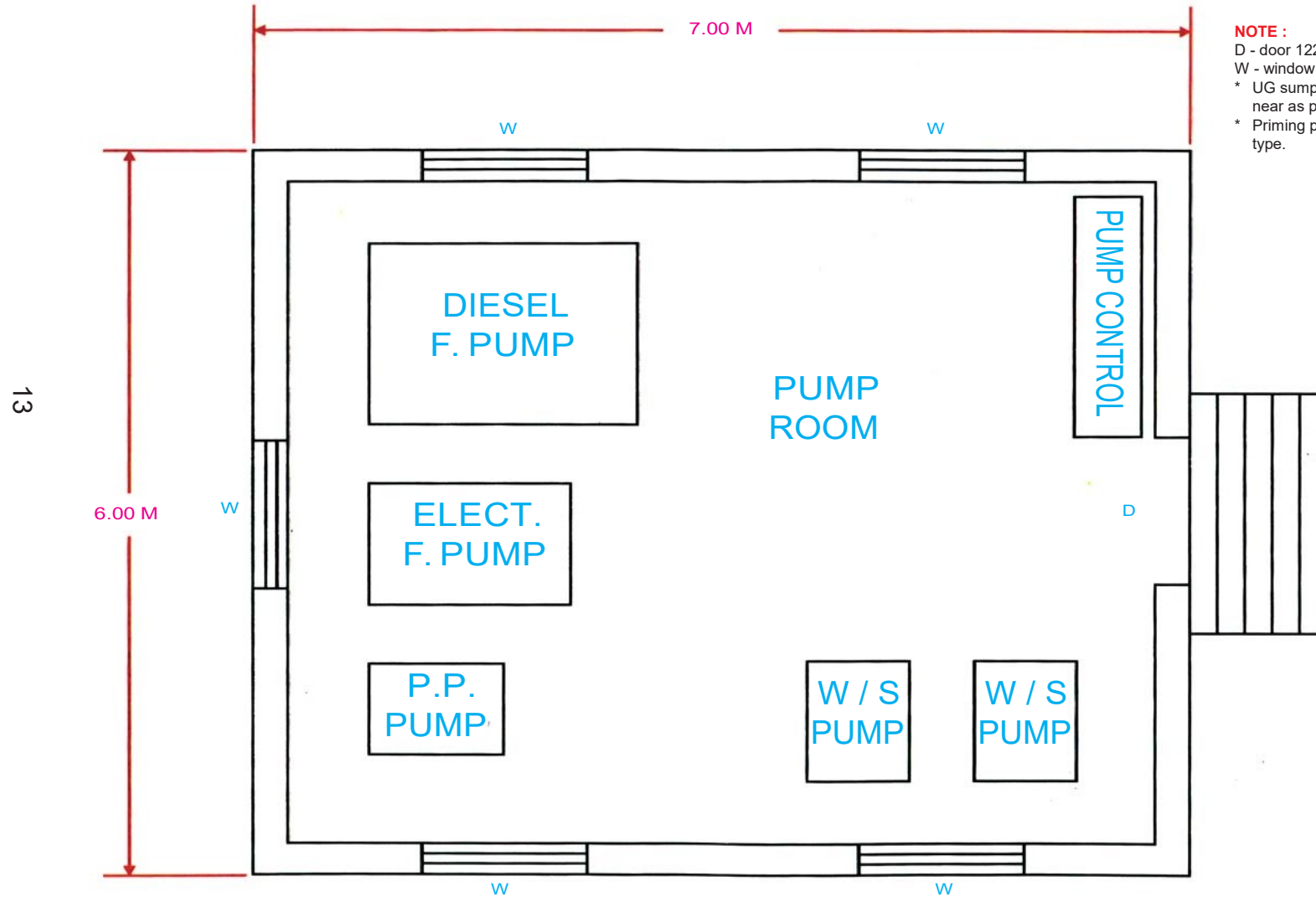

#### NOTE :

D - door 1220 \* 2000 mm with double leaf.  
W - window suitable size.

\* UG sump and pump room should be as near as possible.

\* Priming pump should be submersible type.

## ANNEXURE VI

### Typical Arrangement for Providing Combined Fire Fighting and Domestic Water Storage Tank Part IV : Fire Protection National Building Code

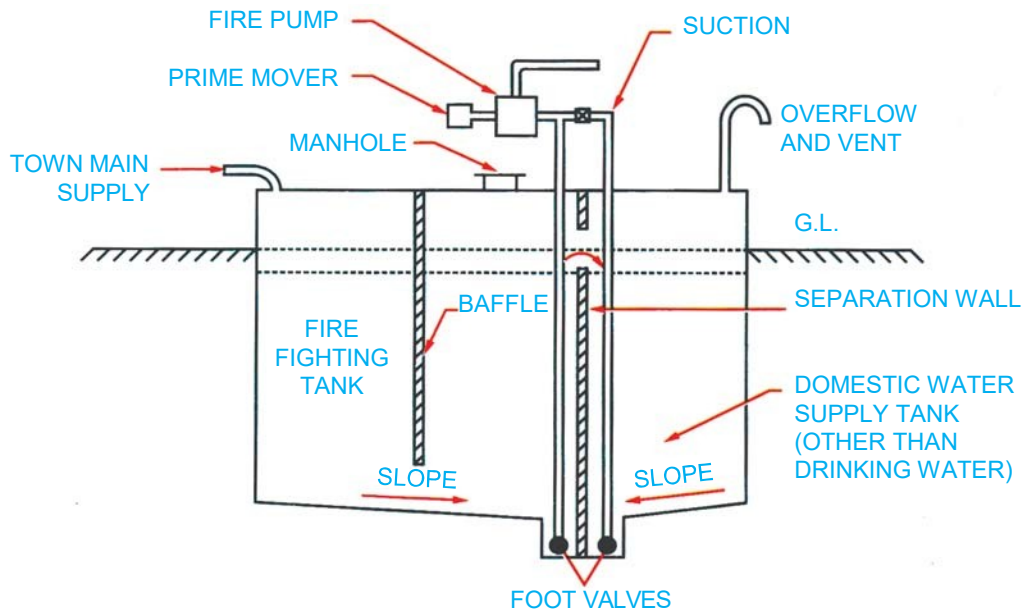

3A WITH NEGATIVE SUCTION

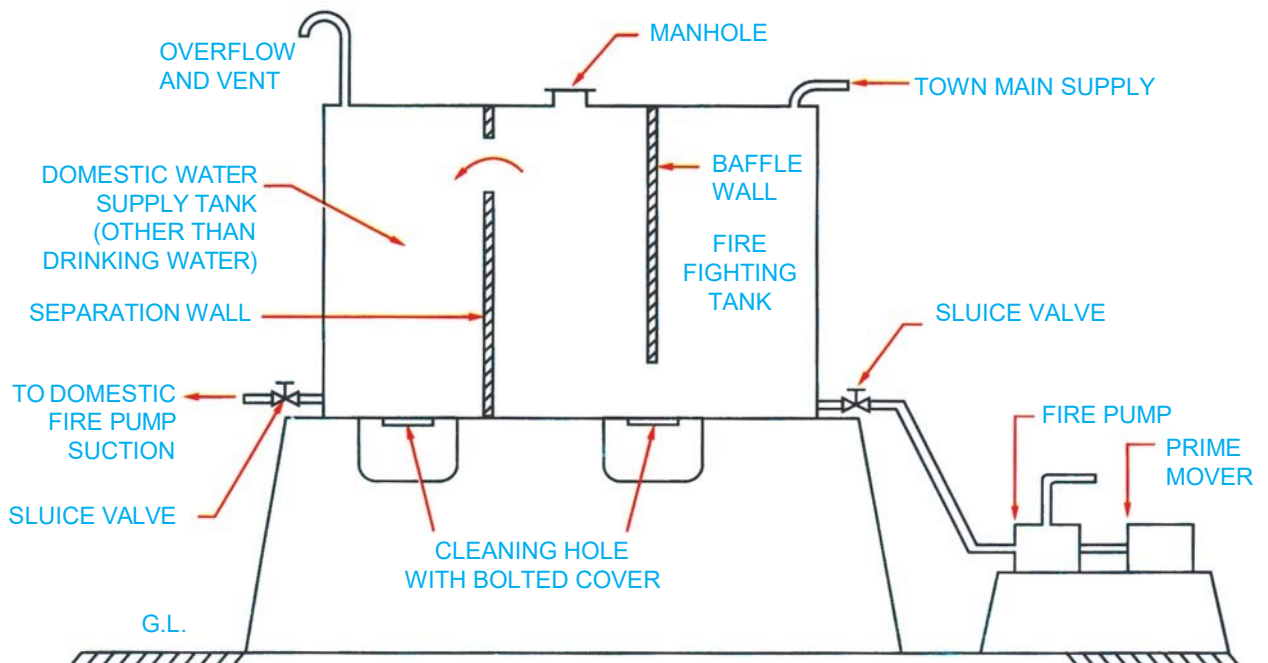

3B WITH POSITIVE SUCTION

## ANNEXURE VII-A

### Recommended Dimensions of Passenger Lifts

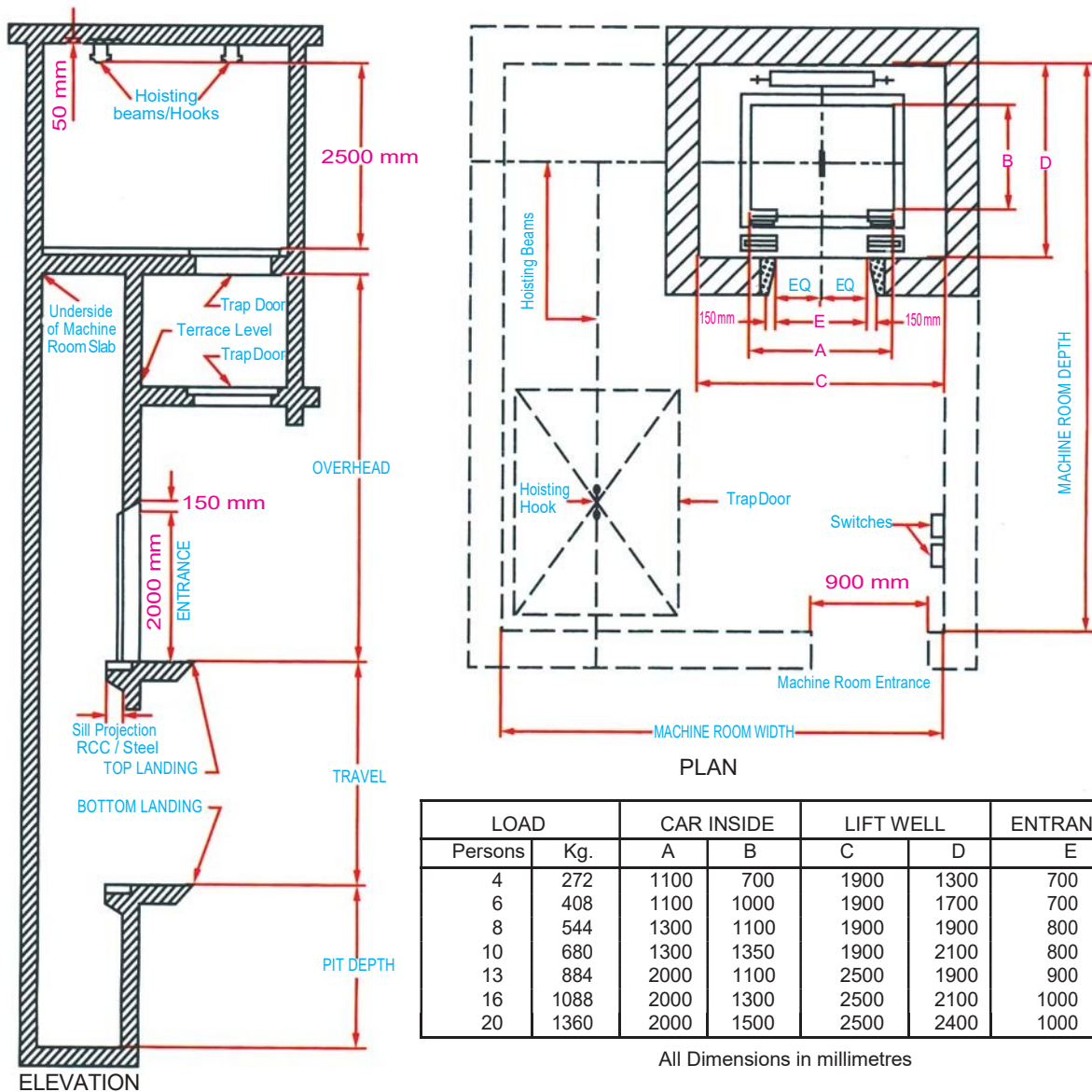

Recommended dimension for Pit, Overhead and Machine Room for Passenger Lifts

SPEED IN M/S	Upto .70	>.7 <= 1	>1 <= 1.5	>1.5 <= 1.75	>1.75 <= 2	>2 <= 2.5
PIT DEPTH	1350	1500	1600	2150	2200	2500
OVERHEAD	4200	4250	4800	4800	5200	5400
MACHINE ROOM DEPTH	D+2000			D+2500		
MACHINE ROOM WIDTH	C+1000		C+1200		C+1500	

All Dimensions in millimetres

**Note:**

1. The total headroom has been calculated on the basis of car height of 2.3 m.
2. In the case of manually operated doors, clear entrance will be reduced by the amount of projection of the landing door.
3. All dimensions given above for lifts having centre opening power operated doors with counterweight at rear, are recommended dimensions primarily for architects and building planners. Any variations mutually agreed between manufacturer and purchaser are permitted. However, variation in :
  - (i) Car inside dimension shall be within the maximum area limits specified in 5 of IS 14665 (Part 3/Sec. 1).
  - (ii) Entrance width on higher side is permitted.
  - (iii) Entrance width on lower side is permitted upto 100 mm subject to minimum of 700 mm.
4. Dimensions of pit depth and overhead may differ in practice as per individual manufacturer design depending upon load, speed and drive. However, the pit depth and overhead shall be such as to conform to the requirements of bottom clearance and top clearance of IS 14665 (Part 2/Sec. 1).

## ANNEXURE VII-B

### Recommended Dimensions of Goods Lifts (For Speed upto 1.5 m/s)

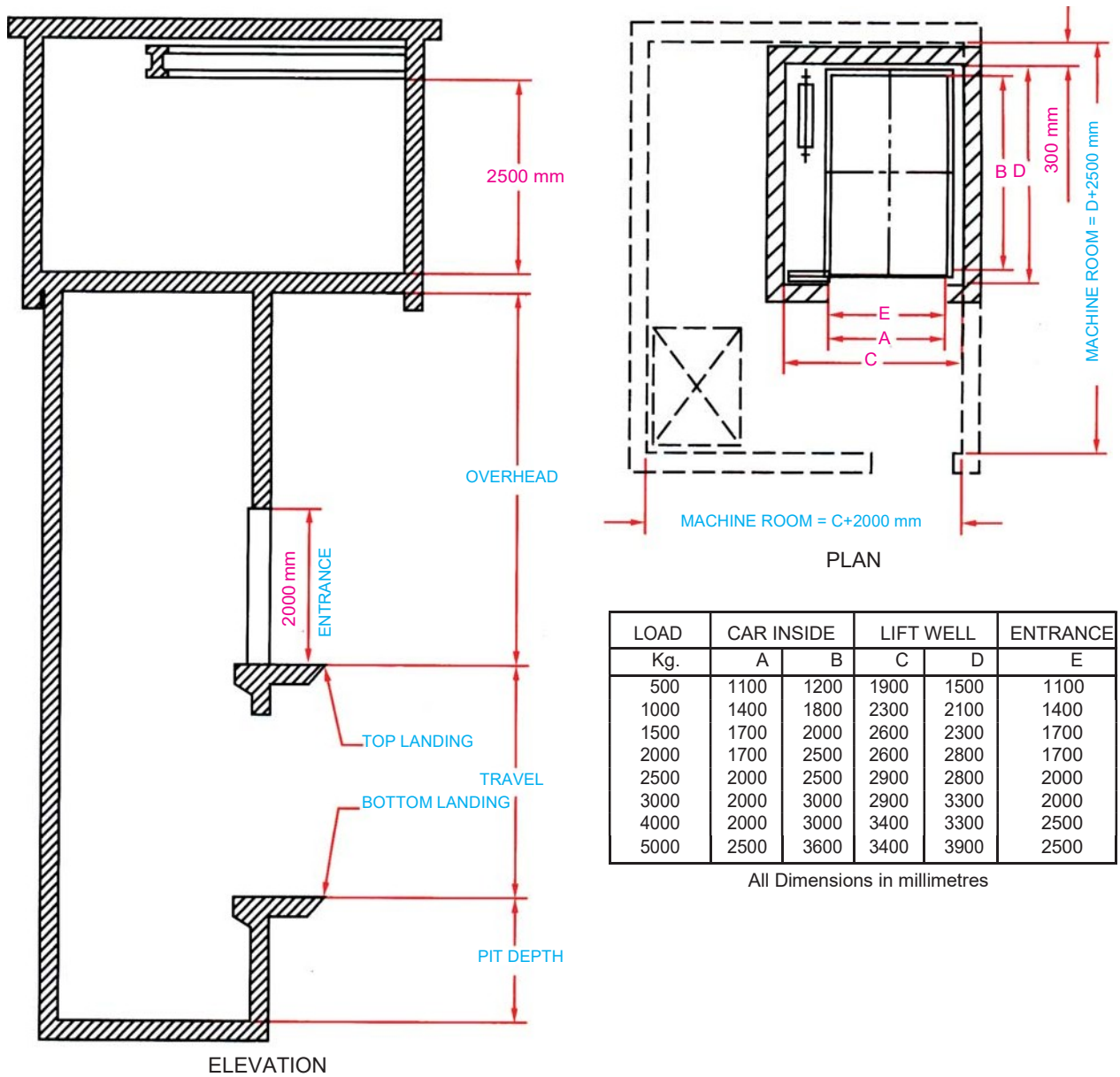

**Note:**

1. The width of the machine room shall be equal to the lift well width 'C' subject to minimum of 2500 mm.
2. The total headroom has been calculated on the basis of car height of 2.2 m.
3. Clear entrance width 'E' is based on vertical lifting car door and vertical biparting landing doors. For collapsible mid-bar doors the clear entrance width will be reduced by 200 mm (maximum 1800 mm)
4. All dimensions given above are recommended dimensions primarily for architects and building planners. Any variations mutually agreed between manufacturers and purchaser are permitted. However, variation in car inside dimensions shall be within the maximum areas limits specified in IS 14665 (Part 3/Sec. 1).
5. Dimensions of pit depth and overhead may differ in practice as per individual manufacturer design depending upon load, speed and drive. However, the pit depth and overhead shall be such as to conform to the requirements of bottom clearance and top clearance of IS 14665 (Part 2/Sec. 1).

## ANNEXURE VII-C

### Recommended Dimensions of Hospital Lifts (For Speed upto 1.5 m/s)

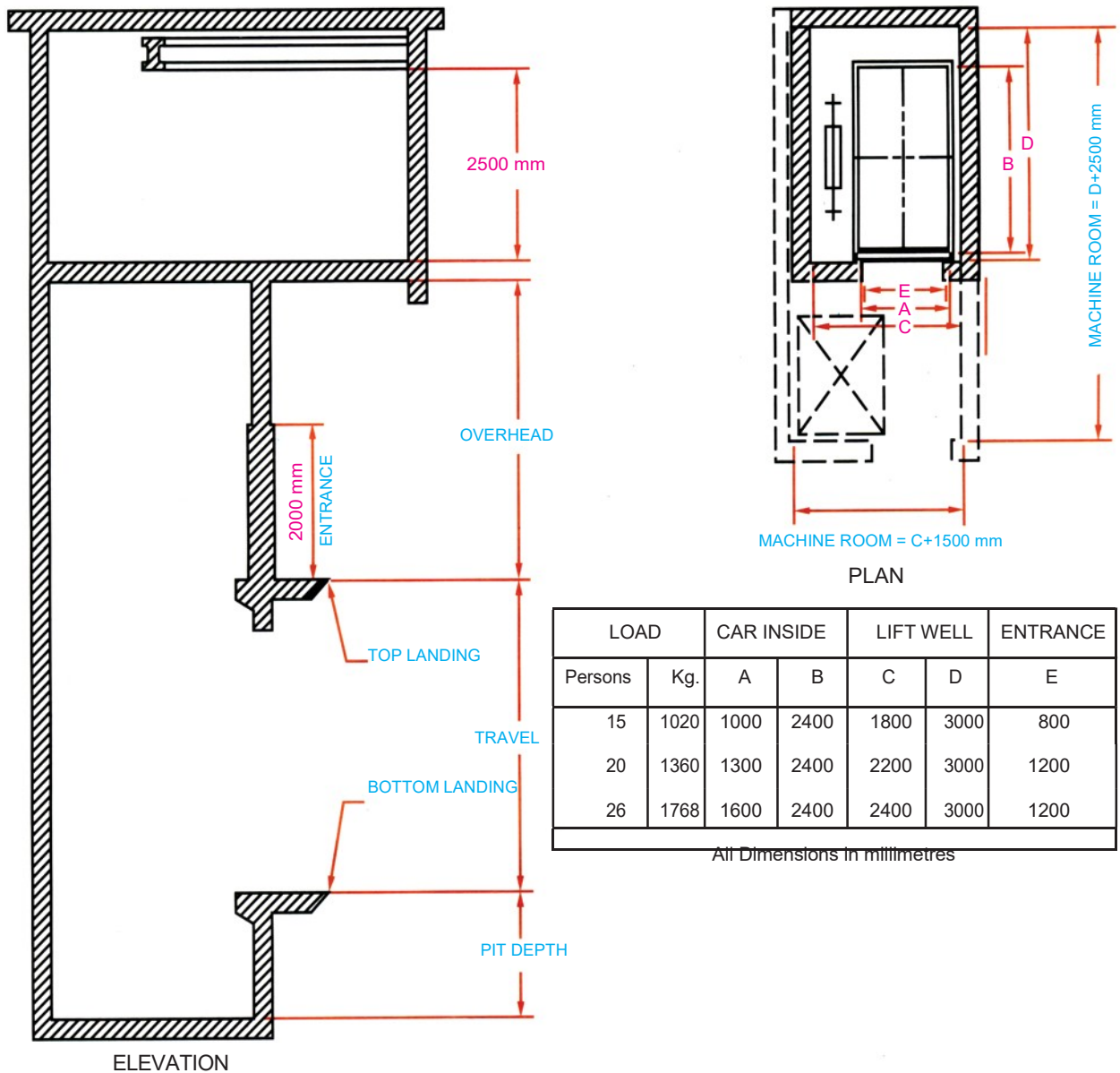

**Note:**

1. The total headroom has been calculated on the basis of car height of 2.2 m.
2. In the case of manually operated doors, clear entrance will be reduced by the amount of projection of the landing door.
3. Although 15 persons capacity lift is not standard one, this is included to cover lifts of smaller capacity which can be used in hospitals.
4. All dimensions given above are recommended dimensions primarily for architects and building planners. Any variations mutually agreed between manufacturer and purchaser are permitted. However, variation in car inside dimensions shall be within the maximum area limits specified in IS 14665 (Part 3/Sec. 1).
5. Dimensions of pit depth and overhead may differ in practice as per individual manufacturer design depending upon load, speed and drive. However, the pit depth and overhead shall be such as to conform to the requirements of bottom clearance and top clearance of IS 14665 (Part 2/ Sec. 1).

## ANNEXURE VII-D

### Recommended Dimensions of Service Lifts (For Speed upto 0.5 m/s)

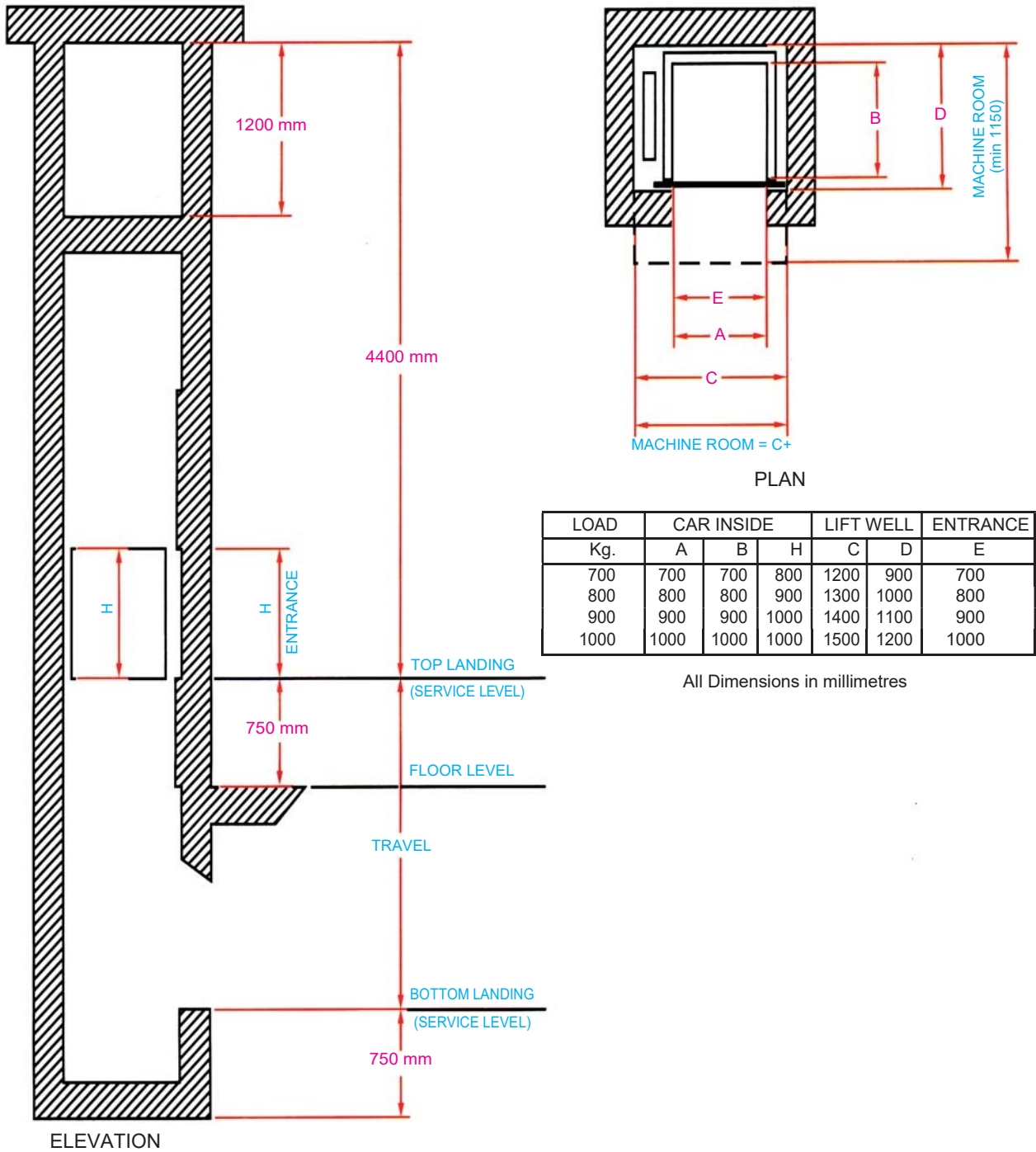

**Note:**

Entrance width 'E' is based on assumption of provision of vertical biparting doors (no car door is normally provided).

## ANNEXURE VIII

### Electrical Rising Main and Wet Riser Shaft

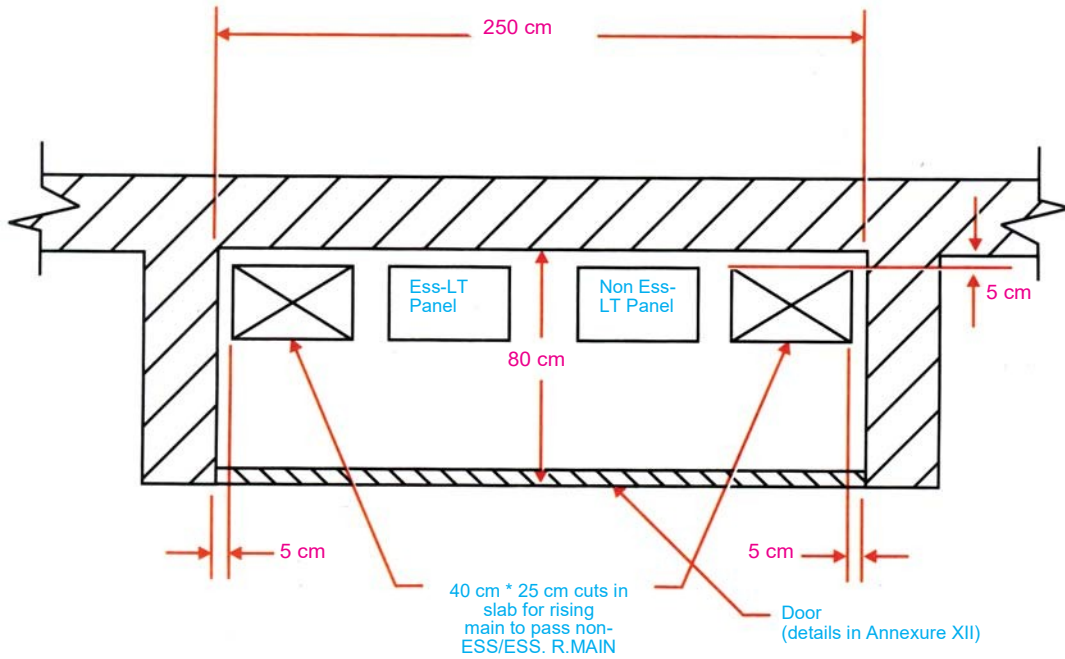

### ELECTRICAL RISING MAIN SHAFT

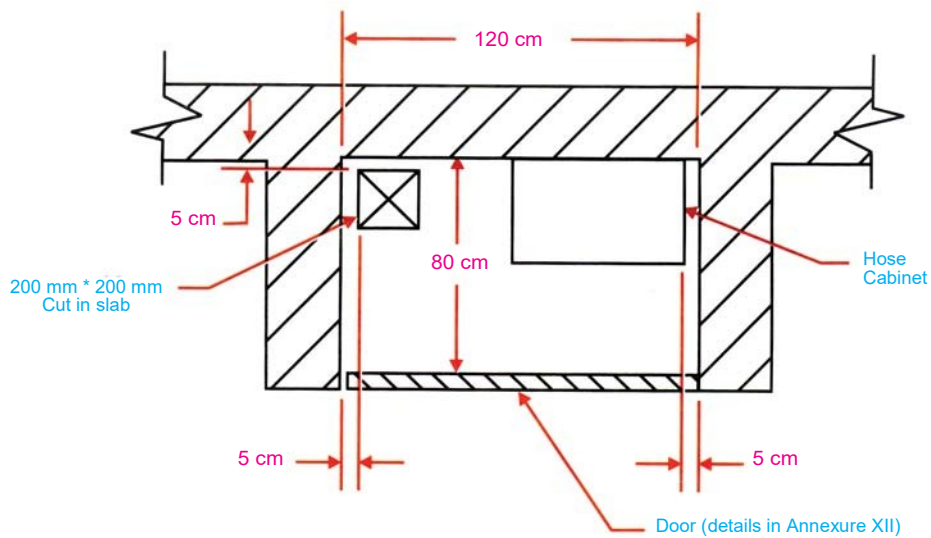

### WET RISER SHAFT one for 1000 sq.mtrs Floor Area

# ANNEXURE IX

## Telephone & Fire Control Room

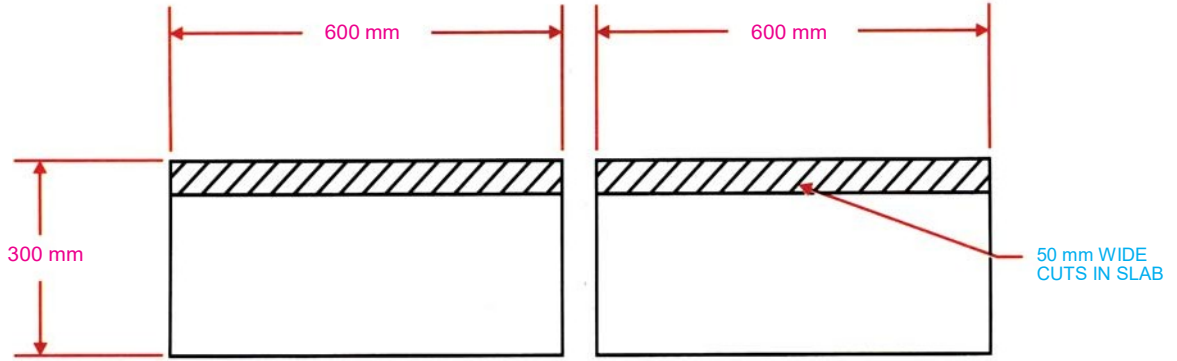

FIRE ALARM SHAFT  
DETAILS

TELEPHONE SHAFT  
DETAILS

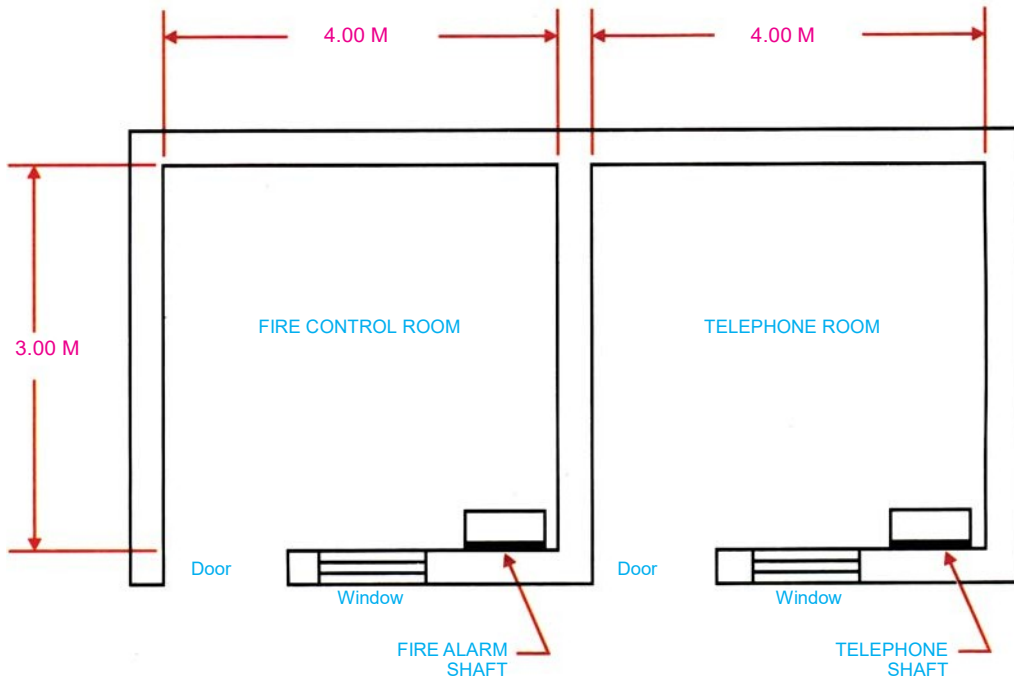

# ANNEXURE X

## Rolling Shutter for Sub-Station

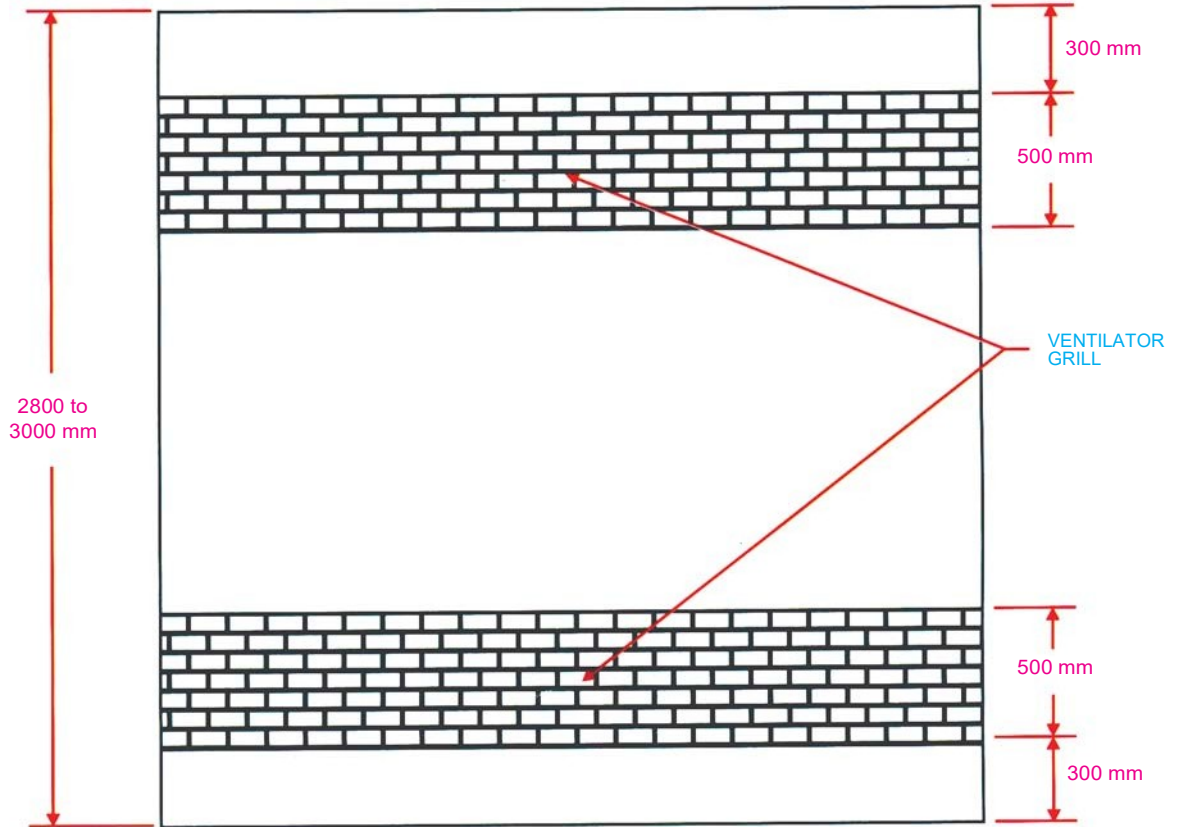

## ANNEXURE XI

### Wet Riser Shaft Door Details

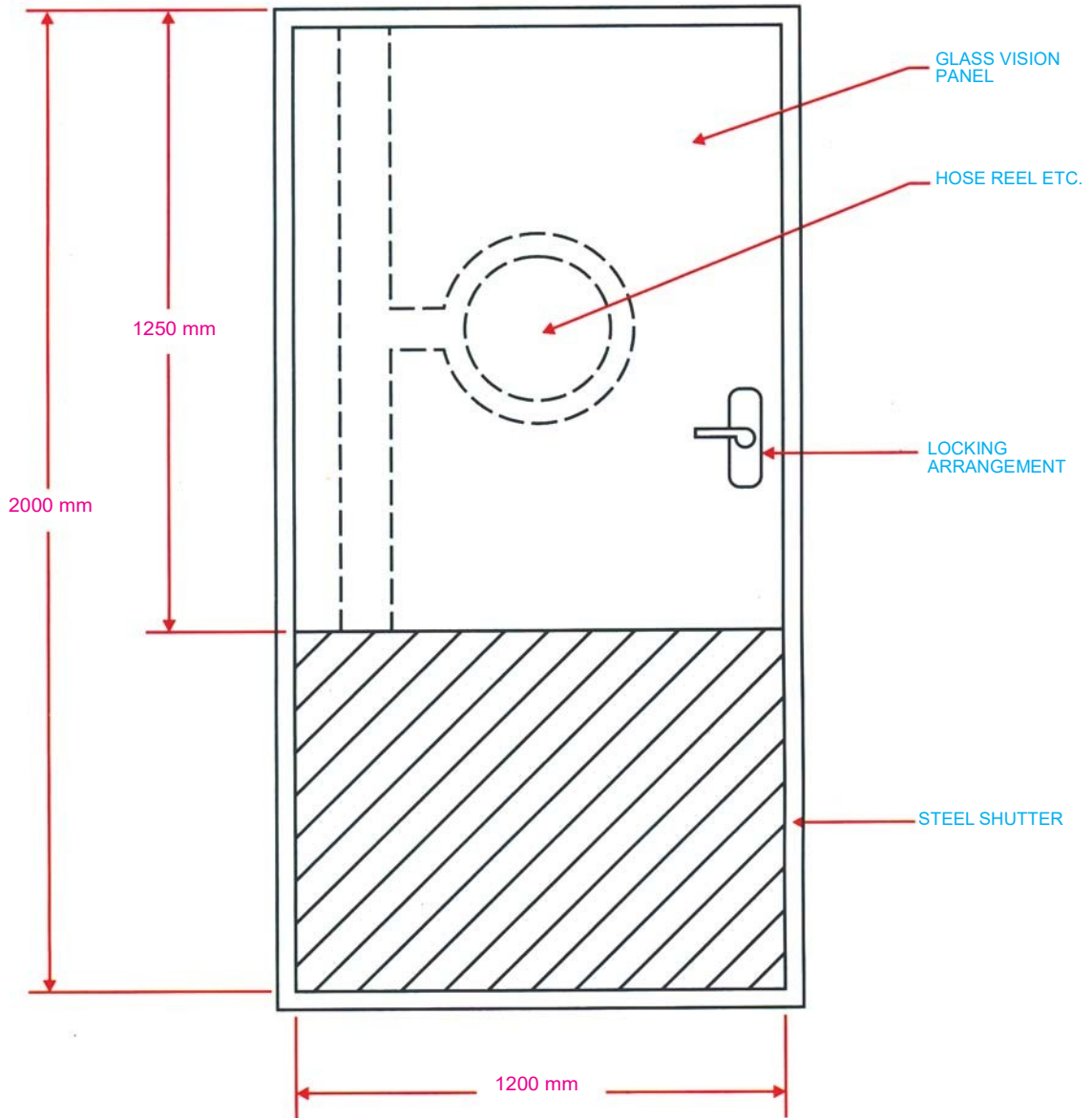

## ANNEXURE XII

### Electrical Shaft Door and Telephone Fire Alarm Shaft Door

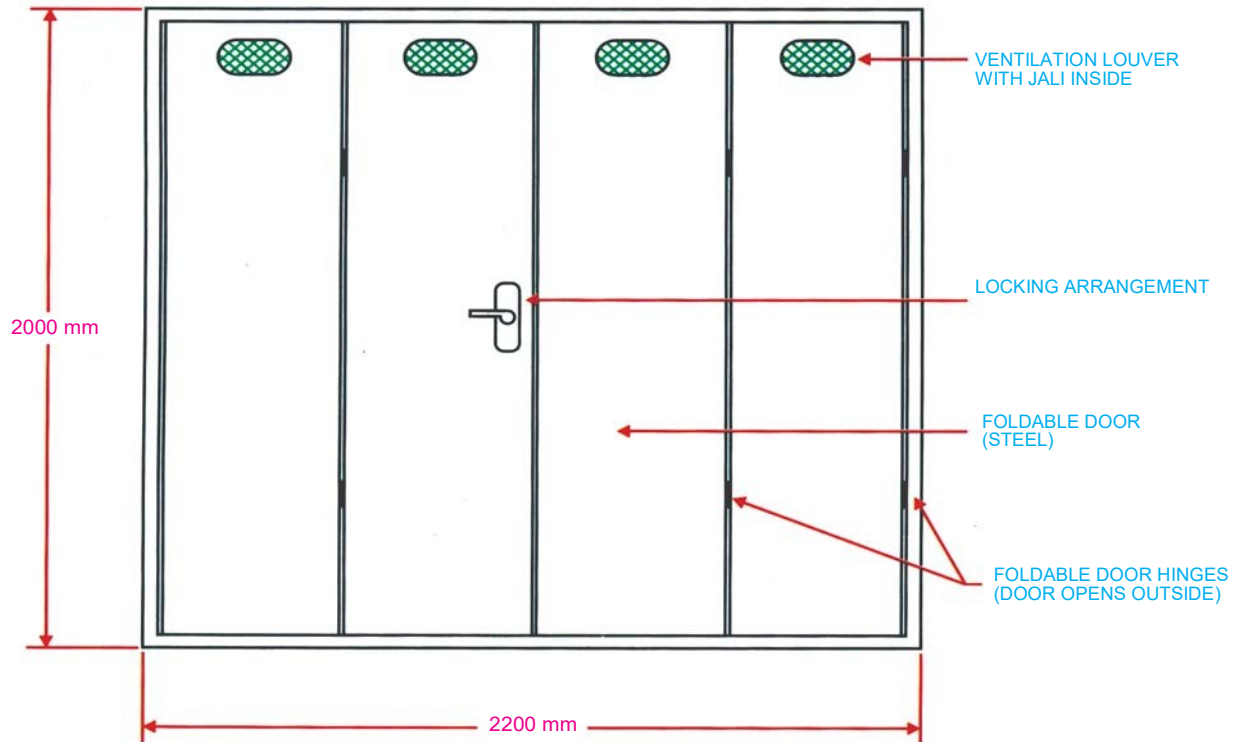

**ELECTRICAL SHAFT DOOR DETAILS**

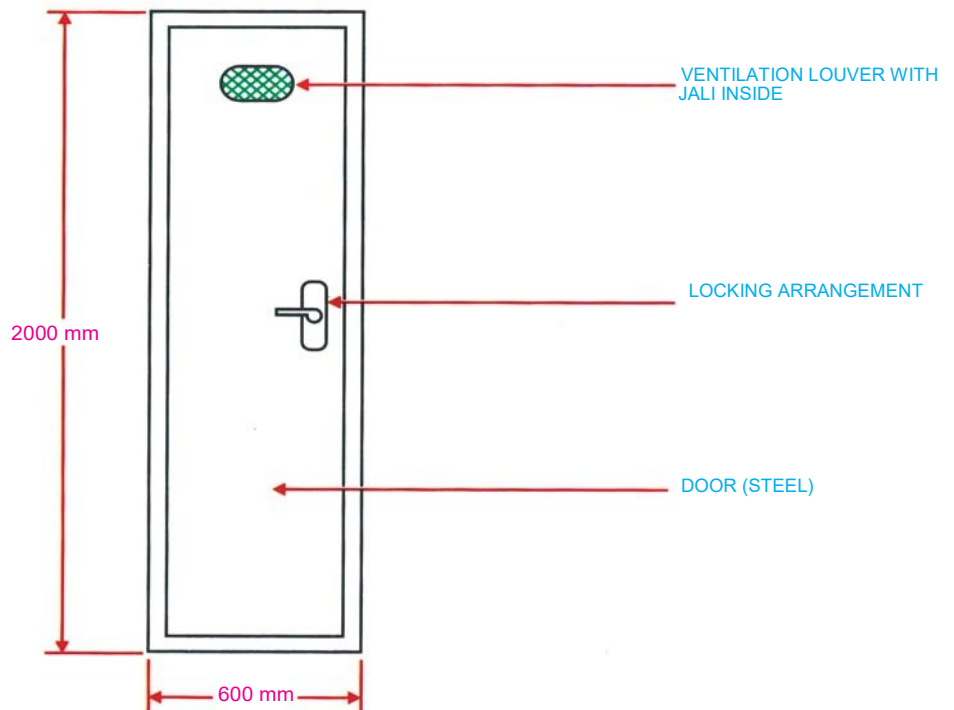

**TELEPHONE / FIRE ALARM SHAFT DOOR DETAILS**

**ANNEXURE XIII**

**Window and Ventilator Design**

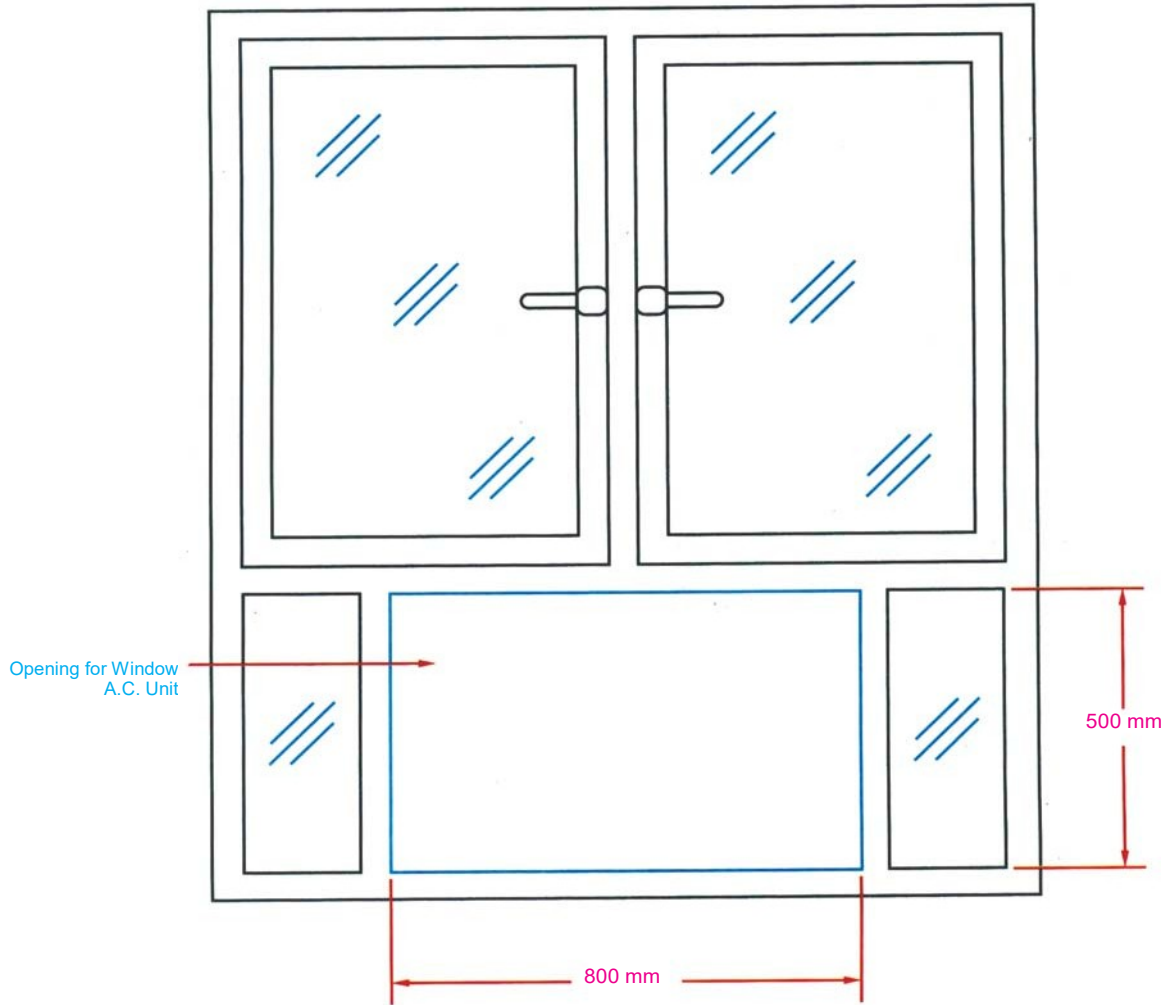

**WINDOW DESIGN COMPATIBLE WITH INSTALLATION OF WINDOW AC UNIT**

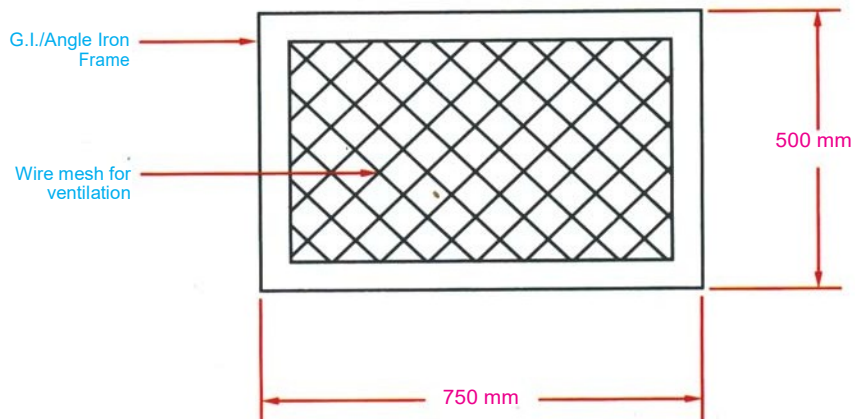

**VENTILATOR DESIGN**

## ANNEXURE XIV

### Structural Details for Air-conditioning Plants in Office Buildings

(For Preliminary Drawing/Design only)

<b>A</b>	<i>Capacity of AC Plant (in MS office Building)</i>	
	Basement	90 Cu Meter/ton
	Ground Floor	75 Cu Meter/ton
	Intermediate Floors	70 Cu Meter/ton
	Top Floor	60 Cu Meter/ton

<b>B</b>	<i>Central Plant</i>	
	(i) Size of central plant room including weather maker	10 sqm + 0.8 sqm per ton (Clear height not less than 3.75 m below soffit of beam)
	(ii) Size of central plant room excluding weather maker	5 sqm + 0.5 sqm per ton
	(iii) Size of weather maker room	5 sqm + 0.3 sqm per ton (Clear height not less than 3 m below soffit of beam) (above 150 tons : 0.5 sqm per ton)
	(iv) Fresh Air opening in weather maker room	0.03 sqm per ton
	(v) (a) Main supply and return duct (Taken together)	0.10 sqm per ton
	(b) Supply grills (height 20 cm to 25 cm)	0.10 sqm per ton
	(c) Return grills (height 20 cm to 25 cm)	0.12 sqm per ton
	(vi) (a) Cooling tower : natural draft	0.40 sqm per ton
	(b) Cooling tower : induced draft	0.15 sqm per ton
	(vii) Cooling pond (depth 1.5 m)	1.0 sqm per ton
	(viii) Water consumption	20 litre per tone per hour
	(ix) Make up water tank	12 hrs./ 8 hrs. storage capacity for 24 hrs./ 12 hrs. operation respectively. Bottom level shall be 2 m above the cooling tower sump.

<i>C</i>	<i>Window type units</i>	
	Size of the opening in wall	80 cm wide * 50 cm high (see annexure XIII)

<i>D</i>	<i>E.T.A.C. Plant</i>	
	(i) Plant room	20 sqm + 0.6 sqm for every 100 cum of space to be cooled
	(ii) Fresh air shaft	0.25 sqm for 100 cum of space to be cooled
	(iii) Duct (masonry)	0.05 sqm for 100 cum of space to be cooled
	(iv) Duct (Metal)	0.10 sqm for 100 cum of space to be cooled

<i>E</i>	<i>Floor Loading (Assumed Uniformly Distributed Over Entire Area of the Room)</i>	
	1. Plant room (central)	3000 kg / sqm
	2. Plant room for package type unit (excluding pump sets & weather maker room)	1200 kg / sqm
	3. Pump room & weather maker room	1200 kg / sqm
	4. Cooling tower	
	(a) Natural draft	300 kg / ton
	(b) Masonry shell induced draft cooling tower (usually above 100 ton)	400 kg / ton
	(c) Wooden package wooden shell/ FRP type induced type cooling tower (usually above 100 tons)	100 kg / ton

**ANNEXURE XV**

**Water Requirement for Fire Protection with Wet Riser/Down Corner System**

**As per N.B. Code**

**TABLE 4**

<b>Residential Buildings</b>		
	<i>U.G. Water Storage Tank Static</i>	<i>Terrace Tank</i>
Above 15 m upto 30 m	50,000 lts	10,000 lts
Above 30 m upto 45 m	1,00,000 lts	20,000 lts
Above 45 m	2,00,000 lts	40,000 lts

**TABLE 5**

<b>Business Building</b>		
	<i>U.G. Water Storage Tank Static</i>	<i>Terrace Tank</i>
Above 15 m upto 30 m	1,00,000 lts (50,000 lts if covered area in G.F. is less than 300 sq. m.)	20,000 lts
Above 30 m upto 45 m	2,00,000 lts	20,000 lts
Above 45 m	2,50,000 lts	50,000 lts

## ANNEXURE XVI

### 12 minimum Fire Safety Measures as per National Building Code

1.	Means of access
2.	Underground / overhead water static tanks
3.	Automatic Sprinklers system
4.	First-aid Hose Reels
5.	Fire extinguishers of ISI certification marks
6.	Compartmentation
7.	Automatic fire detection and alarm system/ manually operated electrical fire alarm system
8.	Public address system
9.	Illuminated exit way marking signs
10.	Alternate source of electric supply
11.	Fire lift with fireman switch
12.	Wet rise/down corner system.