



सत्यमेव जयते



Guidelines for SUBSTATION & POWER DISTRIBUTION SYSTEMS of Buildings

2019



CENTRAL PUBLIC WORKS DEPARTMENT
Ministry of Housing and Urban Affairs

Guidelines for
SUBSTATION &
POWER DISTRIBUTION SYSTEMS
of Buildings

2019



CENTRAL PUBLIC WORKS DEPARTMENT
Ministry of Housing and Urban Affairs

All rights reserved. No part of this publication may be reproduced in any form or by any means, electronic or mechanical, including photocopy, recording or any information storage and retrieval system, without permission, in writing, from the Director General, CPWD, New Delhi.

Developed by the committee consisting of following members

- | | |
|---|--------|
| 1. Shri Vikas Gupta, CE (PEWZ) | Member |
| 2. Shri Vimal Kumar, CE (NDZ-II) | Member |
| 3. Shri Ramesh Kumar Garg, CPM | Member |
| 4. Shri S.S. Garg, SE (E), Vigilance Cell | Member |
| 5. Shri N.K. Bansal, SE (E), CCEC | Member |
| 6. Shri Gaurav Yadav, EE(E), PHEWD | Member |
| 7. Shri J.K. Choudhury, Retd. CE (E) | Member |

GOVERNMENT OF INDIA PUBLICATION

Published Under the Authority of
Directorate General
Central Public Works Department
Nirman Bhawan, New Delhi - 110011



Prabhakar Singh
Director General



भारत सरकार
Government of India



केन्द्रीय लोक निर्माण विभाग
निर्माण भवन, नई दिल्ली-110011
Central Public Works Department
Nirman Bhawan, New Delhi-110011
Tel : 23062556/1317, Fax : 23061884
E-mail : cpwd_dgw@nic.in

FOREWORD

CPWD is the Principal Technical Advisor to Government of India and has been handling all types of Sub-Station and power distribution works in buildings from system design to installation, commissioning, operation & maintenance in Government buildings based on details available in CPWD General Specifications for Sub-Stations and Internal E/I Works. These details brings out some part of planning of Sub-station, hence there was a need for exhaustive planning and design guidelines. As such this publication has been prepared incorporating the latest development & technology which include guidelines for Sub Stations, DG Sets, UPS system, Solar generation, Schematic Diagrams etc. The extracts from National Building Code 2016 are also included in it.

In bringing out these guidelines, I appreciate the sincere efforts put forth by Shri Vikas Gupta, CE (PEWZ), Shri Vimal Kumar, CE (NDZ-II), Shri Ramesh Kumar Garg, CPM, Shri S.S. Garg, SE (E), Vigilance Cell, Shri N.K. Bansal, SE (E), CCEC, Shri Gaurav Yadav, EE (E), PHEWD, Shri J.K. Choudhury, Retired Chief Engineer (E) who were members of the committee constituted by SDG(DR) for putting their untiring efforts in preparing the draft of these guidelines. I also acknowledge the contribution of Dr. K.M. Soni, ADG (TD), Sh. C.K. Varma, CE(E) CSQ and Sh. D.K. Tulani, SE(E) TAS for giving their inputs and bringing out this publication.

I am sure that these guidelines will be useful to all concerned Engineers of CPWD and also to many other Engineering organizations of Central/ State Governments as well as practicing Architects and E&M Consultants.

(PRABHAKAR SINGH)
DIRECTOR GENERAL, CPWD

New Delhi
March, 2019



भारत सरकार

Government of India
अपर महानिदेशक (प्रौ. वि.)

Additional Director General (TD)

केन्द्रीय लोक निर्माण विभाग

Central Public Works Department

प्रथम तल, कमरा संख्या-118, ए-विंग, निर्माण भवन, नई दिल्ली -110011

First Floor, Room No. 118, A Wing, Nirman Bhawan
New Delhi-110011, Phone: 23063389, Fax : 23061068

F-mail : adgtd@nic.in



डॉ. के. एम. सोनी
DR. KRISHNA MURARI SONI



PREFACE

“CPWD Guidelines for Substation and Power Distribution System of Buildings 2019” has been brought out as there was a growing need to prepare these guidelines due to technological changes over a period of time.

In addition to the planning and design concepts, a number of schematic diagrams and single line diagrams have also been included in it.

I express my deep appreciation to Shri Vikas Gupta, CE (PEWZ), Shri Vimal Kumar, CE (NDZ-II), Shri Ramesh Kumar Garg, CPM, Shri S.S. Garg, SE (E), Vigilance Cell, Shri N.K. Bansal, SE (E), CCEC, Shri Gaurav Yadav, EE (E), PHEWD, Shri J.K. Choudhury, Retired Chief Engineer (E) in drafting these guidelines. I also appreciate the efforts of Shri C.K.Varma, Chief Engineer, CSQ (E) and Shri D.K. Tulani, SE (E) TAS for providing valuable inputs and making the entire exercise of the publication possible within the given time frame.

I also acknowledge the efforts put in by Shri. V.K. Khetan, EE (E) TAS and Shri Rajiv Gupta, EE (E) TLQA in this publication.

Errors, omissions and suggestions for improvement, if any, may be brought to the notice of SE (E) TAS, Office of CE CSQ (E), CPWD, Nirman Bhawan, New Delhi.

(Dr. K. M. Soni)

Addl. Director General (TD)

Place: New Delhi
March, 2019



भारत सरकार

Government of India
कार्यालय मुख्य अभियंता सी.एस.क्यू. (वै)
Chief Engineer, CSQ (E)
के.लो.नि.वि.



Central Public Works Department

सी. के. वर्मा
C. K. VARMA

कक्ष संख्या-229, ए विंग, निर्माण भवन, नई दिल्ली -110011
Second Floor, Room No. 229, A Wing, Nirman Bhawan
New Delhi-110011, Phone: 23061418, Fax : 23061418
फोन नं.-011-23062120 फैक्स नं. 23061418

ABOUT THE BOOK

“CPWD Guidelines for Substation and Power Distribution System of Buildings 2019” has been framed keeping in view its need for Engineers of CPWD and also to many other Engineering organizations of Central/State Governments as well as practicing Architects and E&M Consultants.

It enables its readers to assess electrical load of a building and thus enabling to find out the required capacity of the switch gears, transformers etc. It deals with 33 kV/11 kV, 33 kV/0.433 kV & 11 kV/0.433 kV Substations and includes HT panels, Transformers, Bus ducting, LT panels (Essential & Non-essential), APFC panels, SCADA panels, DG sets, DG Synchronizing panels, UPS, Solar PV panels, IBMS, Rising Main etc. for Offices, Hospitals and Institutional buildings.

One of the special feature of the book is how to determine the size of the LT Cubical Panel (Annexure-XI, XII & XIII).

This book also contains relevant extracts from National Building Codes 2016 including Drawings to increase the utility of the book.

In addition to the guidelines a number of Schematic diagrams, Single line diagrams and Typical layouts have been included in the book to make it more useful.

New Delhi
March, 2019

(C.K. VARMA)
CHIEF ENGINEER CSQ (E)

REFERENCE TO AMENDMENTS

S. No.	Reference under which issued	Para No.	Page No.	Remarks

CONTENTS

Para No.	Name of Para	Page Number
1	Introduction	1-2
2	Objective of modern power distribution system	2
3	Design Considerations	2-6
4	Objective of Uninterrupted Power Supply	6-8
5	Proactive Role by Planning Engineer	8
6	Locating the Receiving Sub-station and Distribution Sub-stations	8
7	Standby systems	8-9
8	Power supply in individual building	9-10
9	Power Supply to Central Air Conditioning Plant	10
10	Power Supply to AHUs	10-11
11	IBMS	11
12	General Note	11
13	Checklist	11-12
	Relevant Extracts from National Building Code-2016	13-16

Annexures

I	Schematic Diagram for 33 kV Receiving Sub-Station feeding number of 11 kV/ 0.433 kV Distribution Substations through 11 kV cabling	17
II	Schematic Diagram for 33 kV Receiving Sub Station feeding number of 33 kV/ 0.433 kV Distribution Sub Stations through 33 kV Cabling	18
III	Typical layout of DG Sets, Sub Station Equipment, AC Plant Room, UPS – Modification to Annexure III of CPWD Substation Specifications, to allow higher sizes of chillers up to 1000 ton, DG Sets up to 2000 kVA, Transformers up to 2500 kVA and UPS up to 2000 kVA	19

IV	Schematic Diagram of 2 X 1000 kVA, 11 kV/0.433 kV Substation	20
V	Schematic Diagram of 33 kV Receiving Sub-Station	21
VI	Schematic Diagram for Sub-Station with Two Transformers and one DG Set & One Essential Panel connecting Essential Loads	22
VII	Schematic Diagram for Sub-Station with 3 Nos. 1000 kVA Transformers feeding 2 nos. sections of Essential LT Panel and One section of non essential LT Panel with 3 nos. 750 kVA DG Sets through Sync. Panels	23
VIII	Typical Layout for 33 kV / 0.433 kV Sub-Station with 33 kV incoming and 2 Nos. 2000 kVA 33 kV / 0.433 kV Transformers	24
IX	Typical Sub-Station Layout for 11 kV/ 0.433 kV Sub-Station with 2 nos. 1000 kVA Transformers and one no. DG Set	25
X	Layout Plan of 33 kV/ 11 kV receiving Sub-Station	26
XI	GAD for a Typical Cubical Panel	27
XII	ACB Construction Guidelines - No. of MCCBs allowed in a vertical switch bay	28
XIII	Calculating Approximate size of Main LT Panel Connected to transformer	29
XIV	Minimum recommended spacing between transformer periphery and Walls	30
XV	Minimum recommended spacing of Switch Board/ Panels from Walls	31
XVI	Typical layout of Sub-station with dry type equipment in a single room	32
XVII	Schematic diagram for Substation Power Distribution	33

GUIDELINES FOR SUBSTATION AND POWER DISTRIBUTION SYSTEM OF BUILDINGS

1. Introduction:

- 1.1 In India commercial use of electricity started in 1891 though it picked up after independence due to large number of thermal and hydro power stations set up in the public sector. The power generation capacity in India has increased from 1362 MW in 1947 to more than 4, 00,000 MW in 2018.
- 1.2 Electricity has become essential for modern life. Practically, like air and water, electricity has become a basic requirement. We require it to run our houses, water supply, lights, fans, domestic appliances, lifts, TV, internet, communication, transportation, hospitals, offices, schools, colleges, industries, infact everything connected with day to day life.
- 1.3 While, in advanced countries availability of quality and uninterrupted power supply is taken for granted, in our country, this is subject to frequent interruptions due to various factors i.e. inadequate supply, inefficient/overloaded power distribution, over loading, use of obsolete technology, inefficient maintenance etc. Often our offices are subject to power interruptions on account of inadequate planning and design and overlooking modern technology including inadequate attention to proper routine and preventive maintenance.
- 1.4 **The parameters for quality electric supply are:**
 - Voltage: steady voltage, variation within permitted limits.
 - Frequency
 - Absence of harmful harmonics
 - Protection against surge/lightning
- 1.5 CPWD for last several decades have been following modern practice for substation and power distribution. While the whole nation has been following pole mounted transformers and overhead distribution, CPWD for last 50 years has been distributing power through indoor substations and underground cabling system. Now the central government wants to change the overhead system into underground system all over the country, responsible for power breakdowns and theft.

1.6 Also, on account of digital and computerised working of our offices and institutions, it has become necessary to provide uninterrupted and quality electric supply.

2. Objective of modern power distribution system:

2.1 To provide quality and uninterrupted power supply to the building so that there is no disruption to the productive operation of various services operating in the building to ensure human comfort.

3. Design considerations.

3.1 Indoor Substations and Underground Cable power distribution:

3.1.1 CPWD substation specifications are based on Indoor substations with standby equipments and UG cabling for ensuring service with minimum breakdowns to overcome the disadvantages of outdoor substations as:

- i) Outdoor substations are subject to dust, rain, storm, extreme heat and theft leading to breakdowns and higher maintenance. During winds, cyclones and storms, the entire distribution system including poles, and conductors collapse taking long time to restore the power supply.
- ii) The indoor substations work at much lower ambient, say at 28 Degree C, when the outside temperature may be above 40 degree C. Similarly the UG cable of power distribution is far superior to overhead system.

3.1.2 Substation with DG Backup: Uninterrupted power supply is supplied by the substation to cater to various loads based on DG Backup and UPS backup. The decision on central vs. building wise UPS provisions are to be taken after careful technical and economical consideration and user requirements. For meeting critical UPS loads which require high quality power input without harmonics/surges etc., suitable Isolating transformer needs to be provided after the UPS.

3.2 DRY V/S Oil cooled transformer:

Oil cooled transformers are not allowed to be located inside the building. They are allowed when the substation is away from the main building. However it is recommended to go for dry transformer in place of oil cooled transformer for following reasons:

- Not prone to fire and explosion thereof.
- Practically maintenance free.

- No wall enclosure for transformer required and substation space requirement is reduced. With VCB HT Panel, dry transformers, the substation layout can be one hall (Annexure- VIII).

(Please also see Enclosed Room Type substation Layout as per NBC 2016 with dry transformers, and without any room enclosures. This takes much less space-Annexure-XVI)

3.3 Voltage stabilization with Transformers with OLTC:

Fluctuating voltage is quite harmful to the equipments. As a standard practice if the supply voltage is less than 380 volts and more than 440 volts, the equipments should be shut down. Therefore transformer with OLTC should be provided as a standard practice for the safety of the equipments. Otherwise, if the voltage level from the supply company has a high variance, absence of OLTC results in provision of hundreds of voltage stabilizers in the building.

3.4 Each Distribution substation to have its DG Back up:

It is recommended that each distribution substation should have its own DG Backup so that in case of mains power failure local DG sets are available as backup as per the normal practice. It is not recommended to have a centralized DG Backup to supply 11 KV DG Power to the distribution substations. This will not allow for segregation of essential and non-essential supply. Also in case of any fault in 11 KV feeder cable the whole campus will have no DG Backup.

3.5 Indoor Vs Outdoor DG Sets:

Indoor DG sets are allowed as per NBC and CPWD specifications. They can be installed indoors or outdoors as decided by technical sanctioning authority after taking into account all relevant considerations. Indoor DG sets can be provided subject to proper smoke exhaust and provision of required quantum of ventilation air. Often, site conditions do not permit installation of DG Sets outdoor. It has become common practice to install DG sets indoors for architectural, aesthetic and security reasons and also for limited outdoor space availability.

3.6 Provision of SCADA PANEL in Substation

For Digital monitoring and data logging of the substation parameters, SCADA Panel should be provided if the additional cost is justified considering its utility.

3.7 Provision of Main LT PANEL: conforming to IS 8623:1993 and other relevant Indian Standards.

All main LT Panels shall conform to **IS 8623:1993 and other relevant Indian Standards** for ensuring proper quality, and shall be of reputed makes.

The manufacturer should possess valid type test certificate from CPRI for the current rating of Busbar equal to or more than the specified current rating.

3.8 APFC PANEL

APFC Panels shall be installed to maintain PF at 0.99 as when PF is improved from 0.8 to 1.0, the load current is reduced by 20 %.

3.9 Advantage of centralization of providing AC Plant, Substation, UPS etc.

The advantage of centralization is to take advantage of diversity factor, standby, lower maintenance and benefit of scale economy. For example, district cooling of the entire campus by one central plant is far more economical than providing a number of plants all over the campus or providing a large number of individual AC Units so is the case with UPS.

3.10 Larger size Units

It is advisable to go for larger capacity equipments like transformers, chillers to reduce number of equipments and overall space requirement of the utility building subject to the requirement, efficiency and life cycle cost analysis duly accounting for the no load losses etc.

3.11 Integrated substation to include transformers, DG Sets, UPS, AC Plant

It is also advisable to adopt integrated substation to reduce interconnection cost, space and operation/maintenance cost. Basic facilities like washroom, toilets for personnel are to be provided.

3.12 Space for future expansion of substation:

Each substation should have provision of addition for at least one transformer and extension of LT Panel to take care of future growth of load.

3.13 Protection against overload, short-circuit, earth leakage and surge:

Power flows from transformer to individual load in following sequence:

- HT Panel to transformer. HT panel with overload/ short-circuit/earth leakage protection of transformer.
- Transformer to LT panel through ACB.
- LT Panel to building main switch through outgoing ACB/MCCB.
- Power is received in building main LT Panel with incoming ACB/MCCB and outgoing MCCB.
- Outgoing MCCB to feed rising main with incoming MCCB.
- Tap-off from rising main at each floor feeds the floor panel with incoming MCCB and outgoing MCCB.
- Outgoing MCCB of floor panel feeds DB with incoming MCCB/MCB and outgoing MCCB/MCB.
- Outgoing from DB feeds the load on light/power circuit.
- Power load at the end of the power circuit is through by MCCB/MCB.
- Therefore the power flows from the transformer to the load through a number of ACBs/MCCBs/MCBs with overload/short-circuit /Earth leakage /Surge protection through properly designed switchboards.

Therefore there may be as many as 12 nos. ACB/MCCB/MCB in series each with overload/short circuit/earth leakage protection before the power is delivered to the load. In a properly designed electric installation, there is complete protection against overload/short-circuit/earth leakage and protection against surge. Electrical fire is on account of overload/short circuit and electrocution is on account of failure of earthing. A properly designed and maintained electrical installation will completely rule out electrical fire and electrocution. Hence these should be taken care during planning and execution.

3.14 Fuse less system:

As per CPWD specifications, only ACBs/ MCCBs/ MCBs are to be used which are fuse less and resettable. Rewirable fuses which are slow to act should not be used being fire hazard. HRC fuses are fast acting, but it is generally seen that they are replaced by rewirable fuses which are fire hazard. HRC fuse switches take much more space compared to MCCBs and due to space constraints, they are not generally used in cubicle panels.

3.15 As per the Government of India guidelines, the Make in India Order-2017 as amended from time to time shall be followed.

4. The objective of uninterrupted power supply is achieved by the following means:

4.1 First, assess power requirement of the building/campus. Keeping reasonable provision for future growth of power which conservatively is about 5% growth per annum. For example, Delhi peak power demand has increased from 4700 MW in 2010 to 7000 MW in 2018-growth of 50 % in 8 years.

4.2 This power will be received at the receiving substation (Grid substation) from the local supply company. Depending on the quantum of power required and local regulations, the power may be supplied at 11KV/33KV/66KV.

4.3 The campus may take about 5 to 10 years to develop the full load so have a flexible contract with the supply company to gradually take care of the growth of load may be explored, the provision for space for extension of substation building during future load may be kept in layout.

4.4 Assessing the load demand:

4.4.1 At the time of preparing initial estimate, load details are not known. There may be substantial variation in load estimate prepared by individual designers. For example, for one campus, one designer may calculate the maximum demand as 10 MVA and the other designer as 15 MVA. The best practical guide is to get actual loading of similar working buildings as watt per sq meter. For electrical loading to include all loads except air-conditioning, based on actual power demand of major CPWD

buildings in Delhi, it is practical to assume 40 watt per sq meter of built-up area, for high load intensity buildings and 25-30 watt per sq meter for medium load intensity buildings.

4.4.2 Load demand should include demand for Air-conditioning. For energy efficient central AC, 40 watt per sq meter of air-conditioned area can be added. If inefficient AC like window/ Split AC/ VRV are adopted about 25 % extra load can be considered. In case of special equipments like medical equipments for hospitals and laboratory equipments for IITs/NITs etc., as a thumb rule 10-15 % may be added to electrical load on this account.

4.4.3 Modern buildings are centrally air-conditioned for ensuring working efficiency, human comfort and better inside air quality. About 50 % of power is spent on AC. Therefore for most efficient Air-conditioning backed by appropriate architecture like envelope insulation to reduce heat load of the building should be adopted.

4.4.4 Also back up arrangement with solar power backup to reduce the Substation KVA and also to reduce electricity bill expenditure are recommended.

4.4.5 For calculation, if the load comes to 10 MVA based on conventional technology, this load may be reduced to 7 MVA by going for energy efficient lighting, fans, appliances, energy efficient AC backed by VFD, BMS, building orientation, insulation etc. This saving of 3 MVA amounts to saving of capital outlay by 6 crores and energy cost saving of 3 crores/year (considering 1 MVA requires energy cost of about 1 crore per year). If we have about 1 to 2 MVA solar backup, the substation MVA is further reduced to 6MVA/5MVA.

4.4.6 Summary of load assessment:

- For electrical loads: 25 to 40 watt per sq meter of built-up area.
- Medical equipments/ laboratory equipment loads: add 25 %.
- Central AC Load: 40 watt per sq meter of AC area subject to energy efficient AC. For inefficient AC like Window/Split AC/VRV add 20 % extra.
- DG aggregate capacity: about 50-60 % of transformer capacity.
- UPS aggregate capacity: 20-25 % of Transformer capacity.

- Solar generation: 5-10 % of transformer capacity but more can be provided if land for solar panels is available.

5. Proactive role by Planning Engineer

The Electrical Engineer has to play a proactive role to reduce the Load requirement of the campus by using appropriate technology and also by coordinating with the architect to provide measures to reduce heat ingress into the building. ECBC code provides guidelines for energy conservation based on selection of energy efficient equipments and various architectural provisions like building orientation, and envelope insulation etc. hence ECBC guidelines are to be followed.

6. Locating the receiving substation and distribution substations:

- 6.1 The receiving substation is to be located in consultation with the supply company and the architect. Generally it is at the periphery of the campus.
- 6.2 Next is to locate the various distribution substations. To reduce voltage drop cabling cost, it is preferable that each substation feeds power up to 200 meters. It is preferable that the substations are independent buildings on ground floor and house supporting services like DG Sets, UPS etc. When it is a part of the main building, it should be located on ground floor as per CPWD specifications and NBC Code. Basement is avoided due to likely flooding during heavy rains however in case basement is selected, arrangements of protection if flooding and pumping out water must be provided.
- 6.3 In a centrally AC building, 50% of the power is consumed by AC. Therefore the plant room should be adjacent to the substation to reduce cost of interconnection.

7. Standby systems:

- 7.1 Any equipment is likely to breakdown so also the electrical. Therefore to maintain supply without interruption, standby systems shall be provided. If the load of the substation is 1000 kVA, 2 nos. 1000 kVA transformers shall be installed, so that in case one transformer breaks down, the other one takes over. Similarly, back up DG set is provided, so that in case of mains power failure, DG Set automatically starts and takes the essential loads. In case of mains power failure, DG set may

take about 30 seconds to start. For such duration, UPS system is provided for ensuring no break supply to UPS Loads. Even the DG Sets and UPS system will have stand by units so that with the combination of Mains supply, DG Sets and UPS we have an uninterrupted power supply system

- 7.2 A modern substation may have 2 or more transformers, 2 or more DG sets and UPS system of adequate capacity all connected to a LT Panel with essential/ non-essential sections, controlled by PLC and electronically monitored by SCADA Panel. A modern substation will generally not require manual switching for day to day operations.
- 7.3 A typical campus will have one 33KV receiving Substation, with one or two incoming 33 KV feeder lines, which is connected to 33 KV HT Panel feeding 33KV/11 KV or 33 KV/0.433 KV transformers as per specific requirement. It may feed about 4 or more distribution substations spread over the campus.
- 7.4 A typical layout of 33 KV substation and various alternate power distribution schematic diagrams are included (Annexure- I & II).
- 7.5 Typical layout of an 11KV/0.433 KV or 33KV/0.433 KV distribution substation is detailed in Substation specifications.
- 7.6 Typical schematic diagram of a substation with HT Panel, Transformers, Bus ducting, LT Panel (Essential and non-essential) , APFC Panel, DG Sets, DG Synchronising Panel, UPS, Battery Room, is enclosed for general guidelines (Annexure- III). Based on specific requirements, these are subject to change.

8. Power supply in individual building

- 8.1 Main LT Room is provided to receive power from the substation.
- 8.2 It will have essential/non-essential/UPS Main Panels to receive and distribute power.
- 8.3 The entire power supply of the building will be controlled from the main LT Room.
- 8.4 Power will be transported vertically through rising mains.
- 8.5 Rising main is technically far superior to rising cable system.

- 8.6 Advantages of rising main compared to cable system:
- Takes much less space.
 - Much less fire hazard, also recommended by NBC.
 - In future, additional power can be tapped from the rising main without laying additional cable.
 - Safe.
 - Technically superior
- 8.7 Next is to decide on a number of rising main shafts. Each shaft will contain following rising mains:
- Essential/ Non-essential
 - Equipment rising main (for hospitals/ Laboratories to feed equipments through dedicated cables.
 - UPS Rising main
- 8.8 At each floor power will be received from rising main through tap off box at the floor panel. The floor Panel will have incoming and outgoing switches to feed the loads.
- 8.9 Also to feed power to the rising mains from the LT Panel, it is preferable to use bus ducting instead of taking a number of cables.
- 9. Power Supply to Central AC Plant**
- 9.1 As in a centrally AC Building, 50 % of power is consumed by AC, AC Main Electrical Panel should be adjacent to the substation to reduce interconnection cost.
- 9.2 The AC Electrical Panel will have two sections, Essential and Non-Essential.
- 9.3 Some chillers along with the pumps and cooling towers will be on Essential supply. As per CPWD specifications, all AHUs will be on DG Supply. Therefore there will be two main incomers in the main AC Panel, duly connected to the Substation LT Panel through Bus ducting.
- 9.4 There will be a main AHU Electrical panel to supply power to the AHUs.
- 10. Power supply to AHUs**
- As per CPWD specifications, all the AHUs will be in vertical alignment, one above the other. There will be a rising main to provide power to the

AHUs. The incoming of each rising main will be connected to the outgoing of AHU Main Panel located in the AC Plant Room. This makes power supply to the AHUs very simple. Also it is very easy to connect the system to the BMS.

11. IBMS

In case of a modern building complex, IBMS may be provided and the entire power distribution can be designed to be IBMS compatible so that the entire system can be monitored and controlled from a centralized location.

12. General Note

Capacities of various equipments worked out as per above guidelines are for the purpose of preparing of preliminary estimate only and are subject to change at the time of preparing Detailed Estimates & Technical Sanction.

13. Checklist

13.1 Total built up area: sq m

Total air conditioned area sq m

Assessed Peak load in KVA: (Preliminary assessment)

- Electrical: kVA
- Air-conditioning kVA
- Special equipment loads
(For hospital, laboratories etc. kVA
- Total Maximum Demand kVA

13.2 Receiving Substation 33 kV:

- Transformer number, Capacity:
- nos Working ...nos standby, Capacity in kVA.

13.3 Distribution substations:

- Numbers
- Substation No. 1:

Transformer capacity and numbers.....

DG Backup, capacity and numbers.....

- Repeat for all Substations like Substation No 2, 3,4,5,6 etc.

Summary:

- Total no. of transformers and aggregate kVA.....
- Total number of DG Sets and aggregate kVA.....
- Provision of future load growth:.....
- Specify spare capacity provided....

13.4 Spare transformer room provided for future expansionYes/No

13.5 Central air-conditioning:

- Total TR capacity of central plant and no of chillers and their capacities proposed including stand by.
- Total Tonnage of central plant ...TR.
- Total number of chillers Nos., specify TR of each.

13.6 UPS Backup:

Total Capacity of UPS (kVA) provided.....

Centralized location or decentralized.....

Give capacity and number of UPS proposed.....

13.7 Solar power planned

Solar power plannedKW

13.8 Architectural coordination to minimise heat ingress: Done:

13.9 Coordination done for selecting energy efficient systems for central AC and other E&M systems to reduce power requirement.

13.10 Compliance with ECBC code provisions for selection of various energy efficient equipments like transformers, cables, AC chillers, appliances etc.

13.11 Summary:

Total of 33 kV Power..... kVA

Total of 11 kV Power.....kVA

Total of DG BackupkVA

Total of UPS backup.....kVA

Total of Solar power proposed.....kVA

RELEVANT EXTRACTS FROM NATIONAL BUILDING CODE 2016

PART 8: Building Services

SECTION 2 : Electrical and Allied Installations

4.1 General:

A competent electrical design engineer should be involved at the planning stage with a view to providing for an installation that will prove adequate for its intended purpose and ensure safety, reliability and energy efficiency in its use.

4.2 Substations and Switch rooms:

4.2.1 Location and Other Requirements

- 2) The substation should preferably be located in a separate utility building and may be adjacent to the generator room, if any. Location of substation in the basement should be avoided, as far as possible.
- 3) In case there is only one basement in a building, the substation /switch room shall not be provided in the basement. Also the floor level of the substation shall not be the lowest point of the basement.
- 12) Oil-filled installation- Substations with oil-filled equipment require great consideration for the fire detection, protection and suppression.
- 12) (i) Substations with oil-filled equipment/apparatus (Transformers and high voltage panels) shall either be located in open or in a utility building. They shall not be located in any floor other than the ground floor or the first basement of a utility building. They shall have direct access from outside the building for operation and maintenance of the equipment.
- 13) Dry-type Installation: In case electric substation has to be located within the main multi-storeyed building itself for unavoidable reasons, it shall be a dry type installation with very little combustible material. Such substation shall be located on the ground floor or on first basement and shall have direct access from the outside of the building for operation and maintenance of the equipment.
- 17) In case of two transformers (dry type or transformers with oil quantity less than 2000 litres) located next to each other without intermittent

wall, the distance between the two shall be minimum 1500 mm for 11 kV, minimum 2000 mm for 22 kV and minimum 2500 mm for 33 kV. Beyond 33 kV, two transformers shall be separated by a baffle wall 4 h fire rating.

- 26) The minimum height of the substation/HV switch room/MV switch room shall be arrived at considering 1200 mm clearance requirement from the top of the equipment to the below of the soffit of the beam.

4.3 Emergency Power Backup System:

4.3.1 Location

The emergency power supply (such as generating sets) should not be allowed to be installed above ground floor or below the first basement level of the building. In case of DG set located in the basement, the ceiling of the basement shall be the ground floor slab. It is preferable to install the standby generator in utility building. If installed in enclosed space, facilities for forced ventilation shall be provided such that there is minimum derating of the equipment. The generating set should preferably be housed adjacent to MV switchgear in the substation building to enable transfer of electrical load efficiently and also to avoid transfer of vibration and noise to the main building.

- 4.3.3 (c) Acoustic enclosure for DG sets/ acoustic lining for DG room shall be in line with the requirements of CPCB. If DG set is located outdoors, it shall be housed in the acoustics enclosures/treatment, reference shall also be made to part 8- Building services, Section 4, Acoustics, Sound Insulation and Noise Control- of the Code.

4.5 Location and Requirements of Distribution Panels:

All distribution panels, switchgears shall be installed in readily accessible position the electrical control gear distribution panels and other apparatus, which are required on each floor may conveniently be mounted adjacent to the rising mains, and adequate space considering clearances required as per 5.3.6.8 shall be provided at each floor for this purpose.

5 Distribution of supply and cabling

5.1.3 In modern building technology, following high demands are made of power distribution system and its individual components:

- a) Long life and service quality
- b) Safe protection in the event of fire
- c) Low fire load
- d) Flexibility in load location and connection but critical in design.
- e) Low space requirement and
- f) Minimum effort involved in carrying out retrofits.

5.1.4 The high load density in modern large buildings and high rise buildings demands compact and safe solution for the supply of power. The use of bus bar trunking system is ideal for such applications. Bus bar trunking can be installed in vertical risers shafts or horizontally in passages for transmission and distribution of power. They allow electrical installations to be planned in a simple and neat member.

Choice of busbar trunking for distribution in buildings can be made on the basis of

- a) reduced fire load (drastically reduced in comparison to the cable system)
- b) reduced maintenance over its entire lifetime
- c) longer service lifetime in comparison with a cable distribution and
- d) enhanced reliability due to rigid bolted joints and terminations and extremely low possibility of insulation failure.

5.3.5 Transformers

5.3.5.1 General design objective while selecting the transformers for a substation should be to provide at least two or more transformers, so that a certain amount of redundancy is built in.

The total installed capacity shall be at least 15 to 20 % higher than the anticipated maximum demand.

With growing emphasis on energy conservation, the system design is made for both extremes of loading. During the periods of lowest load in the system, it would be desirable to operate only one transformer and to subsequently switch on the additional transformer as the load increases during the day.

Total transformer capacity is generally on the basis of present load, possible future load.

The selection of maximum size (capacity) of the transformer is guided by the short circuit making and breaking capacity of the switchgear used in the medium voltage distribution system. Maximum size limitation is important from the aspect of feed to the downstream fault.

5.3.6.3 Where two or more transformers are to be installed in a substation to supply a medium voltage distribution system, the distribution system shall be divided into separate sections, each of which shall be normally fed from one transformer.

Provisions may, however be made to interconnect separate sections through a bus coupler in the event of failure of or disconnections of one transformer.

NBC Code Drawings: See Annexures XIV, XV, XVI

SCHEMATIC DIAGRAM FOR 33 KV RECEIVING SUB-STATION FEEDING NUMBER OF 11 KV/ 0.433 KV DISTRIBUTION SUBSTATIONS THROUGH 11 KV CABLING

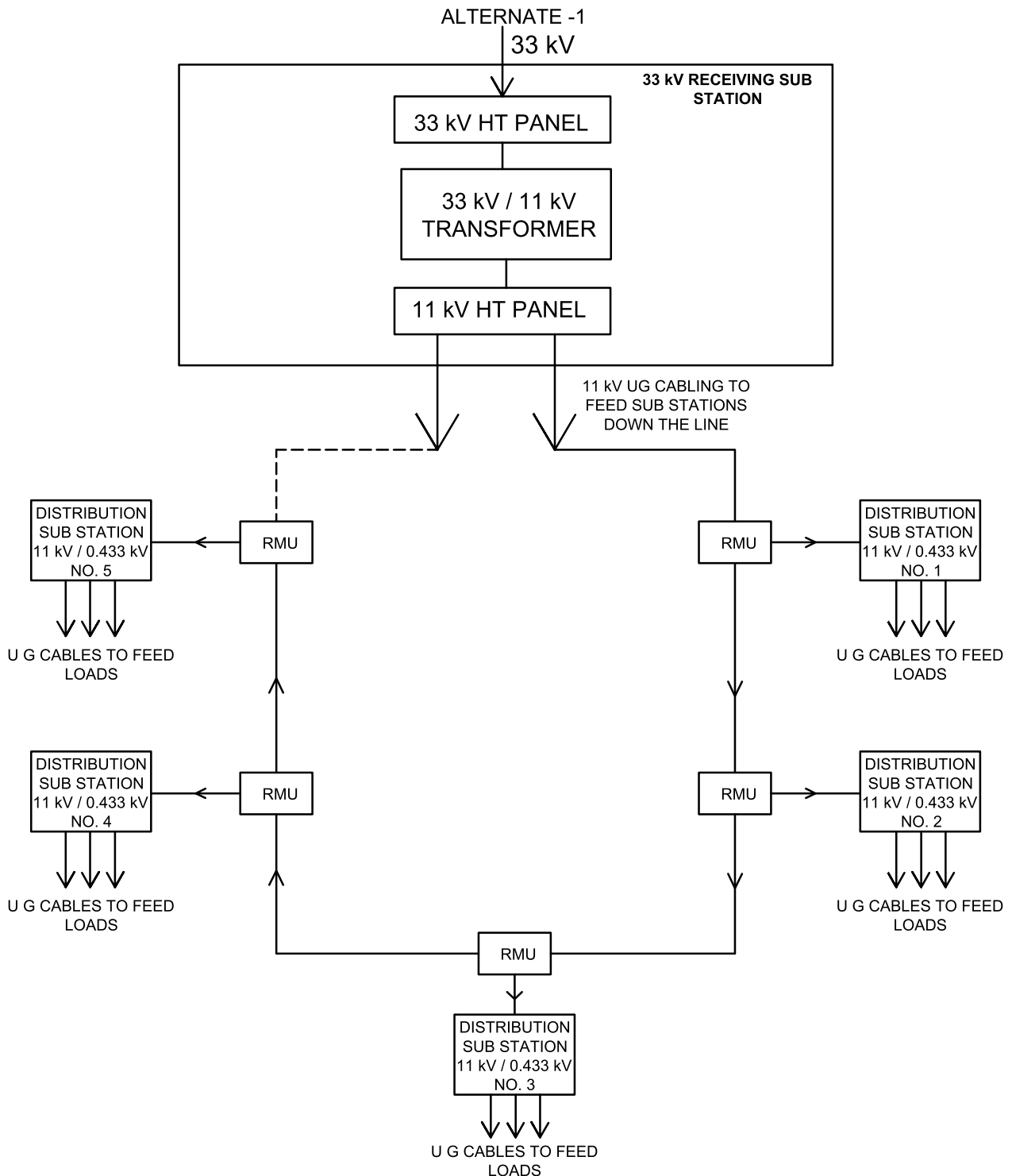

- NOTE: 1) EACH DISTRIBUTION SUB STATION WILL HAVE DG SET AND/OR UPS BACKUP AS REQUIRED
 2) CENTRALIZED DG SET BACKUP AT 11 kV IS NOT RECOMMENDED SINCE IN CASE OF 11 kV CABLE FAULT THE WHOLE CAMPUS WILL HAVE NO DG SET BACKUP AND ALSO THERE WILL BE NON ESSENTIAL SEGREGATION

**SCHEMATIC DIAGRAM FOR 33 kV RECEIVING SUB STATION FEEDING NUMBER OF
33 kV / 0.433 kV DISTRIBUTION SUBSTATIONS THROUGH 33 kV CABLING**

ALTERNATE - 2

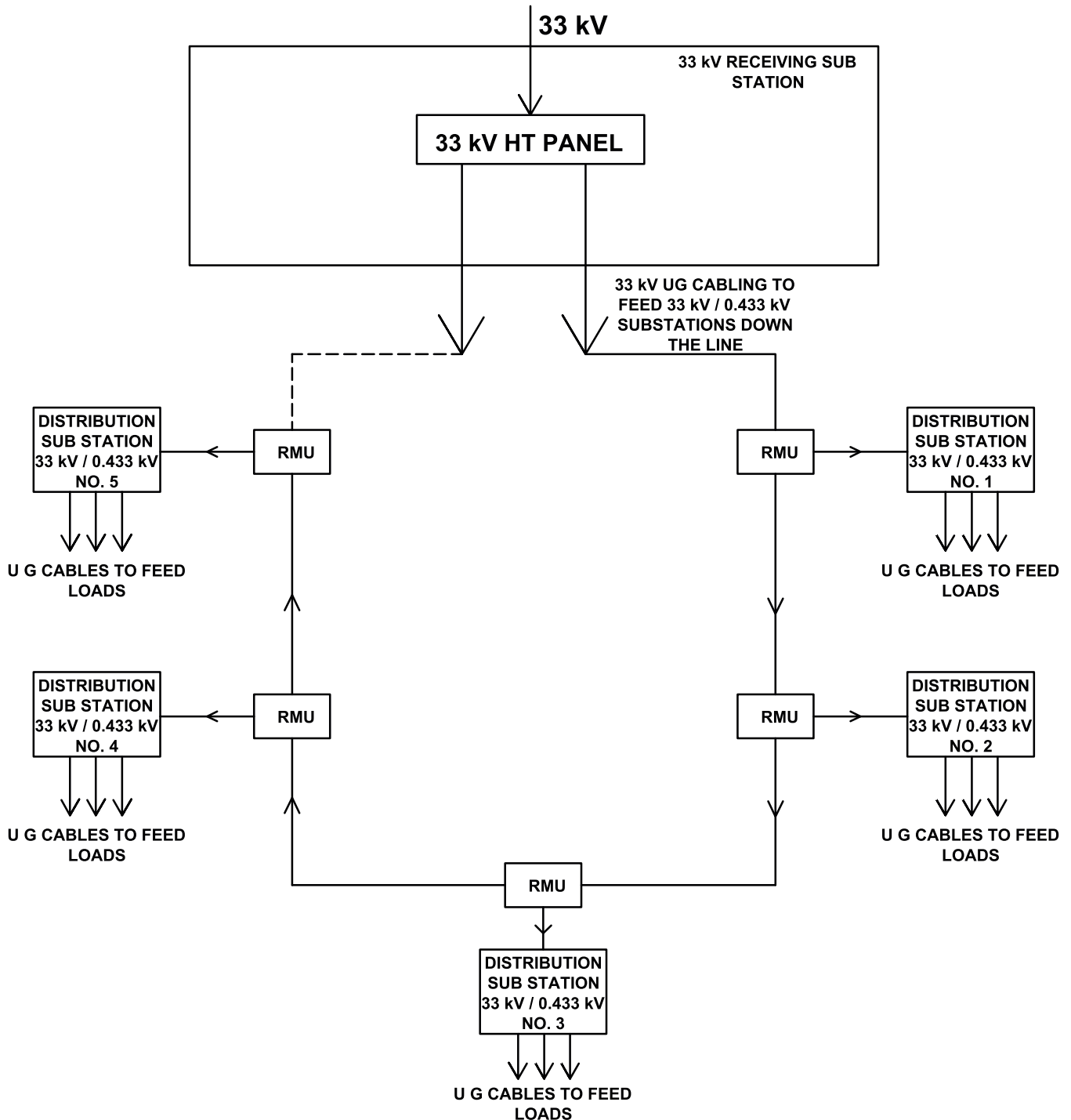

- NOTE :**
- 1) EACH DISTRIBUTION SUB STATION WILL HAVE DG SET AND/OR UPS BACKUP AS REQUIRED
 - 2) CENTRALIZED DG SET BACKUP AT 33 kV IS NOT RECOMMENDED SINCE IN CASE OF 33 kV CABLE FAULT THE WHOLE CAMPUS WILL HAVE NO DG SET BACKUP AND ALSO THERE WILL BE NON ESSENTIAL SEGREGATION
 - 3) CHOOSE BETWEEN ALTERNATE-1 & ALTERNATE -2 AFTER TECHNICAL AND FINANCIAL EVALUATION

**TYPICAL LAYOUT OF DG SETS, SUB STATION EQUIPMENT , AC PLANT ROOM , UPS ,
(MODIFICATION TO ANNEXURE III OF CPWD SUBSTATION SPECIFICATIONS,
TO ALLOW HIGHER SIZES OF CHILLERS UPTO 1000 TON , DG SETS UPTO 2000
KVA , TRANSFORMERS UPTO 2500 KVA, UPS UPTO 2000 KVA)**

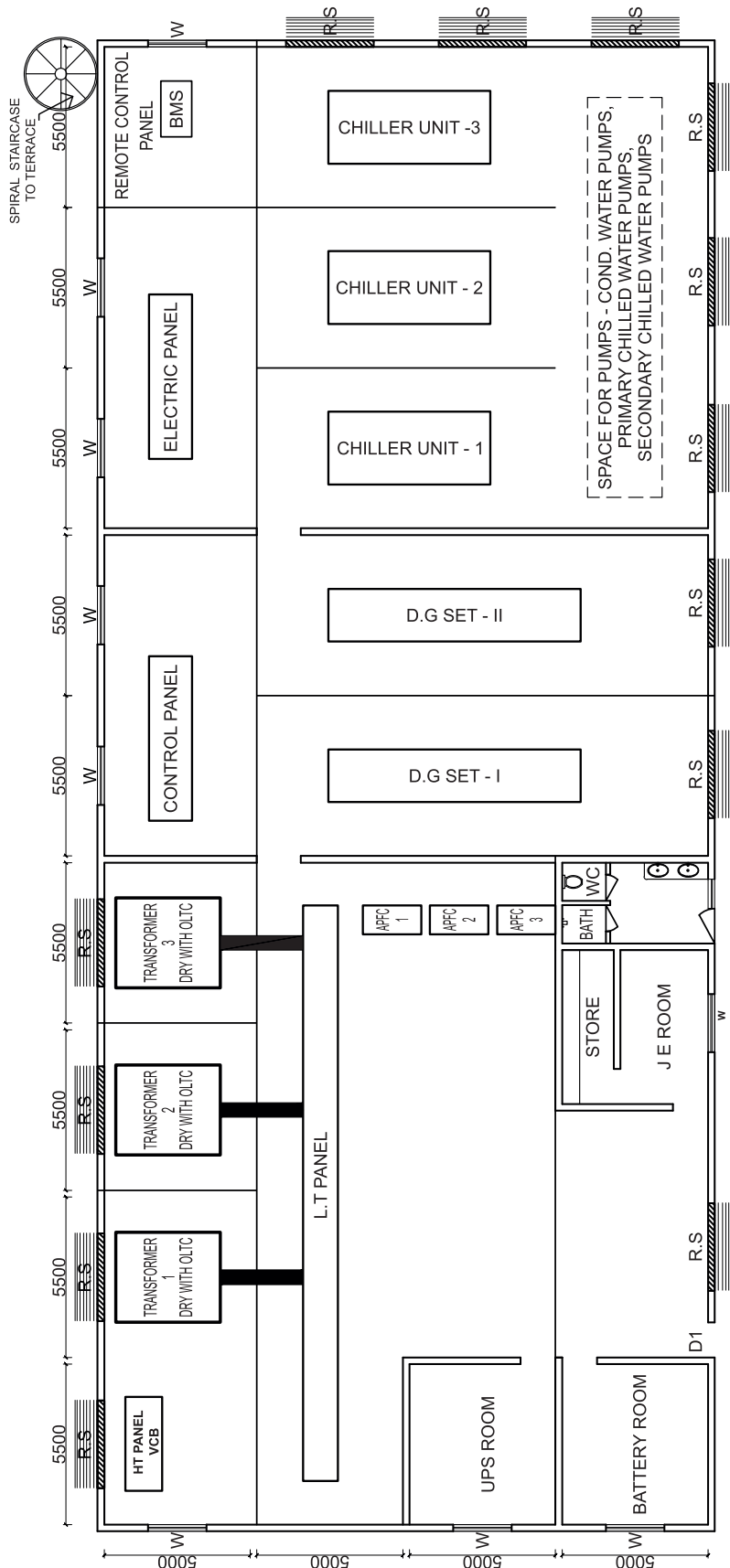

NOTE :

- 1) FLOOR TO CEILING HEIGHT 6.5 m , FLOOR LEVEL 30 cm ABOVE GROUND LEVEL. 2) MOTORABLE CONCRETE APPROACH ROAD ALL ROUND.
- 3) PARTITION WALLS - 30 cm THICK BRICK.
- 5) 1 M WIDE CHAJJA PROTECTION ALL AROUND.
- 7) ALL DOORS OF STEEL WITH FIRE PROTECTION , D1 - 1 m WIDE 2 m HEIGHT.
- 9) CABLE ENTRY PIPES -- EX. ENGINEER WILL GIVE LOCATION AND DETAILS.
- 11) PROTECTION BOUNDARY WALL WITH GATE - IF SUBSTATION IS PROTECTED PREMISES, SUITABLE BOUNDARY WALL WITH GATE SHALL BE PROVIDED.
- 13) 2000 LTRS. WATER TANK ON THE TERRACE WITH WATER CONNECTION.
- 14) COOLING TOWERS WILL BE LOCATED ON THE TERRACE. 15) LOCATE EXHAUST CHIMNEY AND UG BULK STORAGE TANK.
- 4) SPIRAL STAIRCASE TO TERRACE FOR TERRACE MAINTENANCE AND APPROACH TO EQUIPMENT ON TERRACE.
- 6) ROLLING SHUTTER - 3 m WIDE - 3.5 m HEIGHT AS PER ANNEXURE X OF CPWD SPECS. WITH VENTILATION GRIDS.
- 8) W - WINDOW - NORMAL SIZE WITH GRILL.
- 10) CABLE TRENCHES - EX. ENGINEER WILL GIVE DETAILS.
- 12) STORE SHELVES - 0.75 m DEEP, RCC 1m , 2m , 3m ABOVE GROUND LEVEL.

**SCHEMATIC DIAGRAM OF 2 X 1000 kVA 11 kV / 0.433 kV
SUBSTAION**

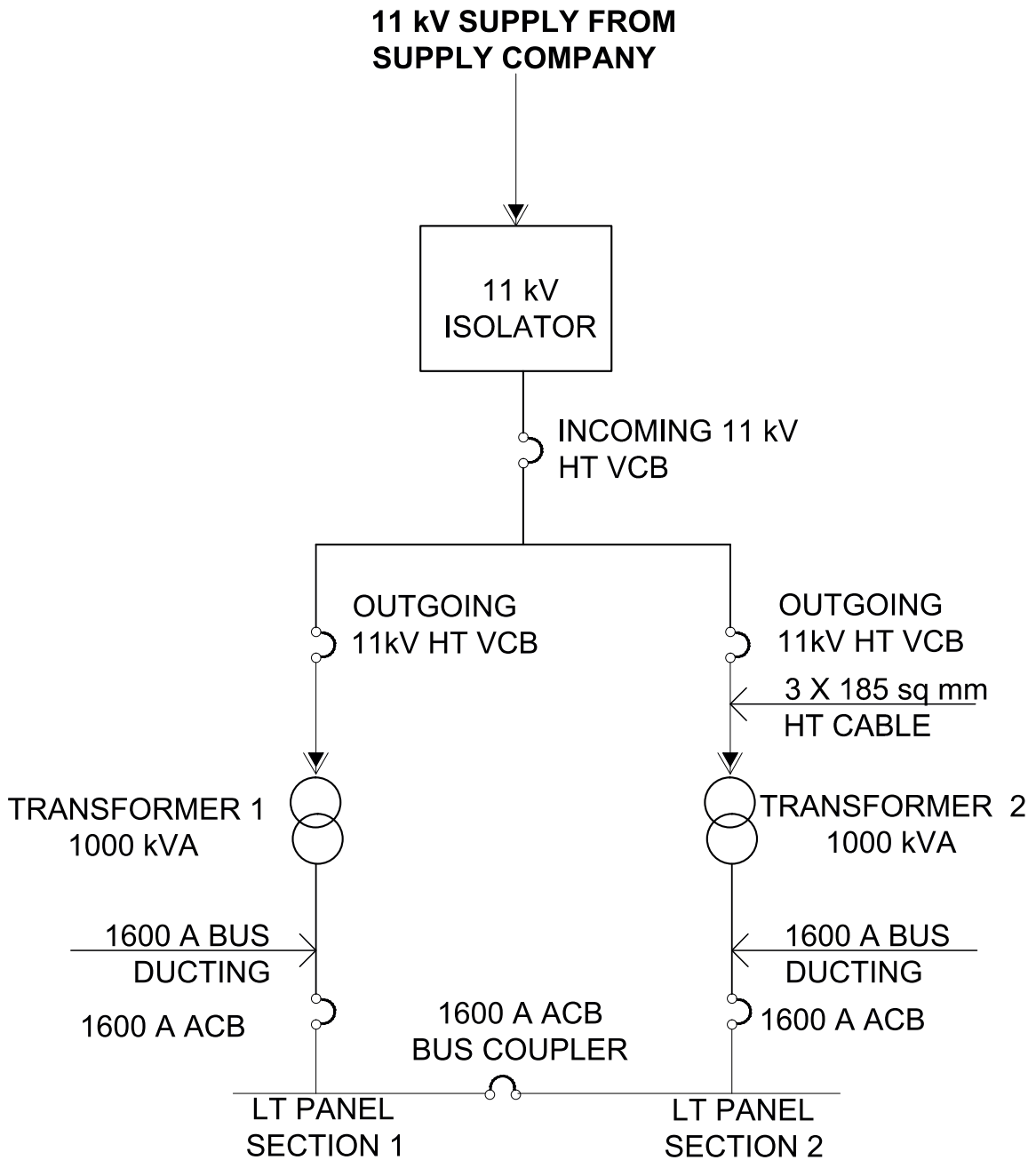

ANNEXURE-V

SCHEMATIC DIAGRAM OF 33 kV RECEIVING SUBSTATION

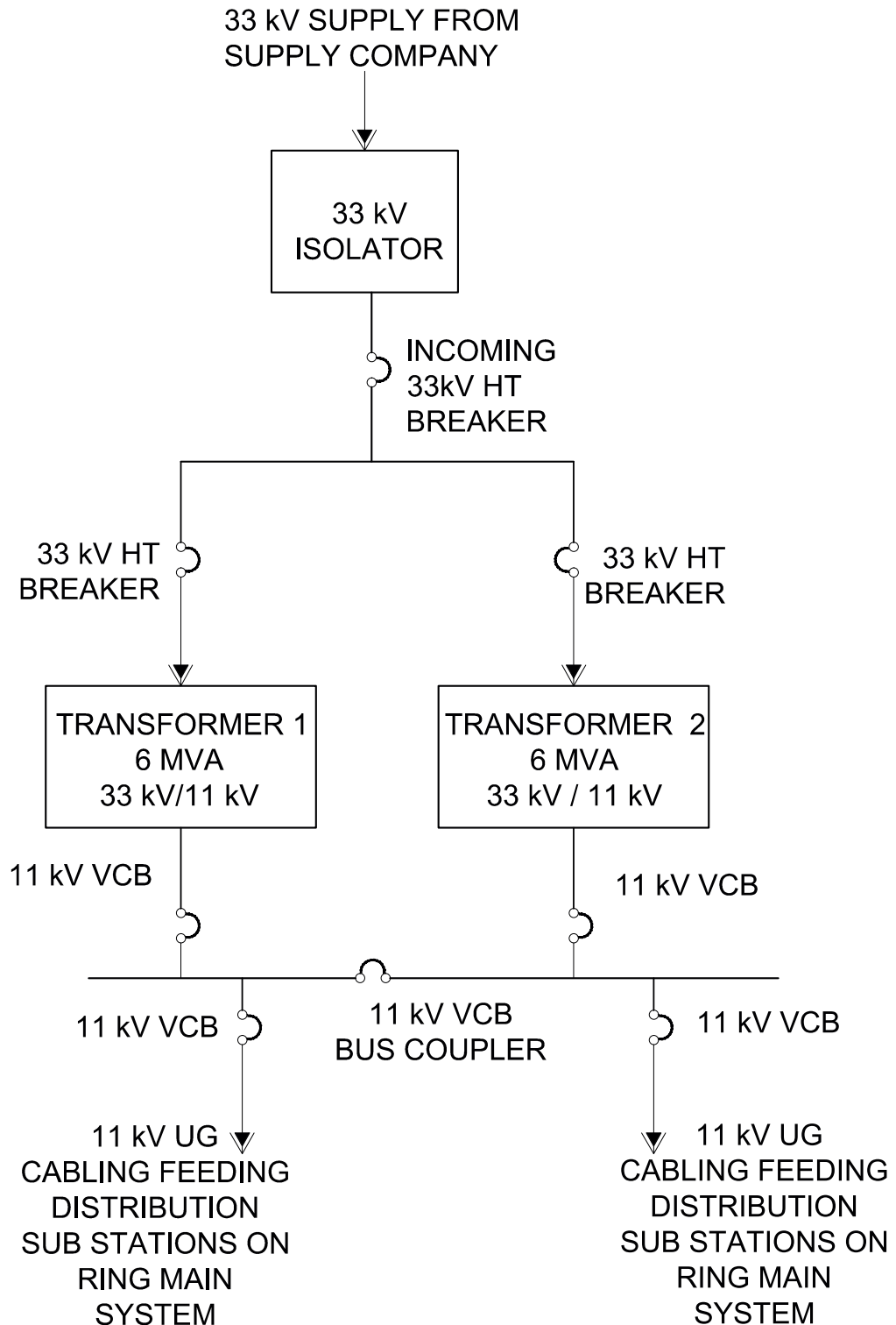

ANNEXURE-VI

SCHEMATIC DIAGRAM FOR SUB STATION WITH TWO TRANSFORMERS AND ONE DG SET & ONE ESSENTIAL PANEL CONNECTING ESSENTIAL LOADS

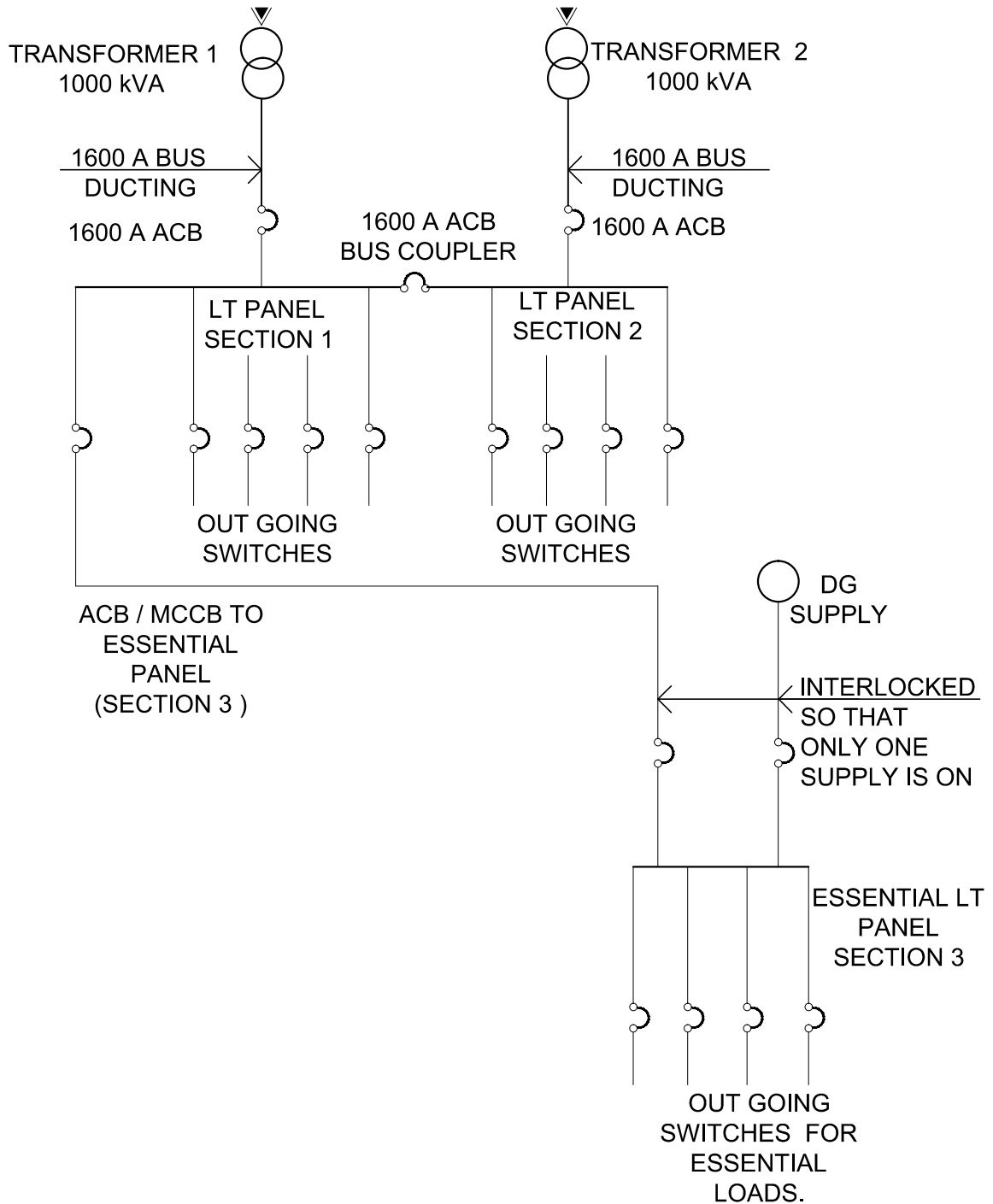

SCHEMATIC DIAGRAM OF SUBSTATION WITH 3 NOS. 1000 kVA TRANSFORMERS FEEDING 2 NOS. SECTIONS OF ESSENTIAL LT PANEL AND ONE SECTION OF NON ESSENTIAL LT PANEL WITH 3 NOS. 750 kVA DG SETS THROUGH SYNC. PANELS.

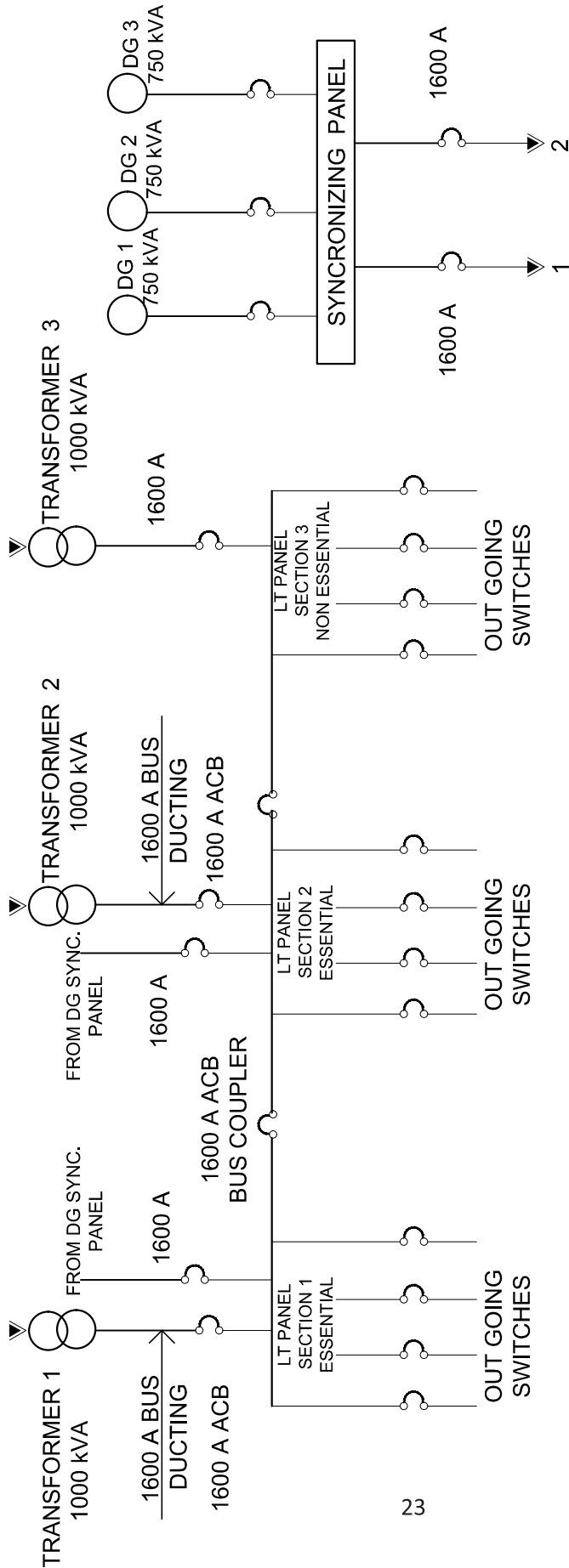

NOTE : 1) THE ENTIRE SYSTEM IS CONTROLLED / MONITORED THROUGH PLC / SCADA PANELS.
 2) ALL SWITCHES ABOVE 800 A WILL BE ACB AND UP TO 800 A WILL BE MCCB.

ANNEXURE-VIII

TYPICAL LAYOUT FOR 33 kV / 0.433 kV SUBSTATION WITH 33 kV INCOMING AND 2 NOS. 2000 kVA 33 kV / 0.433 kV TRANSFORMERS

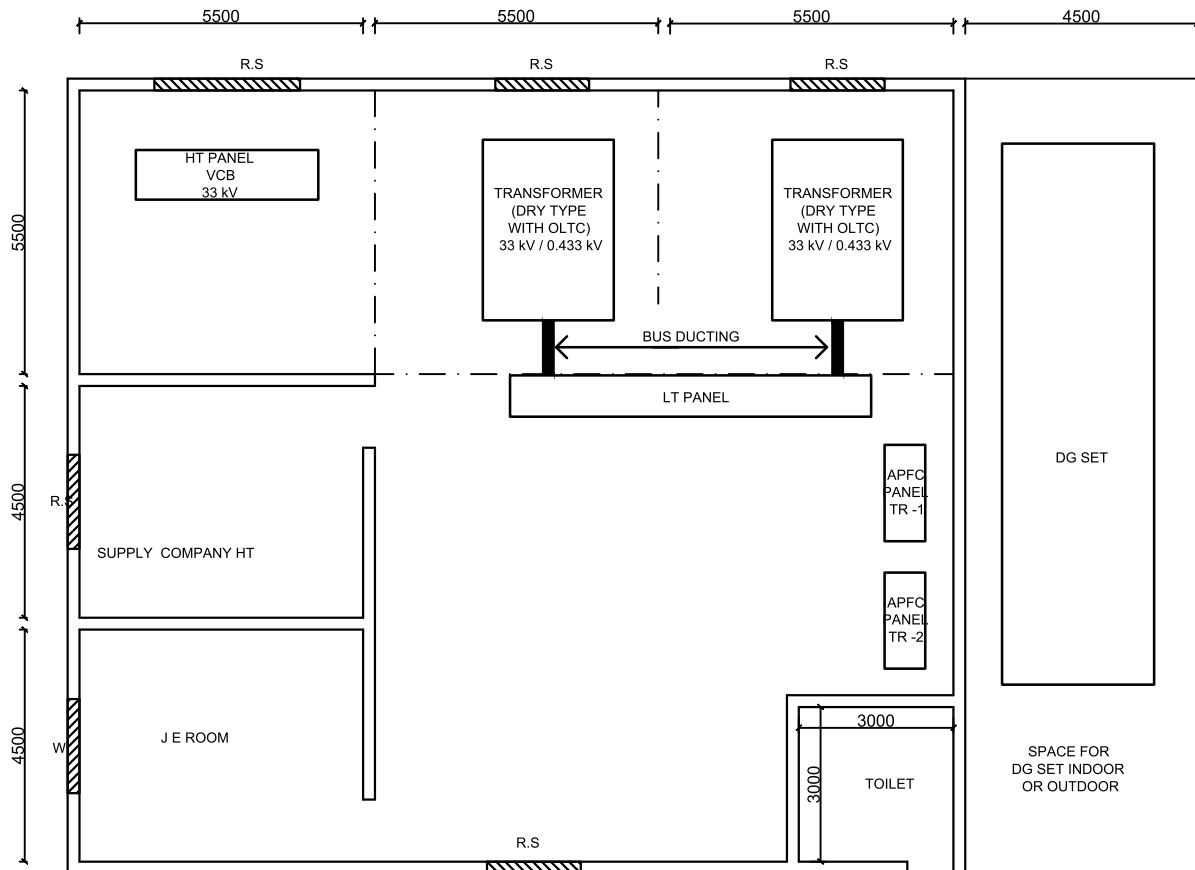

NOTE :

- 1) FLOOR TO CEILING HEIGHT 4.5 m.
- 2) FLOOR LEVEL 30 cm FROM GROUND LEVEL.
- 3) MOTARABLE CONCRETE APPROCH ROAD ALL AROUND.
- 4) TRANSFORMER DRY TYPE WITH OLTC. HENCE NO WALL ENCLOSURE PROVIDED.
- 5) DRY TRANSFORMER IS VERY USEFUL FOR REDUCING FIRE HAZARD. NO WALL ENCLOSURE IS REQUIRED, WHICH REDUCES SUB STATION SPACE.
- 6) OTHER BUILDING REQUIREMENTS AS PER CPWD SPECIFICATIONS FOR SUB STATIONS VIDE ANNEXURE - I.
- 7) IN CASE OF TRANSFORMER 1600 kVA OR MORE THE TRANSFORMER ROOM SIZE MAY BE INCREASED TO 5m X 5m.
- 8) ALL DIMENSIONS ARE IN mm.

ANNEXURE IX

TYPICAL SUBSTATION LAYOUT FOR 11 kV / 0.433 kV SUB STATION WITH 2 NOS 1000 kVA TRANSFORMER AND ONE DG SET

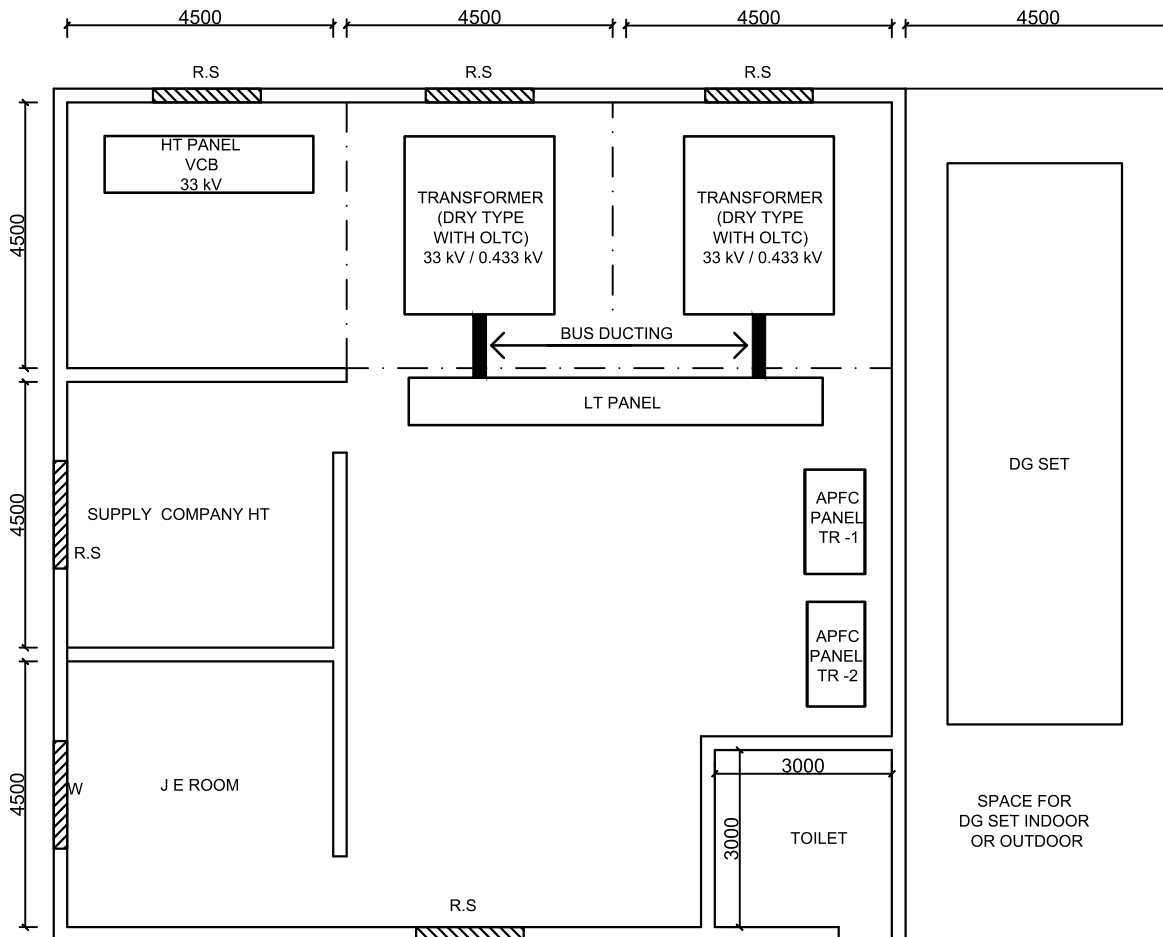

NOTE :

- 1) FLOOR TO CEILING HEIGHT 4.5 m
- 2) FLOOR LEVEL 30 cm FROM GROUND LEVEL
- 3) MOTARABLE CONCRETE APPROCH ROAD ALL AROUND
- 4) TRANSFORMER DRY TYPE WITH OLTC . HENCE NO WALL ENCLOSURE PROVIDED
- 5) DRY TRANSFORMER IS VERY USEFUL FOR REDUCING FIRE HAZARD. NO WALL ENCLOSURE IS REQUIRED , WHICH REDUCES SUB STTION SPACE.
- 6) OTHER BUILDING REQUIREMENTS AS PER CPWD SPECIFICATIONS FOR SUB STATIONS VIDE ANNEXURE I
- 7) IN CASE OF TRANSFORMER 1600 kVA OR MORE THE TRANSFORMER ROOM SIZE MAY BE INCREASED TO 5 m X 5 m
- 8) ALL DIMENSIONS ARE IN mm.

LAYOUT PLAN OF 33 kV/ 11 kV RECEIVING SUBSTATION

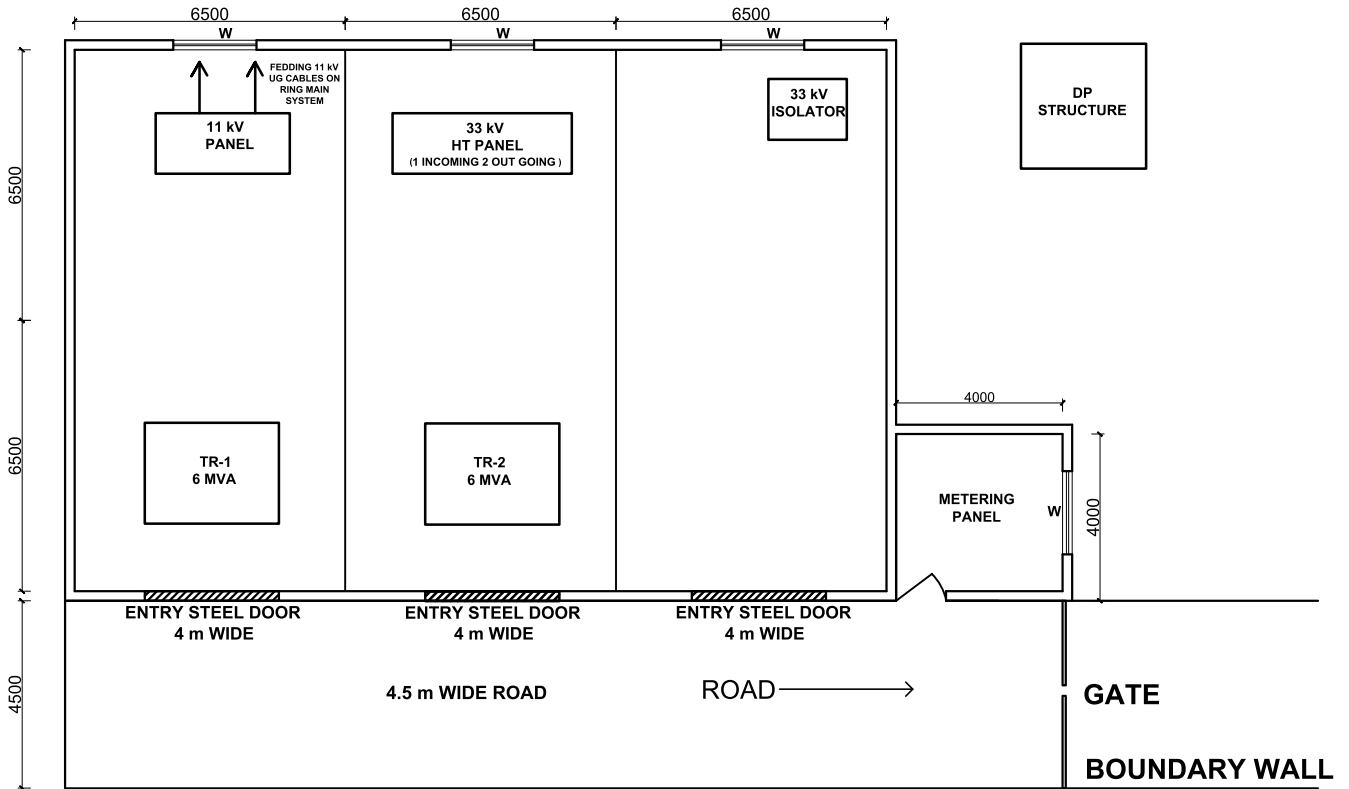

NOTE :

- 1) THIS IS A SUGGESTED LAYOUT PLAN WITH 1 INCOMING 33 kV OVERHEAD PLAN AND INDOOR 33 kV SUBSTATION WITH 33 kV HT PANEL FEEDING 2 NOS. 6 MVA 33 kV / 11 kV TRANSFORMERS (1 STANDBY) FEEDING 11 HV HT PANEL .
- 2) THE 11 kV HT PANEL WILL FEED DISTRIBUTION SUB STATIONS DOWN THE LINE WITH UG CABLING ON RING MAIN SYSTEM.
- 3) THIS IS SUBJECT TO CHANGE TO SUIT LOCAL CONDITIONS AND REQUIREMENTS.
- 4) 33 kV DRY TRANSFORMERS ARE AVAILABLE AND PREFERABLE TO REDUCE FIRE HAZARD.
- 5) THIS IS SECURITY PREMISES. REQUIRES SUITABLE BOUNDARY WALL/ LOCKABLE GATES.
- 6) FLOOR TO CEILING HEIGHT 5m
- 7) FLOOR LEVEL 60 cm FROM GROUND LEVEL
- 8) ALL DIMENSIONS ARE IN mm.

ANNEXURE XI

GAD FOR A TYPICAL CUBICAL PANEL

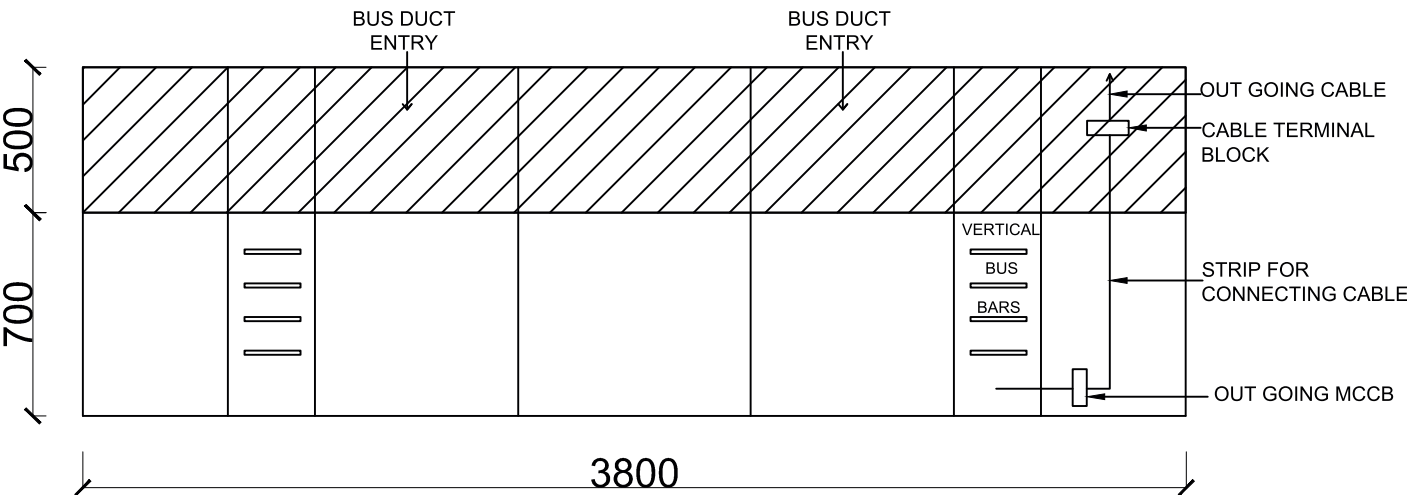
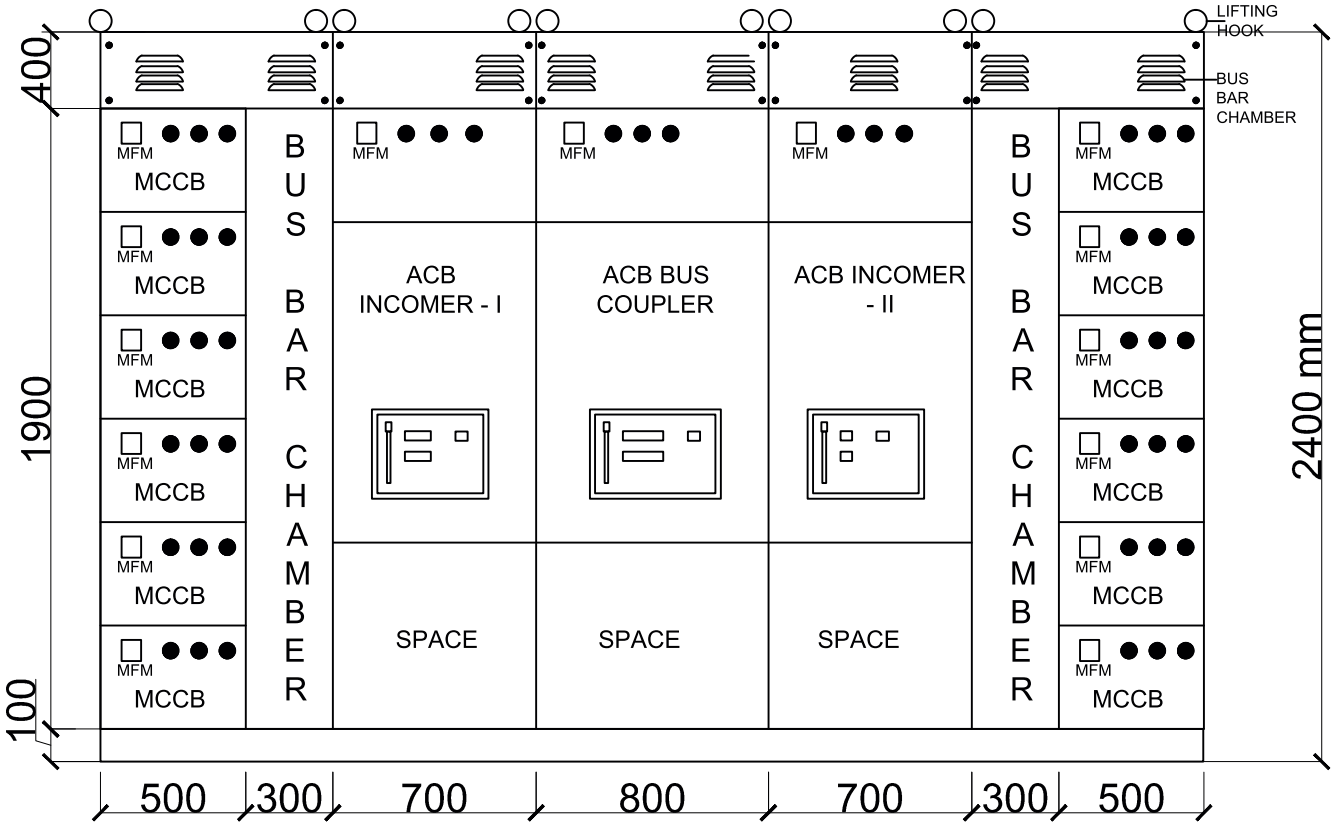

NOTE : ALL DIMENSIONS ARE IN mm.

ACB CONSTRUCTION GUIDELINES

ACB RATING	WIDTH OF COMPARTMENT (in mm)	WIDTH OF BUS COUPLER (in mm)	MAIN BUS BAR	MOUNTING ARRANGEMENT	INCOMING CONNECTION
800 A	700	800	1000 A	DOUBLE TIER (SINGLE TIER IF ACB IS INCOMER)	CABLE ENTRY/BUS DUCT AS SPECIFIED
1000 A	700	800	1250 A	DOUBLE TIER (SINGLE TIER IF ACB IS INCOMER)	CABLE ENTRY/BUS DUCT AS SPECIFIED
1250 A	700	800	1600 A	DOUBLE TIER (SINGLE TIER IF ACB IS INCOMER)	CABLE ENTRY/BUS DUCT AS SPECIFIED
1600A	700	800	2000 A	SINGLE TIER	CABLE ENTRY/BUS DUCT AS SPECIFIED
2000 A	800	900	2500 A	SINGLE TIER	BUS DUCT ENTRY
2500 A	800	900	3000 A	SINGLE TIER	BUS DUCT ENTRY
3200A	900	1000	4000 A	SINGLE TIER	BUS DUCT ENTRY
4000 A	1000	1100	5000 A	SINGLE TIER	BUS DUCT ENTRY

NO. OF MCCBs ALLOWED IN A VERTICAL SWITCH BAY

MCCB RATING IN A	WIDTH OF COMPARTMENT IN mm	NO. OF MCCB'S ALLOWED IN A BAY	INCOMING CONNECTION FROM BUS BAR TO MCCB	CONNECTION FROM MCCB TO OUTGOING TERMINAL BLOCK
100- 200 A MCCB	400	6	Al / Cu wire or strip	Al / Cu wire or insulated strip duly supported
ABOVE 200 -400 A MCCB	500	5	Al / Cu insulated strip	Al / Cu insulated strip duly supported
ABOVE 400 -630 A MCCB	500	4	Al / Cu insulated strip	Al / Cu insulated strip duly supported
800 A MCCB	600	2	Al / Cu insulated strip	Al / Cu insulated strip duly supported
ABOVE 800 A MCCB	NOT TO BE USED, USE ACB IN CASE OF MORE THAN 800 A			

- NOTE:** 1) MCCBs UPTO 200 A TO BE OF THERMAL MAGNETIC TYPE WITH ADJUSTABLE OVERLOAD AND ADJUSTABLE SHORT CIRCUIT PROTECTION.
 2) MCCBs ABOVE 200 A TO BE MICRO PROCESSOR BASED WITH ADJUSTABLE OVERLOAD, ADJUSTABLE SHORT CIRCUIT PROTECTION AND INBUILT EARTH FAULT PROTECTION.

**CALCULATING APPROXIMATE SIZE OF MAIN LT PANEL CONNECTED
TO TRANSFORMER**

- 1) FIND THE NUMBER OF INCOMERS AND BUS COUPLERS REQUIRED.
- 2) FOR EACH INCOMER AND BUS COUPLER ONE BAY IS REQUIRED.
- 3) ONE SECTION FOR EACH TRANSFORMER.
- 4) FOR EACH SECTION, FIND THE NUMBER OF OUTGOING SWITCHES REQUIRED AND THEIR AMPERAGE.
- 5) AS PER GUIDELINES ABOVE, FIND THE NUMBER OF SWITCH BAYS REQUIRED.
- 6) CALCULATE THE TOTAL NUMBER OF BUS BAR BAYS, SWITCH BAYS, INCOMER BAYS, BUS COUPLER BAYS REQUIRED.
- 7) BASED ON ABOVE GUIDELINES, MAKE A GAD (GENERAL ARRANGEMENT DRAWING) AND FIND THE OVERALL DIMENSIONS OF THE PANEL.
- 8) EVERY INCOMING AND OUT GOING SWITCH WILL HAVE MFM AND PHASE INDICATING LAMPS.

MINIMUM RECOMMENDED SPACING BETWEEN THE TRANSFORMER PERIPHERY AND WALLS

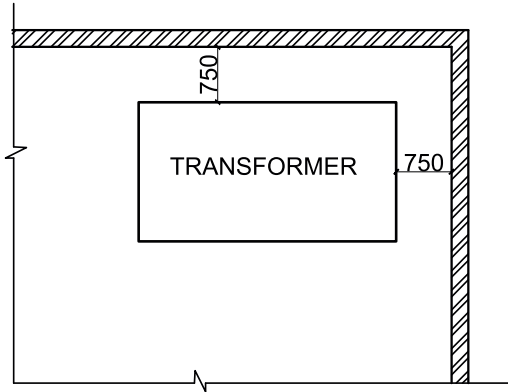

TRANSFORMER WITH WALL ON TWO SIDES

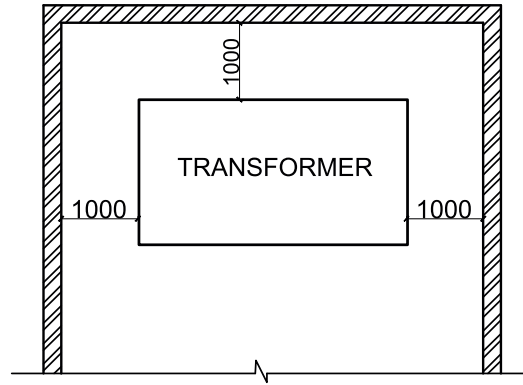

TRANSFORMER WITH WALL ON THREE SIDES

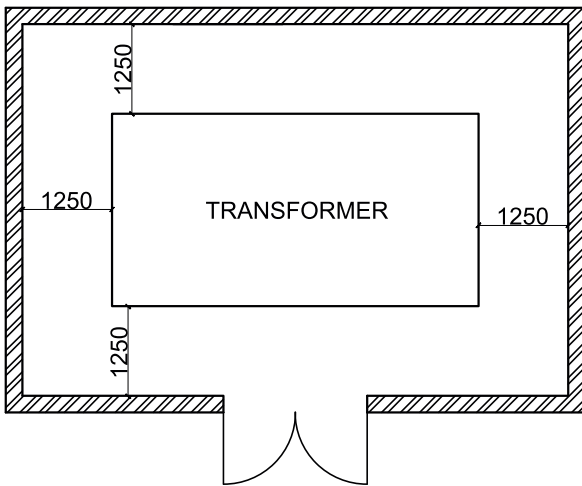

TRANSFORMER IN ENCLOSED ROOM

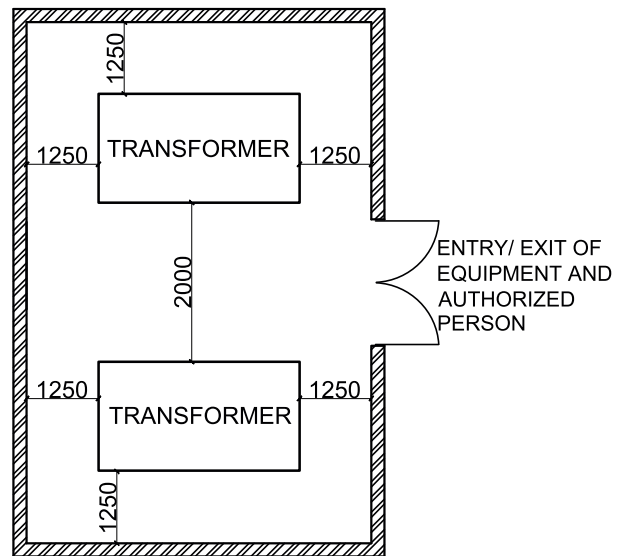

MULTIPLE TRANSFORMERS IN A ROOM

NOTE - ALL DIMENTIONS ARE IN mm

MINIMUM RECOMMENDED SPACING OF SWITCH BOARD / PANELS FROM WALLS

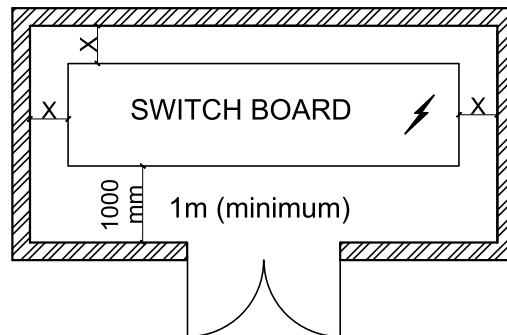

ONE SWITCH BOARD/ PANEL

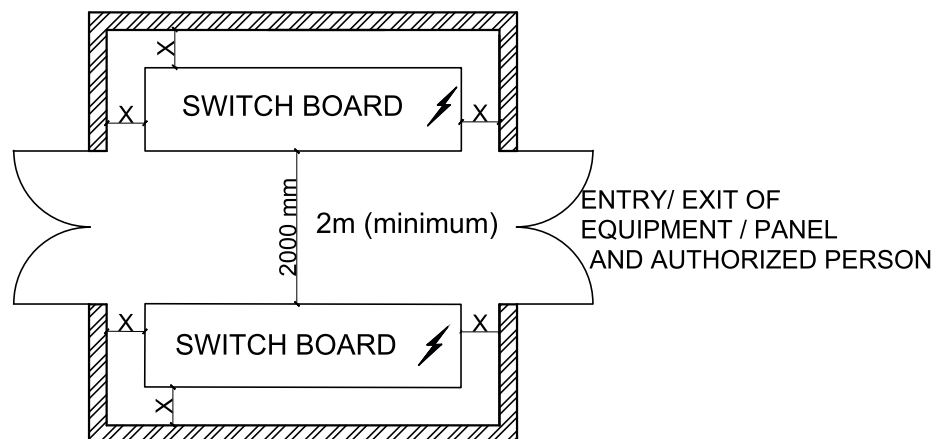

**TWO SWITCH BOARD/ PANELS
FACING EACH OTHER**

'X' is : LESS THAN 200 mm (IF SWITCH BOARD /PANEL IS NOT ACCESSIBLE FROM BEHIND)
: MORE THAN 750 mm (IF SWITCH BOARD /PANEL IS ACCESSIBLE FROM BEHIND)

NOTE - X TO BE MEASURED FROM THE FARTHEST PROTRUDING PART OF ANY ATTACHMENT OR CONDUCTOR.

TYPICAL LAYOUT OF SUBSTATION WITH DRY TYPE EQUIPMENT IN A SINGLE ROOM

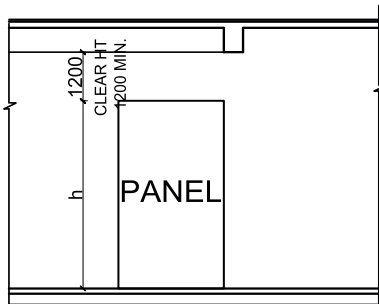

PANEL ROOM (ELEVATION)
(All dimensions are in mm)

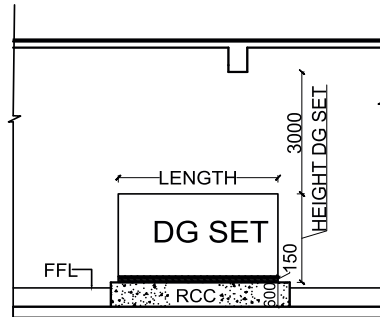

DG ROOM (ELEVATION)

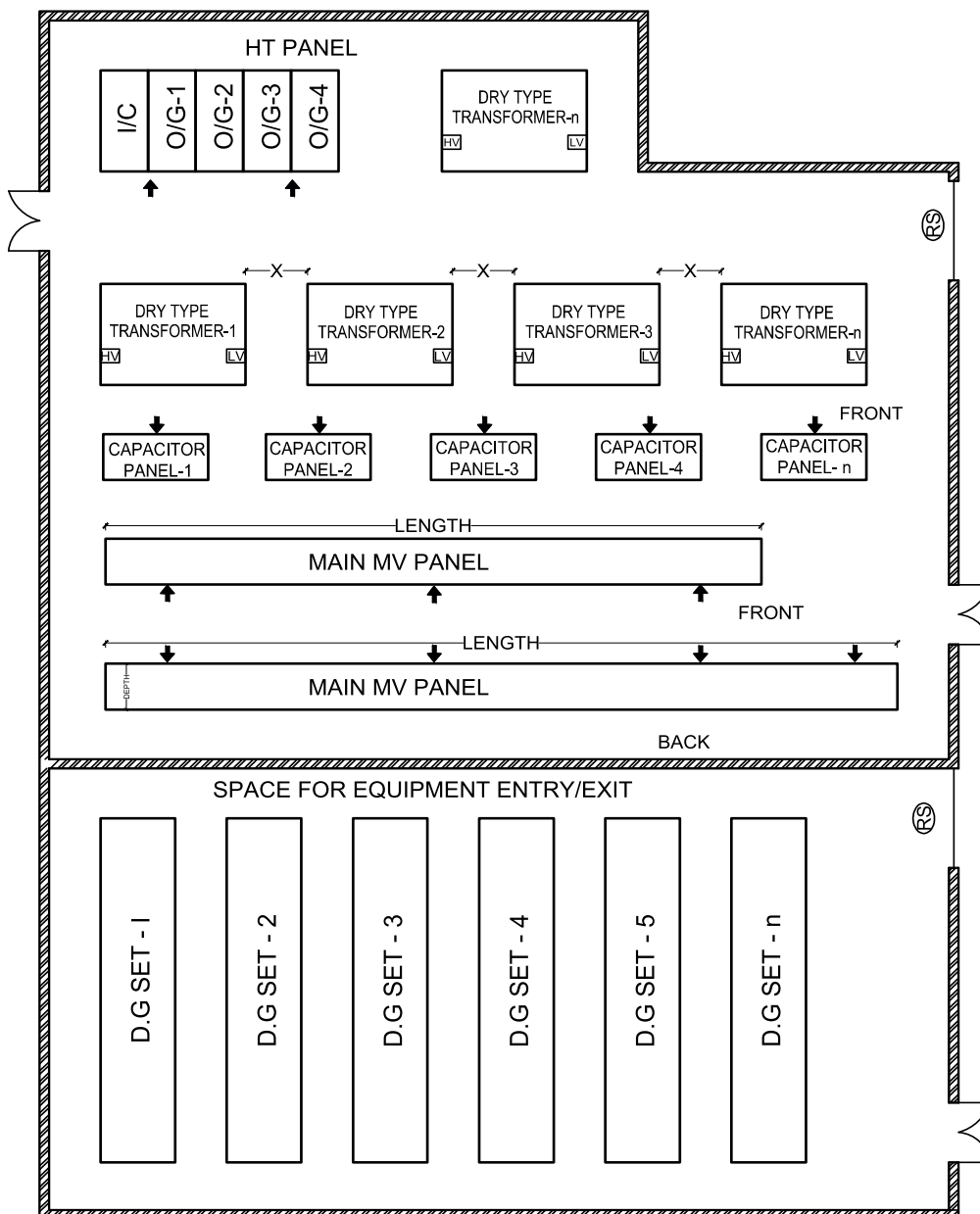

Note : X = 2500 mm minimum in case of 33 kV and 1500 mm minimum in case of 11 kV Transformers respectively.

**TYPICAL SCHEMATIC DIAGRAM FOR SUBSTATION
POWER DISTRIBUTION**

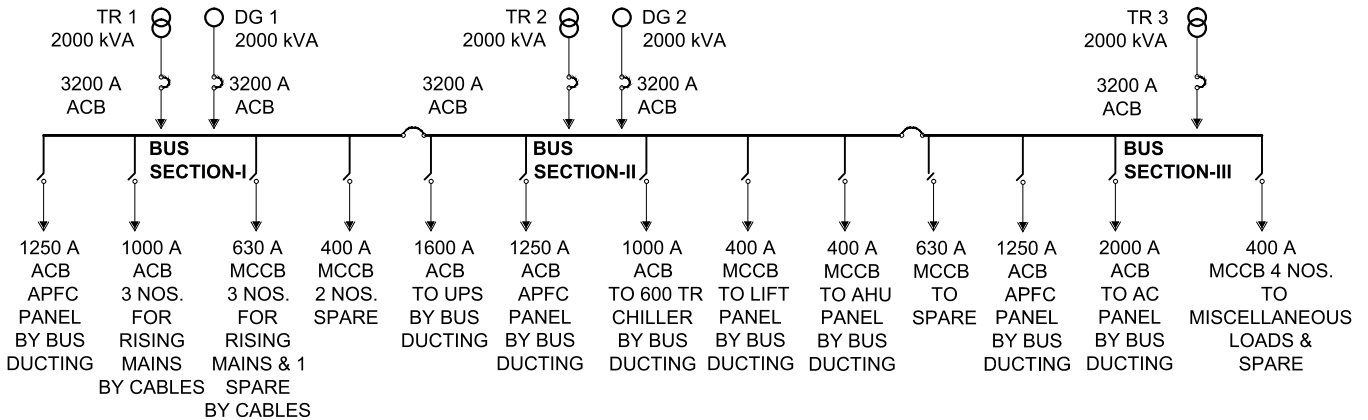

SCHEMATIC DIAGRAM FOR UPS

FROM BUS SECTION-II
MAIN LT PANEL

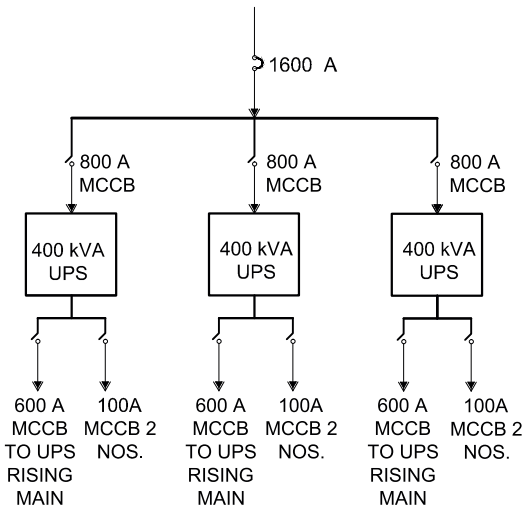

11 KV HT DISTRIBUTION

11 KV SUPPLY FROM
SUPPLY COMPANY

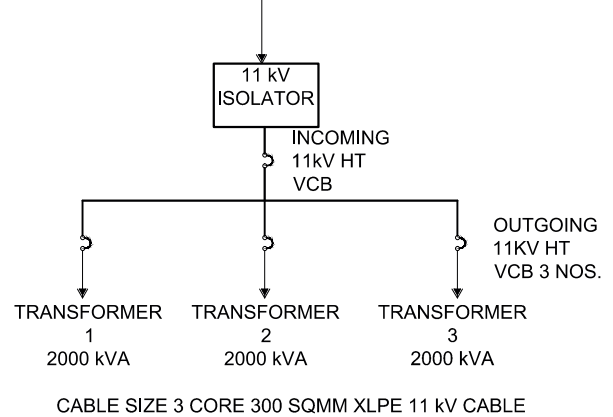

**33 KV RECEIVING SUBSTATION
SCHEMATIC DIAGRAM**

33 KV SUPPLY FROM
SUPPLY COMPANY

