



GENERAL SPECIFICATIONS FOR ELECTRICAL WORKS



PART-V (WET RISER & SPRINKLER SYSTEMS)

2020



**CENTRAL PUBLIC WORKS DEPARTMENT
MINISTRY OF HOUSING & URBAN AFFAIRS**



सत्यमेव जयते

भारत सरकार

GOVERNMENT OF INDIA

केन्द्रीय लोक निर्माण विभाग

CENTRAL PUBLIC WORKS DEPARTMENT

वैद्युत कार्यों

के लिए

सामान्य विनिर्देश

भाग-V (आर्द्र राइजर एवं स्प्रिंकलर प्रणाली)

CPWD GENERAL SPECIFICATIONS

FOR

ELECTRICAL WORKS

PART-V (WET RISER &

SPRINKLER SYSTEMS)

2020



महानिदेशालय, के. लो. नि. वि., निर्माण भवन, नई

दिल्ली-110011

DIRECTORATE GENERAL, CPWD, NIRMAN BHAWAN, NEW DELHI-110011

All rights reserved. No part of this publication may be reproduced in any form or by any means, electronic or mechanical, including photocopy, recording or any information storage and retrieval system, without permission, in writing from the Director General, CPWD, New Delhi.

GOVERNMENT OF INDIA PUBLICATION

Published under the authority of

Director General
Central Public Works Department
Nirman Bhawan, New Delhi-110011



Vinit Kumar Jayaswal
Director General



सत्यमेव जयते

भारत सरकार
Government of India



केन्द्रीय लोक निर्माण विभाग
निर्माण भवन, नई दिल्ली-110011
Central Public Works Department
Nirman Bhawan, New Delhi-110011
Tel : 23062556/1317, Fax : 23061884
E-mail : cpwd_dgw@nic.in

FOREWORD

We are responsible for design, construction and maintenance of a large number of government buildings. High rise buildings have become common in urban areas due to the scarcity of land. Most of these buildings are equipped with extensive E&M and air conditioning services. The fire alarm system and fire fighting arrangements are, therefore, essential in designs of such buildings.

Specifications for water based fixed type fire fighting installations were published first in the year 1985. Since then, there had been major changes in the water based fire fighting systems with the introduction of sprinkler systems for basement and auditorium. National Building Code, 2005 had also introduced additional safety measures, which led to revision of these specifications in 2006.

National Building Code was again revised in the year 2016. Thus the need was felt to modify the specifications for fixed type fire fighting installations to update the various provisions and to bring the specifications at par with the modern technological developments and to incorporate the revisions made in IS: 13039 and IS: 15105.

These Specifications provide complete information on concept, design, installation, testing, commissioning and maintenance of firefighting system which will be very useful to our field officers.

I express my sincere gratitude to Shri Sudhir Kumar Chawla, Director General (In-Situ) and Chairman, E&M Specifications Committee for his dedicated efforts in revising these Specifications. I also acknowledge the hard work and contribution of Shri C K Varma, CE(E)CSQ and Shri D K Tulani, SE(E)TAS in preparing the draft and revising these Specifications under the guidance of Shri Anant Kumar, ADG (Tech).

Suggestions for modifications as well as errors and omissions may be sent to SE(E) TAS, office of the Chief Engineer (E), CSQ, CPWD, New Delhi.

Place: New Delhi
Dated: September, 2020

(Vinit Kumar Jayaswal)
Director General



Sudhir Kumar Chawla
Chairman
(Specifications Committee)



भारत सरकार
Government of India



केन्द्रीय लोक निर्माण विभाग
Central Public Works Department
कार्यालय महानिदेशक (यथावत्)
Office of Director General (In-Situ)
केन्द्रीय सदन, सेक्टर-9A,
Kendriya Sadan, Sector-9A,
चंडीगढ़-160009
Chandigarh-160009

PREFACE

The CPWD General Specifications for Electrical Works- Part – V (Wet Riser & Sprinkler Systems) 2020 is the revised edition of CPWD General Specifications for Electrical Works, Part – V (Wet Riser & Sprinkler Systems) 2006.

There was a growing need to revise these Specifications due to major technological changes in the field of Wet Riser & Sprinkler Systems over a period of time and to incorporate the modifications in the National Building Code of India as well as in Indian Standards. This edition incorporates the relevant provisions of National Building Code of India- 2016 and latest Indian Standards, namely, IS:13039:2014 (External Hydrant Systems- Provision and Maintenance-Code of Practice) and IS:15105 (Design, Installation and Maintenance of Fixed Automatic Sprinkler Fire Extinguishing Systems–Code of Practice(First Revision). Accordingly, changes have been effected in this revision.

Almost all the Chapters and Appendices have been modified to align them with the National Building Code of India-2016, IS: 13039:2014 and IS:15105 in this edition. Annexure-A has been revised in accordance with NBC-2016. In addition, an alternate provision of providing Stainless Steel Pipes and fittings has been introduced in this edition for pipe work of Automatic Sprinkler System inside the building, particularly where replacement of pipes is not easy like areas above false ceiling etc., subject to the condition that these pipes with associated fittings are suitable to safely withstand the system test pressures. Also, provision of Retrofitted emission control equipment having a minimum specified PM-capturing efficiency of at

least 70% has been kept for Diesel Pumps as recommended by National Clean Air Program-2019 launched by Ministry of Environment, Forest and Climate Change. Similarly, inclusion of Holiday Testing for wrapping and coating of Underground M S Pipe has been made. Compliance to Public Procurement (Preference to Make in India) Order (PPP-MII Order)-2017 as amended, has been emphasized. Installation of negative suction arrangement and submersible pumps has been dispensed with in line with NBC-2016/IS: 13039. Two new Appendices have been added. Figures 1, 2, 3, 4, 12 and 14 have been updated and Figure 6 has been newly added.

I am grateful to Shri Vinit Kumar Jayaswal, Director General, CPWD for reposing trust in me to undertake this arduous task in a short period. My acknowledgements are also due to Shri Anant Kumar, ADG (Tech.) who has facilitated in this task amply. I express my deep appreciation to Shri Chaitanya Kumar Varma, Chief Engineer(E) CSQ and Shri Dhirender Kumar Tulani, Superintending Engineer(E) TAS for drafting this publication within the given time frame.

Further, I acknowledge the efforts put in by Shri Ashwani Kumar Sharma, AE(E) TAS (Retd.) for his dedicated contribution just before his retirement, Sh. Jagdish Kumar, AE(E) TAS, Shri K. Madhu, AE(E) TAS and Sh. Vijender Kumar, Chief Estimator(E).

Errors or Omissions and suggestions for improvements, if any, may be brought to the notice of SE (E) TAS, Office of CE (E) CSQ, CPWD, Nirman Bhawan, New Delhi.



Place: Chandigarh
Date: September, 2020

(Sudhir Kumar Chawla)
Director General (In-Situ), CPWD
Chairman, Specifications Committee

MEMBERS OF SPECIFICATION COMMITTEE FOR E&M WORKS

1.	Sh. Sudhir Kumar Chawla, DG (In-Situ)	Chairman
2.	JS & CVO or his representative	Member
3.	Sh. A. K. Ahuja, ADG, PWD, Delhi	Member
4.	Sh. Satish Chandra Bhardwaj, ADG(RD)	Member
5.	Sh. C. K. Varma, CE (E) CSQ	Member
6.	Chief Technical Examiner or his representative	Member
7.	Sh. Shahabuddin Ahmad, CE (E), BFLZ	Member
8.	Sh. Ujjwal Mitra, CE, NDZ-III	Member
9.	Sh. M. K. Mallick, CE CSQ (C)	Member
10.	Sh. Harish Kumar, DDG (W)	Member
11.	Sh. Vikas Gupta, CE (E)PEWZ	Member
12.	Sh. Vimal Kumar, CE (W cum TLQA)	Special Invitee
13.	Sh. Vikas Rana, CE (NDZ-I)	Member
14.	Sh. Awadhesh Kumar, CE (E) Trg.	Member
15.	Chief Architect (DR)	Member
16.	Sh. Ali Shamsheer, Director Finance	Member
17.	Sh. Rajeev Sao, SE(E)	Special Invitee
18.	Sh. Dhirender Kumar Tulani, SE (E) TAS	Member Secretary

REFERENCES OF AMENDMENTS

S.No.	Reference under which Issued	Chapter No.	Item No.	Page

CONTENTS

S.No.	Description	Page No.
1	Chapter 1 General	1-9
2	Chapter 2 System and System Requirements	10-19
3	Chapter 3 Architectural and Structural Requirements	20-23
4	Chapter 4 Planning, Designing and Coordination	24-30
5	Chapter 5 Fire Pumps	31-33
6	Chapter 6 Diesel Engine for Fire Pumps	34-38
7	Chapter 7 Pipe Work	39-46
8	Chapter 8 Firefighting Accessories	47-50
9	Chapter 9 Automatic Sprinkler System	51-67
10	Chapter 10 Electrical works	68-73
11	Chapter 11 Installation, Testing and Commissioning	74-78
12	Appendix -A Minimum Requirements for Firefighting Installations	79-92
13	Appendix -B Terminology	93-95
14	Appendix -C Maintenance and Operation of Wet Riser System	96-99
15	Appendix -D Maintenance of Automatic Sprinkler System	100-101
16	Appendix-E List of Relevant Indian Standards	102-103
17	Appendix-F Table 17 Plate flanges for welding	104
18	Figures (1 to 15)	105-119
19	Appendix- G Extracts from NBC-2016, Vol.1, Part-4	120-122
20	Appendix-H Extracts from IS-13039, 2014	123-124

CHAPTER-1

GENERAL

1.1 INTRODUCTION

1.1.1 Scope

1.1.1.1 These specifications cover water based fixed firefighting installations described in Para 2.2.

1.1.2 Related Documents

These General Specifications shall be read in conjunction with the general conditions of contract, tender specifications, schedule of work, drawings and other documents connected with the work. In the event of any discrepancy between these specifications and general conditions of contract and tender specifications, the latter shall override the former.

1.1.3 Terminology

The definition of terms used in these specifications shall be in accordance with relevant IS. Some of the commonly used terms are defined in Appendix-B.

1.1.4 Site Information

The tenderer should, in his own interest, visit the site and familiarize himself with the site conditions before tendering. For any clarification, tenderer may discuss with the Engineer-in-Charge.

1.2 CONFORMITY WITH STATUTORY ACTS, RULES, ORDERS, STANDARDS AND CODES

(i) All components and their installation shall conform to relevant Indian Standard Specifications, wherever existing, amended to date. A list of such standards is appended in Appendix-E.

(ii) As per Public Procurement (Preference to Make in India) Order (PPP-MII Order), inclusion of foreign standards/certification in tenders, thereby excluding local manufacturers, is violative of the Order.

Therefore, utmost care shall be taken to stipulate Indian Standards/certifications instead of foreign standards/certifications for various products/materials in the tender documents.

In all cases, the PPP-MII Order 2017 as amended shall be strictly complied.

(iii) All electrical works shall be carried out in accordance with the provisions of Indian Electricity Act, 2003 and Electricity Authority (Measures Relating to Safety and Electric Supply) Regulations, 2010, NEC 2011 amended to date. They shall

also conform to CPWD General Specifications for Electrical Works, Part-I (Internal)-2013, Part-II (External)- 1994, Part IV (Sub-station)-2013 and Part-VII (D G Sets)-2013 amended to date.

1.3 SAFETY CODES AND LABOUR REGULATIONS

- (i) In respect of all labour employed directly or indirectly on the work for the performance of the firefighting contractor's part of work, the contractor at his own expense, will arrange for the safety provisions as per the statutory provisions including "Safety, Health and Environment Handbook 2019" published by CPWD, B.I.S recommendations, Factory Act, Workman's Compensation Act, CPWD Code and instructions issued from time to time. Failure to provide such safety requirements would make the tenderer liable for penalty to be decided by Engineer-in-charge. In addition, the Engineer-in-charge, shall be at liberty to make arrangements and provide facilities as aforesaid and recover the cost incurred thereon from the contractor.
- (ii) The contractor shall provide necessary barriers, warning signals and other safety measures while laying pipelines, cables etc. or wherever necessary so as to avoid accident. He shall also indemnify CPWD against claims for compensation arising out of negligence in this respect. Contractor shall be liable, in accordance with the Indian Law and Regulations, for any accident occurring due to any cause. The department shall not be responsible for any accident occurred or damage incurred or claims arising therefrom during the execution of work. The contractor shall also provide all insurance including third party insurance as may be necessary to cover the risk. No extra payment would be made to the contractor due to the above provisions thereof.

1.4 WORKS TO BE ARRANGED BY THE DEPARTMENT

Unless otherwise specified in the tender documents, the following works shall be arranged by the Department:

- (i) Space for accommodating all the equipment and components involved in the work,
- (ii) Power supply, Water supply and Drain points as per para 1.6,
- (iii) Masonry ducts within and outside the building for carrying pipe lines and cables wherever specified.
- (iv) Under ground and terrace tanks.

In case of composite contracts, having Firefighting work as one of the works, these arrangements shall be made by the agency/ contractor only.

1.5 WORKS TO BE DONE BY THE CONTRACTOR

Unless otherwise mentioned in the tender documents, the following works shall be done by the contractor and therefore, their cost shall be deemed to be included in the tendered cost- whether specifically indicated in the Schedule of Work or not: -

- (i) Foundations for equipment including foundation bolts and vibration isolation spring/pads,
- (ii) Suspenders, brackets and floor/wall supports for suspending/supporting pipes.
- (iii) Suspenders and/or cable trays for laying the cables,
- (iv) Excavation and refilling of trenches in soil wherever the pipes are to be laid directly in ground, including necessary base treatment and supports.
- (v) Sealing of all floor slab/wall openings provided by the Department or made by the contractor for pipes and cables, from fire safety point of view, after laying of the same.
- (vi) Painting of all exposed metal surfaces of equipment and components with appropriate colour as per para 1.13.
- (vii) Making openings in the walls/floors/slabs or modification in the existing openings wherever provided for carrying pipe line, cables etc.
- (viii) All electrical works including cable/wires, earthing etc. beyond power supply made available by the department.
- (ix) Making good all damages caused to the structure during installation and restoring the same to their original finish.
- (x) Approval from local fire authorities as may be required as per local bye-laws. (The contractor's responsibility shall be limited to the work executed by him.)

1.6 POWER SUPPLY, WATER SUPPLY AND DRAINAGE

1.6.1 Power Supply

- (i) Unless otherwise specified, 3 phase, 415 volts, 50 Hz, AC power supply (5 kW) shall be provided by the department free of charge to the contractor at one point for installation at site. Termination switchgear however, shall be provided by the contractor. Further extension, if required, shall be carried out by the contractor.
- (ii)
 - (a) The power supply for testing and commissioning of the complete installation shall be made available by the Department free of charge to the contractor. For this purpose, the power supply shall be given at the main incomer unit of the electrical panel to be provided by the contractor. The termination of this feeder in the main incomer unit shall be the responsibility of the contractor and nothing extra shall be paid on this account.
 - (b) Unless otherwise specified in the contract, further power distribution to the various equipment shall be done by the contractor.

- (iii) Where the power supply has to be arranged by the Department at more than one point as per the terms of the contract, the termination of all such power feeders in the incomer of respective control panels to be provided by the contactor shall be the responsibility of the contractor and nothing extra shall be paid on this account.
- (iv) The contractor shall use the power supply only for the bonafide use of the work. No major fabrication work shall be done at site. Power shall be used only for welding/cutting works. The power supply shall be disconnected in case of such default and the contractor shall then have to arrange the required power supply at his cost.
- (v) In case of composite contracts, having Firefighting work as one of the works, these arrangements shall be made by the agency/ contractor only.

1.6.2 Water Supply

Water supply shall be made available to the contractor by the Department free of charge at only one point for installation. Further extension if required shall be done by the contractor at his cost.

In case of composite contracts, having Firefighting work as one of the works, this arrangement shall be made by the agency/ contractor only.

1.6.3 Drainage

- (i) Drain traps in pump room shall be arranged by the department.
- (ii) Piping Connections from the equipment to the drain trap shall be done by the contractor. These items of work shall be measured and paid as per contract.

In case of composite contracts, having Firefighting work as one of the works, this arrangement shall be made by the agency/ contractor only.

1.7 MACHINERY FOR ERECTION

All tools and tackles required for unloading / handling of equipment and materials at site, their assembly, erection, testing and commissioning shall be the responsibility of the contractor.

1.8 COMPLETENESS OF THE TENDER, SUBMISSION OF PROGRAMME, APPROVAL OF DRAWINGS AND COMMENCEMENT OF WORK

- (i) *Completeness of the tender:-*

All sundry equipment, fittings, assemblies, accessories, hardware items, foundation bolts, supports, termination lugs for electrical connections, cable glands, junction boxes and all other items which are useful and necessary for proper assembly and efficient working of the various equipment and components of the work shall be deemed to have been included in the tender, irrespective of the fact whether such items are specifically mentioned in the

tender or not.

(ii) *Submission of programme:-*

Within fifteen days from the date of receipt of the letter of award, the successful tenderer shall submit his programme for submission of drawings, supply of equipment, installation, testing, commissioning and handing over of the installation to the Engineer-in-Charge. This programme shall be framed keeping in view the building progress and the Milestones fixed in Schedule 'F' Clause-5 of General Conditions of Contract. Items like piping etc. that directly affect the building progress shall be given priority. Hose pipes, branch pipes, first aid hose reel pipes shall be supplied just before commissioning the system.

(iii) *Submission of Drawings:-*

The contractor shall submit the drawings to the Engineer-in-Charge as per para 1.17.2 for approval before start of work.

(iv) *Commencement of work:-*

The contractor shall commence work as soon as the drawings submitted by him are approved either in full or in part as the case may be.

1.9 DISPATCH OF MATERIALS TO SITE AND THEIR SAFE CUSTODY

The contractor shall dispatch materials to site in consultation with the Engineer-in-Charge. Suitable lockable storage accommodation shall be made available free of charge temporarily. Watch and ward however, shall be the responsibility of contractor. Programme of dispatch of material shall be framed keeping in view the building progress. Safe custody of all machinery and equipment supplied by the contractor shall be the responsibility of the contractor till final taking over by the department.

1.10 CO-ORDINATION WITH OTHER AGENCIES

The contractor shall co-ordinate with all other agencies involved at the site of work so that the work of other agencies is not hampered due to delay in his work. Piping, cabling or any other work, which directly affect the progress of work of other agencies, shall be given priority.

1.11 QUALITY OF MATERIALS AND WORKMANSHIP

- (i) The components of the installation shall be of such design so as to satisfactorily function under all conditions of operation.
- (ii) The entire work of manufacture/fabrication, assembly and installation shall conform to sound engineering practice.
- (iii) All equipment and materials to be used in work shall be manufactured in factories of good repute having excellent track record of quality manufacturing, performance and proper after sales service.

1.12 CARE OF THE BUILDING

Care shall be taken by the contractor during execution of the work to avoid damage to the building. He shall be responsible for repairing all such damages and restoring the same to the original finish at his cost. He shall also remove all unwanted and waste materials arising out of the installation from the site of work from time to time.

1.13 COLOUR SCHEME FOR THE EQUIPMENT AND COMPONENTS

1.13.1 The entire metal work above ground level shall be painted with red color shade No. 536 of IS:5 .

1.13.2 Pump, motor and engine shall be painted with red color shade No. 536 of IS:5

1.14 INSPECTION AND TESTING

1.14.1 Initial Inspection and testing

- (i) Initial inspection of materials and equipment at manufacturer's works may be done by the Engineer-in-Charge or his representative. For item/ equipment requiring initial inspection at manufacturer's works, the contractor will intimate the date of testing of equipment at the manufacturer's works before dispatch. The contractor shall give sufficient advance notice regarding the dates proposed for such tests to the department's representative(s) to facilitate his presence during testing. The Engineer-in-charge at his discretion may witness such testing. Equipment will be inspected at the manufacturer/ authorized dealer's premises, before dispatch to the site by the contractor.
- (ii) The department also reserves the right to inspect the fabrication job at factory and the successful tenderer has to make arrangements for the same.
- (iii) The materials duly inspected by Engineer-in-Charge or his authorized representative shall be dispatched to site by the contractor.
- (iv) No additional payment shall be made to the contractor for initial inspection/testing at the manufacturer's works by the representative of the Engineer-in-Charge. However, the department will bear the expenses of its representative deputed for carrying out initial inspection/testing.

1.14.2 Final Inspection and Testing

Final Inspection and testing will be done by the Engineer-in-Charge or his representative as per details indicated in Chapter-11.

The installation will be offered for inspection of local bodies (Chief Fire Officer). The contractor or his representative shall attend such inspection of the Chief Fire Officer, extend all test facilities as are considered necessary, rectify and comply with all observations of the Chief Fire Officer which are part of the agreement and arrange for obtaining necessary clearance certificate in favour of the department. In case the contractor fails to attend the inspection and make desired facilities available during inspection, the department reserves the right to provide the same at the risk and cost of the contractor and impose penalty for the same. The installation will be accepted by the department only after receiving clearance from Chief Fire Officer for the work executed by the contractor under the agreement.

1.14.3 Safety Measures

All equipment shall incorporate suitable safety provisions to ensure safety of the operating personnel at all times. The initial and final inspection reports shall bring out explicitly the safety provisions incorporated in each equipment.

1.15 GUARANTEE

- (i) The contractor shall guarantee the complete system to provide the specified flow and pressure under all conditions at outlets.
- (ii) All equipment shall be guaranteed for a period of 12 months from the date of acceptance and taking over of the installation by the Department against unsatisfactory performance and/or breakdown due to defective design, material, manufacture, workmanship or installation. The equipment or component or any part thereof so found defective during the guarantee period shall be repaired or replaced free of cost to the satisfaction of the Engineer-in-charge. In case, it is felt by the department that undue delay is being caused by the contractor in doing this, the same will be got done by the department at the risk and cost of the contractor. The decision of Engineer-in-charge in this regard shall be final.

1.16 PAYMENT TERMS

1.16.1 The following percentage of contract rates shall be payable against the stages of work shown herein:

Stage of work	Machinery and Equipment (Pumps and Electrical Panel)	All other items
I After initial inspection (wherever specified) and delivery at site in good condition on pro-rata basis	80%	70%
II On completion of installation on pro-rata basis	10 %	20 %

III	On testing, commissioning and handing over.	10 %	10 %
-----	---	------	------

1.17 TENDER DRAWINGS, DRAWINGS FOR APPROVAL AND COMPLETION DRAWINGS

1.17.1 Tender Drawings

The drawings appended with the tender documents are intended to show the areas allotted for various equipment, tentative pipe routes. The equipment offered shall be suitable for installation in the spaces shown in these drawings.

1.17.2 Drawings for approval on award of the work

The contractor shall prepare and submit following drawings and get them approved from the Engineer-in-charge before the start of the work. The approval of drawings however does not absolve the contractor of his responsibility to supply the equipment/materials as per agreement. In case of any contradiction between the approved drawings and agreement the decision of the Engineer-in-Charge shall be final and binding on the contractor.

- (a) Layout drawings of the equipment to be installed in pump room and terrace
- (b) Drawings showing the details of erection of entire equipment including their foundations
- (c) Plumbing drawings showing the layout of entire piping, diameter and length of pipes, hydrant, air vessel, valves and isometric drawings showing connections to various equipment
- (d) Sprinkler drawing indicating layout and sizes of pipe, location of valves, sprinklers etc.
- (e) Electrical wiring diagrams for all electrical equipment and controls including the sizes and capacities of the various cables and equipment
- (f) Dimensioned drawings of all electrical and control panels
- (g) Drawings showing details of supports for pipes, cable trays etc.
- (h) Any other drawing(s) relevant to the work

1.17.3 Completion Drawings

Three sets of the following laminated drawings shall be submitted by the contractor while handing over the installation to the Department. Out of this one of the sets shall be laminated on a hard base for display in the fire control room. In addition, one set will be given on compact disc.

- (a) Installation drawings giving complete details of all the equipment, including their foundations,
- (b) Plumbing layout drawings giving sizes and lengths of all the pipes and the

sizes and locations of all types of valves, and including isometric drawings for the entire piping including the pipe connections to the various equipment,

- (c) Line diagram and layout of all electrical control panels giving switchgear ratings and their disposition, cable feeder sizes and their layout,
- (d) Control wiring drawings with all control components and sequence of operations to explain the operation of control circuits.

1.18 DOCUMENTS TO BE FURNISHED ON COMPLETION OF INSTALLATION

Three sets of the following documents shall be furnished to the department by the contractor on completion of work:-

- (a) Completion drawings as per Para 1.17.3
- (b) 3 sets of manufacturer's technical catalogues of all equipment and accessories.
- (c) Operation and maintenance manual of all major equipment, detailing all adjustments, operation and maintenance procedure.
- (d) Name plate details of all equipment.

CHAPTER-2

SYSTEM AND SYSTEM REQUIREMENTS

2.1 INTRODUCTION

Fire safety in buildings has become very important consideration in construction and maintenance. A normal office building has fire load in the form of large quantity of papers and furnishing. Buildings like Hospitals, Laboratories, Auditoriums, Libraries, Museums etc. require fire safety provisions by virtue of their type of occupancy and importance irrespective of their height.

The aim of fire safety measure is to provide protection to life of occupants and property in the event of fire in the building. National Building Code of India-2016, Vol-1, Part-4 deals in detailed measures to be adopted for fire safety in buildings. The measures depend upon the occupancy, use, height and area of the building.

The broad classification of various type of occupancies into different Groups in accordance with NBC-2016, Vol-1, Part-4 is as under: -

1. Group-A Residential
2. Group-B Educational
3. Group-C Institutional
4. Group-D Assembly
5. Group-E Business
6. Group-F Mercantile
7. Group-G Industrial
8. Group-H Hazardous

For further details of classifications, NBC-2016 is to be referred.

Besides various mediums of fighting fire, water is the cheapest and the most easily available for this purpose. Water based fixed firefighting installations are most commonly provided in buildings.

The design and installation of a firefighting system is of utmost importance. The firefighting installation on completion will have to be got cleared from the local firefighting authorities (Fire Service) for its efficacy, suitability and usability by the Fire Service in the event of a fire.

Accordingly, such system shall be executed on turnkey basis to ensure proper quality of material and zero leakage system apart from use of equipment and other accessories. All the components shall be integrated to ensure proper

performance at the time of fire.

2.2 FIREFIGHTING SYSTEM:

2.2.1 Following types of water based fixed firefighting installations are normally provided in buildings:

- (i) Wet Riser
- (ii) Down Comer
- (iii) Wet Riser cum Down Comer
- (iv) Automatic Sprinkler

2.2.2 In all the above systems, lines are laid in and/or around the building and permanently charged with water from a pressurized supply.

In a building, any one system or a combination shall be provided as specified in Table-7 of National Building Code of India-2016, Vol-1, Part-4 as amended up to date, depending upon the occupancy, use and height for protection.

The effective capacity of Under-ground static & Terrace Water Storage Tanks and capacity of Fire Pumps etc. shall also be as specified in Table-7 of NBC-2016. The same has been reproduced as Appendix-A of this document. The effective capacity of the reservoir shall be measured above the top of the pump casing (flooded suction).

Note: For additional occupancy wise requirements of various Groups mentioned in Para 2.1 above, the provisions contained in *Clause 6 of NBC 2016, Vol-1, Part-4 shall be referred to.*

2.2.3 Municipal Regulation of the city shall also be taken in to consideration while selecting and designing firefighting system for a building.

2.3 SYSTEM COMPONENTS

Besides architectural and building provisions such as underground tank, pump houses, terrace tank, shafts for installation of internal hydrants, etc. firefighting systems shall generally comprise supply, installation, testing and commissioning of components as detailed in Table 2.1. Typical arrangement of installations have been indicated in Figures 1 to 6.

2.4 SYSTEM ENGINEERING:

The capacities and sizes of various components described above will depend upon the type and height of the building. Specifications of various components have been described in succeeding chapters. Following factors shall be taken in to consideration while designing various components.

2.4.1 Wet Riser cum Down Comer:-

2.4.1.1 Pressure at hydraulically remote hydrant and at the highest hydrant shall not be less than 3.5 kgf/cm². The pressure at the hydrants shall however not exceed 7 kgf/cm².

2.4.1.2 The pipe line will be designed in such a way that it should be possible to get discharge at any location. Design parameters shall be as under:-

- (i) Maximum flow velocity : 2.5 mps
- (ii) Maximum Friction : 5 m per 100 m run

However, the size of wet riser shall be as given in Table 4.1 under Para 4.5.4 (ii).

2.4.1.3 Main Fire Pumps (Both electrical as well as diesel) shall be selected for:

- (i) Discharge : 1620 lpm/2280 lpm/2850 lpm
(To be selected from Appendix-A)
- (ii) Head : 35 m + Height of terrace level
hydrant above pump level + 6% of
the maximum length of pipe from
pump discharge to any hydrant at
terrace level

2.4.1.4 Terrace pump shall be selected for:

- (i) Discharge : 450 lpm/900 lpm
(To be selected from Appendix- A)
- (ii) Head : 20 m+ 6% of the maximum length
of pipe from terrace pump to any
hydrant at terrace level

2.4.1.5 Pressurization pump (Jockey Pump) shall be selected for :

- (i) Discharge : 180 lpm
- (ii) Head : 35 m + height of terrace level
hydrant above pump level

2.4.1.6 No. of Risers:- Number of risers will be decided to fulfill the following conditions:-

- (i) No corner of the building is farther than 30 m from nearest riser.
- (ii) Horizontal distance between two risers shall not be more than 50 m.
- (iii) Normally one riser is provided for every 1000 sq.m of plinth area or part thereof.

However, the number of risers can be suitably increased to meet the given situation.

TABLE 2.1
VARIOUS COMPONENTS OF FIREFIGHTING INSTALLATIONS

S. No.	System component	Wet Riser	Down Comer	Wet Riser cum Down Comer	Automatic Sprinkler and Wet Riser cum Down Comer
(i)	Electric Motor Driven Fire Pump	Y	N	Y	Y
(ii)	Diesel Engine Driven Fire Pump (as stand by)	Y	N	Y	Y
(iii)	Pressurization Pump (Jockey Pump)	Y	N	Y	Y
(iv)	Terrace Pump	N	Y	Y	Y
(v)	Vertical risers in the building.	Y	Y	Y	Y
(vi)	Pipe network inside the building throughout the area to be protected with Sprinklers	N	N	N	Y
(vii)	External pipe line around the building.	Y	N	Y	Y
(viii)	Internal Hydrant	Y	Y	Y	Y
(ix)	Yard Hydrant (External Hydrants)	Y	N	Y	Y
(x)	First-aid hose reel.	Y	Y	Y	Y
(xi)	Hose Pipe and Branch Pipe.	Y	Y	Y	Y
(xii)	Air Vessels.	Y	Y	Y	Y
(xiii)	Fire Service Connections.	Y	N	Y	Y
(xiv)	Fire Service Inlet.	Y	Y	Y	Y
(xv)	Control components like pressure switches, flow switches level indicator, alarm etc.	Y	Y	Y	Y
(xvi)	Electrical Power and Control Panel with cable and earthing etc.	Y	Y	Y	Y
(xvii)	Pipe line accessories like Butterfly/ Sluice Valve, Non-Return Valve etc.	Y	Y	Y	Y

'Y' Stands for: to be provided.

'N' Stands for: not to be provided.

2.4.1.7 **Internal Hydrant:** Every riser will be provided with the following at every floor including terrace and basement over and above sprinkler system.

- (i) Single headed outlet -2 Nos.
- (ii) First Aid Hose Reel -1 No.
[Length of pipe shall be such that nozzle of the hose can be taken into every room and within 6 m of any part of the rooms keeping in view layout and obstruction.]
- (iii) Hose Pipe 63 mm dia, 15 m long with male and female coupling at ends. -2 Nos.
- (iv) Branch pipe 63 mm dia with 20 mm nominal internal diameter nozzle and suitable for instantaneous connection. -1 No.

2.4.1.8 **Yard Hydrant (External Hydrant)**

2.4.1.8.1 For fighting fire from outside the building, yard hydrants are provided around the building and in the closed court yard. For connecting yard hydrants a ring of pipe shall be laid underground around the building at a minimum distance of 2 m from the face of the building. All internal risers shall be connected with this ring.

Yard hydrants shall be located at a minimum distance of 2 m but not more than 15 m from the building face. The yard hydrants shall be easily accessible and should normally be provided near boundary wall/along road. While locating yard hydrants it should be ensured that same do not become hindrance in vehicular movement or entrance to the building. Yard hydrants, should be located around the building in such a way that it should be possible to fight fire on any face of the building from the nearest hydrant. At least one hydrant post shall be provided for every 45 m.

2.4.1.8.2 Fire Hydrants shall be of stand post type conforming to IS 908. All Yard hydrant outlets shall be situated 1 m above ground level.

2.4.1.8.3 The stand posts shall be 80 mm in diameter for single headed hydrants. The stand posts shall be painted 'fire red' as per Para 1.13. Mild steel stand post may be accepted even in cases where underground mains are of cast iron, using flanged joints.

2.4.1.8.4 Only Oblique hydrants conforming to IS 5290 with outlets angled towards ground shall be used. The hydrant couplings shall be of the instantaneous spring-lock (female) type of 63 mm diameter and valves shall be of the screw down type.

2.4.1.8.5 Suitable pressure reducing devices shall be provided for yard as well as internal hydrants where the pressure exceeds 7 kgf/cm², considering the safety of operators.

2.4.1.8.6 All hydrants should be serially numbered.

2.4.1.8.7 Yard hydrant will include the following accessories

- (i) Connection from ring main with 80 mm dia MS pipe
- (ii) 63 mm dia single head landing valve - 1 No.
- (iii) Butterfly/slucice valve 80 mm dia - 1 No.
- (iv) Hose pipe 63 mm dia 15 m long
with male and female coupling at ends - 2 Nos.
- (v) Branch pipe 63 mm dia with 20 mm nominal
internal diameter nozzle, suitable for
instantaneous connection - 1 No.

All above components shall be housed in a suitable size MS cabinet made from 2 mm thick sheet with glass panel on front. The cabinet shall be painted red as per Para 1.13.

(Note:- In case hose pipes and branch pipes are likely to be stolen from yard hydrants, the same may be kept in a central place i.e. fire control room/ fire pump room.)

2.4.1.9 **Fire Service inlet** :- In order to facilitate feeding of water in the system by fire service, a 2/3 way 63 mm diameter collecting head shall be provided and connected with each riser/down comer and the ring main with non-return valve and butterfly/slucice valve. This should be located at a place where fire brigade tender can reach.

2.4.1.10 **Fire Service connection**: It is for feeding water to underground storage tank by fire tenders. The static water storage tank shall be provided with a fire brigade collecting head with 4 number 63 mm diameter instantaneous male inlets arranged in a valve box at a suitable point at street level. If tank is not approachable for the fire engines, the fire brigade collecting head shall be connected to the static tank by a suitable fixed galvanized iron pipe not less than 150 mm in diameter to discharge water into the tank when required.

2.4.1.11 **Fire Brigade draw out collecting head:** Each of the static water storage tanks shall also be provided with a fire brigade draw out collecting head with 63 mm diameter instantaneous male draw out arranged in a valve box at a suitable point at street level. This draw out shall be connected to galvanized iron pipe of 100 mm diameter with foot valve arrangement in the tank.

2.4.1.12 **Air Vessel:** - To counteract the water hammer effect, air vessel shall be provided at the top of each riser.

2.4.1.13 **Orifice Plate:** - Suitable pressure reducing devices shall be provided for yard as well as internal hydrants to control pressure to desired limit especially at lower level hydrants. (*refer Para 2.4.1.1 & 2.4.1.8.5 above*)

2.4.1.14 **Alarm for Wet Riser System:** - To indicate the flow of water in the system, turbine type alarm shall be provided at a prominent place outside the pump house in the main line before any connection is taken. The alarm will indicate the healthiness of the system and shall not be silenced till the main fire pump is in operation.

2.4.1.15 **Control system-**

2.4.1.15.1 The system shall be designed for operation automatically so that as and when water is drawn from the system through any hydrant, the pumps will operate automatically and feed water in to the system. However once a fire pump starts working, it will be stopped only manually (except jockey pump) or on account of any fault or non-availability of power supply to electrical pumps or low water level in UG/Terrace tank.

Facility shall also be provided for manual operation. A selector switch for auto/manual selection shall be provided for each pump.

2.4.1.15.2 The control system shall be designed to provide the following sequence of operation:

- i) The Pressurization Pump shall maintain pressure in the system and shall operate only on account of slow pressure loss. In case of sudden pressure loss the Pressurization Pump shall not operate. The pump shall start when the water pressure in the system falls to a pre-set value (about 0.35 kgf/cm² below normal system pressure) and shut down when the system pressure reaches the set value. Both limits shall be adjustable.
- ii) Main Electric Fire Pump shall operate on account of sudden pressure loss. So long as Main Electric Fire Pump is working, other Fire Pumps will not operate. The pump shall start when the water pressure falls to a pre-set value in the system (about 1 kgf/cm²).

- In case, Normal Electric Supply fails while the Main Electric Fire Pump is running, the DG Set for essential supply will start within 5 seconds.
- iii) The Diesel Fire Pump will start on sudden pressure loss, only in case supply to Main Electric Fire Pump is not available or within a pre-set time the Main Electric Fire Pump fails to start or fails during operation. No other pump will be working when Diesel Engine Fire Pump is in operation. Audio-Visual Alarm shall be available to indicate failure of Main Electric Fire Pump.
 - iv) A three attempts starting facility will be provided for diesel pump.
 - v) If within a pre-set time, the standby pump also fails to start or fails to develop pressure, the standby pump shall also be shut down and locked out. An audio visual alarm indication shall be given at the control panel.
 - vi) The Terrace Pumps will start on sudden loss of pressure only when both the Fire Pumps have either failed to start or exhausted water.
 - vii) In case sprinkler pump is also provided :
 - a) Sprinkler pump will start on pressure loss (about 1 kgf/cm²) in the sprinkler header.
 - b) If sprinkler pump does not start in preset time or fails during operation, the main electric fire pump shall start and feed water to sprinkler system.
 - c) Diesel pump will start and feed water only in case supply to main electric pump is not available or within a preset time the main electric pump fails to start or fails during operation. No other pump will be working when diesel pump is in operation. Audio-visual alarm shall be available to indicate failure of both sprinkler and main electric pump.
 - viii) Only one pump will be working at a time. In manual mode more than one pump can be started.
 - ix) Water level in UG and terrace tanks shall be monitored and in case of low water level, pumps connected with the tank shall not operate (even on manual mode) or stop operation as the case may be. An audio-visual alarm shall be given at the control panel.

2.4.2 **Wet Riser:-** In wet riser system all components described in 2.4.1 shall be provided except terrace pump. Terrace tank shall not be required. Wet Riser shall be interconnected at terrace level to form a ring and cut-off shall be provided for each connection to enable repair/maintenance without affecting rest of the system.

2.4.3 **Down Comer:-** In down comer, underground tank, fire pumps at ground level, ring main and yard hydrant will not be provided. Except these items, all other items described in 2.4.1 shall be provided. Following points are also to be taken in to consideration:

2.4.3.1 A minimum of two terrace pumps (electrical) shall be provided. One pump

shall act as standby.

2.4.3.2 **Down comer Pipes:** - Consideration of Para 2.4.1.6 shall apply.

2.4.3.3 All down comer pipes shall be inter connected at the terrace level. In case terraces are not interconnected, all building will be treated as individual buildings.

2.4.3.4 Fire service inlet shall be provided with each Riser/down comer for facilitating pumping of water from fire service tenders.

2.4.3.5 **Control system:** - The starting of terrace pump shall be automatic i.e. with the opening of any hydrant valve or hose reel on any floor, the pump will start automatically with fall in line pressure. In addition start/stop push buttons shall be provided at ground floor near internal hydrant for starting the pump manually. Where fire control room has been provided, remote operation of terrace pump may be done from fire control room in place of near internal hydrant. The control panel for terrace pumps shall be provided near the pumps in a suitable enclosure to avoid unauthorized operation.

2.4.4 Automatic Sprinkler :-

2.4.4.1 In addition to all provisions of Wet riser and Down comer system described in Para 2.4.1, in automatic sprinkler system, water lines of various size are laid throughout the area to be protected and sprinkler heads are provided at regular interval so that water from sprinkler heads cover the entire area under fire.

2.4.4.2 Sprinkler has two functions to perform i.e. to detect fire and then to provide adequate distribution of water to control or extinguish it. Sprinkler heads operate at pre- determined temperature to discharge water over the affected area below. Only those sprinkler heads operate which are in the vicinity of fire i.e. those which become sufficiently heated.

2.4.4.3 Lines for sprinklers shall be separate or common with wet riser system depending upon requirements mentioned in Appendix-A.

2.4.4.4 The area to be protected by sprinkler is divided in to various zones. For detecting operation of sprinkler in a zone, flow switches are provided which are wired to an annunciation panel installed in the Fire Control Room. In the event of operation of sprinkler(s) in an affected area, the annunciation panel

will give audio-visual alarm and indicate the affected zone. This arrangement will be independent of fire alarm system.

2.4.4.5 The sprinkler shall be installed only where there is no danger of freezing of water in the pipes at any time.

2.4.4.6 Details of sprinkler installations have been given in separate Chapter 9.

CHAPTER-3

ARCHITECTURAL AND STRUCTURAL REQUIREMENTS

3.1 SCOPE

This chapter outlines the general guidelines for planning the space requirements, equipment location, floor loading and other structural requirements for firefighting systems.

3.2 Following provisions/spaces are required for firefighting system:

3.2.1 **Static Water Storage Tanks:** - In order to ensure satisfactory supply of water for the pumps of firefighting, static water storage tanks exclusively for the purpose of firefighting shall be provided. The tank shall be provided both underground and/or at terrace. Reservoir for Wet Riser System shall be lined. The effective capacities of the reservoir above the top of the pump casing (flooded suction) for various types of occupancies shall be as indicated in Appendix- A.

While deciding the capacities of underground and terrace tanks following points shall also be taken into consideration:

- (i) In case common pump house and underground tank are to be provided for more than one building in a campus, the capacity of UG tank shall be increased, if required in consultation with local Fire Brigade.
- (ii) Arrangement shall be made for replenishment of water from alternative source at the rate of 1000 lpm for underground tank. When this is not feasible the capacities of storage tanks (both underground and terrace tanks) shall be increased suitably in consultation with local Fire Brigade.
- (iii) Water for firefighting shall be stored in two or more interconnected compartments of equal size to facilitate cleaning and maintenance of the tanks without interrupting the water availability for firefighting.
- (iv) The underground fire water storage tank(s) shall not be more than 7 m in depth from the level having fire brigade draw-out connection, while the draw-out connection shall not be more than 5 m away from the tank wall.
Para 2.4.1.11 above may also be referred.

3.2.1.1 **Following factors are to be considered for deciding the location of underground water storage tank:**

- (i) The tank shall be by the side of road so that fire brigade personnel can draw water from the tank or discharge water into the tank. Suitable manhole shall be provided for this purpose.
- (ii) When the slab of the tank forms a part of pathway/drive way, it shall be designed to withstand the vehicular load of 45 tonnes (or as applicable) equally divided as a four-point load.

- (iii) Arrangement shall be made to replenish water by mains or alternative source.
- (iv) Suitable arrangement shall be made to prevent stagnation of water in the tank. For this purpose, the tank of domestic or other water supply may be fed from the over flow of static water storage tank to ensure water level there in. *Figure 7 may be referred to.*
- (v) The static water storage is meant for firefighting only and is not to be used for any other purpose except when the tank is to be cleaned.
- (vi) There shall be no leakage in the tank.

3.2.1.2 Following factors are to be considered for deciding the location of terrace tank:

- (i) The terrace tank should be easily accessible.
- (ii) Connection to terrace pump shall be conveniently made.
- (iii) Factors at 3.2.1.2 (iii) to (vi) shall also be considered.
- (iv) The terrace tank may be of masonry, cement concrete, M.S. or plastic depending upon relevant considerations.

3.2.2 Pump House: - For installation of firefighting pumps (Main Electrical Pump, Diesel Engine Driven and Pressurization Pump) along with Electrical & Control Panel, valves, diesel tank etc., pump house is required. Following factors are to be considered:

- (i) In order to provide positive (flooded) suction to fire pumps, the pump house shall be at a level below or equal to that of static water storage tank.
- (ii) The pump house at ground level shall be easily accessible for firefighting operations and at least 6 meters away from all surrounding buildings and overhead structures. In case, the 6m spacing of pump room from surrounding buildings is not feasible, the provisions of Para 5.1.12 of IS 13039:2014 shall be followed.
- (iii) The pump house shall not be located in the building to be protected. However, the pump house can be located in the basement subject to conditions of Clause 12.2.2 of IS 15105.
- (iv) General water supply pumps can be installed in the same pump house.
- (v) Size of the pump house shall be not less than 6.0 m (W) x 8 m (L) x 3.5 m (H). If two electrical pumps are to be provided, the length of the pump house shall be not less than 12 m. If the water supply pumps are to be installed in the same pump house, then either the width of pump house be increased by 1 m or length be increased by 2 m or suitably as is necessary.
- (vi) Suitable ramp with proper slope and/or cutout in roof shall be provided for lowering the equipment in to the pump house. Stair case with entry door at ground level and locking arrangement shall be provided.
- (vii) Ventilators at least 500 mm height shall be provided on three sides for natural light. Adequate ventilation for dissipation of heat due to operation of

motors/engine shall be provided.

- (viii) Proper water proofing shall be provided. A sump of size 0.6 m x 0.6 m x 0.3 m with 1(Working)+1(Standby) dewatering pumps shall be provided in the pump house in one corner adjacent with the tank wall. The floor slope will lead towards the sump so that water leakage can be pumped out.
- (ix) In order to ensure that there is no leakage of water in the pump house, no pipe/ cable shall cross the pump house below ground level. Suitable opening in wall above ground level shall be provided for crossing of pipes/cables.
- (x) Installation of negative suction arrangement and submersible pumps shall not be allowed.
- (xi) There shall be no beam under the floor of pump house.
- (xii) The floor of the pump house shall be designed for loading of 1500 kgf/sq.m. Foundation of pumps shall be raised over finished floor and in no case flooring or RCC walls shall be damaged while installing equipment in the pump house.
- (xiii) Pump house shall be separated by fire walls all around and doors shall be protected by fire doors (120 min rating).
- (xiv) The pump house shall be clearly marked by luminous sign.
- (xv) Typical layout of fire pump house has been shown in Figure-10.

3.2.3 Terrace Pump - Terrace pump is to be installed near terrace tank. The tank shall be at higher level to provide positive suction to the pump. No separate pump house is required for terrace pump. However suitable enclosure for protection of pump is to be provided. The pump may be located in stair case mummy if suitable space is available. The pump may be located near beam so that its load is not transferred to slab.

3.2.4 Internal Hydrant - Internal hydrants are provided to fight fire from within the building. Following factors are considered for deciding location of internal hydrant:

- (i) Internal hydrants are provided at every floor at the same location and connected with risers.
- (ii) Hydrant for firefighting shall be located in the lobby in firefighting shaft. Those hydrants planned to be provided near fire exit staircase on the floor shall be within 5 m from exit door in exit access.
- (iii) Numbers and location of risers shall be decided as per Para 2.4.1.6. Every wing of the building shall preferably be provided with independent hydrants. Hydrant shall be located in the center of the building so that one hydrant can cover area on both sides.
- (iv) A masonry enclosure on three sides of size minimum 1200 mm wide and 800 mm deep and 2100 mm height shall be provided. Cut-out of size 200 mm x 200 mm be provided in one corner in the slab for down comer/wet riser

pipe. If sprinkler installations are to be provided, additional cut out of similar size for sprinkler pipe and drain pipe as the case may be, shall be provided. Steel shutter with 1250 mm glazing on top with locking arrangement shall be provided in front of the hydrant. The shutter shall be painted red as per para 1.13. Typical arrangement has been shown in Figure-8.

- (v) Internal hydrant shall be easily accessible. A clear space of at least 1.5 m should be available in front of the internal hydrant for operation. Internal hydrant shall not be provided in a lockable room.
- (vi) Internal hydrant shall be clearly marked with the inscription of "FIRE HOSE CABINET" of letter size 75 mm in height and 12 mm in width by luminous sign. Suitable lighting arrangement shall be provided in front of the internal hydrant. The location of such cabinets shall be shown on floor plan and duly displayed in the landing of the respective fire exit staircase.

3.3 BUILDING TO BE SPRINKLER PROTECTED

The sprinkler pipes are installed throughout the area to be protected. The structure shall be designed to support sprinkler pipes and the contained water. Inbuilt drainage with slope shall be provided throughout the area so that in the event of operation of sprinkler, water is drained out without spreading to other parts of the building. Storage racks/platforms shall be sufficiently raised above floor.

It is essential to make provisions for avoiding water from Sprinkler/hydrant operation entering lifts and electrical rooms.

3.4 FIRE CONTROL ROOM

For all buildings 15 m in height or above, and apartment buildings with height 30 m and above, a fire control room (size 4 m x 4 m Approximately) shall be provided on the entrance floor of the building. One store for keeping spares for firefighting system shall also be provided adjacent with the fire control room.

CHAPTER-4

PLANNING, DESIGNING AND COORDINATION

4.1 INTRODUCTION

Planning of firefighting system is to be done right at the stage when the building plans are prepared by the Architect. Subsequently during preparation of working drawings, all architectural and structural provisions described in Chapter 3 are also to be kept in the building plans.

Careful planning from the initial stage itself will avoid changes and problems at a later stage. This chapter covers aspects of planning, designing and coordination of firefighting system.

4.2 SCHEME

The provision of firefighting installation depends upon building use, height, floor area etc. Considering these factors, the system or a combination of systems which will be required to be adopted should be finally selected in accordance with National Building Code and regulations of local fire authorities, if applicable.

4.3 APPROVAL OF LOCAL BODIES

In the building plans which are submitted to local bodies for approval, details of firefighting system proposed in the building are also indicated. Local bodies normally refer the same to Chief Fire Officer and recommendations of Chief Fire Officer are conveyed to the officer who submitted the plans. The proposed system should incorporate the recommendation of Chief Fire officer.

4.4 ARCHITECTURAL PROVISION

4.4.1 For any firefighting system, underground tank and pump house are required. These may be located anywhere in the campus subject to proper approach. The pump house should preferably be near the sub-station. It will be a good practice if all building services including firefighting are located at one place in the campus.

4.4.2 In campus having more than one building to be protected, it is not required to have individual system for every building. A number of building in the campus can be protected by common fire pumps. However yard hydrants/internal hydrants and terrace pump shall be provided in each building. When the buildings are close by, the yard hydrants can be located in such a way that one yard hydrant cover more than one building.

- 4.4.3 In a large campus, buildings of different heights may be proposed. As per National Building Code, provision of firefighting system may not be required in building with lesser heights. Provisions of firefighting system as indicated in NBC are mandatory minimum required for any building which does not debar higher provisions. An unsafe building in a campus will become potential danger to the safety of other buildings. If firefighting system is being provided in a campus on account of one or more buildings, it is desirable to extend the facility to other buildings also where this may not be required as a mandatory provision. This will ensure safety of all the building in the campus.
- 4.4.4 The shafts for vertical risers are to be provided in the building. Their number and location be decided as per guidelines given in Chapter 2 and 3.
- 4.4.5 Location of yard hydrant shall be selected in accordance with provision of Para 2.4.1.8.
- 4.4.6 Route of pipe connection from ring main to the riser shall be selected properly. Position of tie beam or any other structural member shall be checked so that it does not come in the way of pipes.
- 4.4.7 For vertical riser pipe passage, opening of 200 mm x 200 mm shall be left in slab in the internal hydrant shaft as per Para 3.2.4(iii). The opening shall be located vertically one above the other. In buildings where sprinkler system is to be installed, additional opening of same size is to be provided within the nitch at the other corner for sprinkler pipe.
- 4.4.8 Details of internal hydrant door with glass is to be provided to concerned architect/division in advance. This may be modified for architectural considerations provided the glass height is not changed. Hydrants for firefighting and hose reels shall be located in the lobby in firefighting shaft. Those hydrants planned to be provided near fire exit staircase on the floor shall be within 5 m from exit door in exit access. Such hydrant cabinet may finish with doors to meet interior finishes with requirement of glass panel to provide visibility to the installations inside and inscribed with the word: "FIRE HOSE CABINET" of letter size 75 mm in height and 12 mm in width. Such door of the fire hose cabinet need not be fire resistant rated. The location of such cabinets shall be shown on floor plan and duly displayed in the landing of the respective fire exit staircase.
- 4.4.9 Sprinkler pipes are laid throughout the area to be protected. The route of

pipes is to be pre-decided in consultation with the Architect. For vertical pipes, shafts for risers are to be used. Layout of horizontal pipe and location of sprinkler head are to be decided keeping in view of location of fans and fitting. In case false ceiling is being provided in the area, horizontal pipes may be laid above false ceiling and only sprinkler head is provided below false ceiling. If the building is centrally air-conditioned, location of duct and air termination may be taken into account. Reflected ceiling plan shall be prepared indicating all services above false ceiling.

4.5 DESIGNING

4.5.1 Requirement of components for various firefighting systems has been given in Para - 2.3. Capacity of pumps shall be worked out in accordance with Para-2.4.1.

4.5.2 Fire pumps shall be provided with positive suction and automatic starting devices capable of sequential starting of the pumps.

4.5.3 Insertions like flexible couplings/connections, bellows, etc., in the suction and delivery piping shall be suitably planned and installed.

4.5.4 The pipe sizes shall be selected as under :-

(i) Suction and delivery pipes of pumps shall not be less than following.

Pump Discharge	Suction dia (mm)	Delivery dia (mm)
(a) 450 lpm	50	50
(b) 900 lpm	75	50
(c) 1400 lpm	100	100
(d) 2280 lpm	150	150
(e) 2850 lpm	200	150
(f) 4540 lpm	250	200

(ii) Pipe connecting pump house to ring main shall be not less than 150 mm diameter. Higher size pipe shall be selected depending upon length of pipe and friction loss. Size of Ring main and Risers shall be as given in table below:

Table 4.1

S. No. (1)	Size of the Mains/Risers (mm) (2)	Type of Building (3)	Remarks (4)
i)	100 mm with single outlet landing	a) Residential building (A): 1) Dormitories 2) Apartments 3) Hotels	- - Up to 45 m height

	valves	b) Educational buildings (B) c) Institutional buildings (C) d) Assembly buildings (D) e) Business buildings (E) f) Mercantile buildings (F) g) Industrial buildings (G)	- Up to 30 m height - Up to 45 m height - Up to 15 m height
ii)	150 mm with single outlet landing valves	a) Hotels b) Starred Hotels c) Institutional buildings (C) d) Business buildings (E) e) Industrial buildings (G) f) Storage buildings (H) g) Hazardous buildings (J)	Above 45 m height - Above 30 m height Above 45 m height Above 15 m height Up to 15 m height Up to 15 m height

- (iii) Down comer pipe size shall be of 100 mm dia.
- (iv) Where wet riser/down comers are not to be provided but hose reel and terrace tanks are to be provided, pipe of size 65 mm diameter shall be provided in between the pump and hose reel.
- (v) Fire service inlet and fire service connection shall be with pipe size not less than 150 mm diameter.
- (vi) All Tee off connections for landing valves from vertical risers and for external hydrants from ring main shall be with pipe size not less than 80 mm diameter.

4.5.5 **Selection of Material:-** Components like landing valve, hose coupling branch pipes etc. are available in three material i.e. Aluminum Alloy, Gun metal and Stainless steel. Aluminum Alloy is prone to wear and tear and weather conditions faster than other two materials. However being cheaper, Aluminum Alloy may be used in location where chances of pilferage are more. Stainless steel may be considered at location not very safe from theft. Gunmetal may be used in installations which are well protected.

4.5.6 **Hose Pipes/ Branch pipes:-** A minimum of two number of 63 mm diameter, 15 m long hose pipe with instantaneous coupling at both ends and one number branch pipe with nozzle shall be kept with every internal and external hydrant.

4.5.7 **Orifice Plate:-** The pressure in a firefighting system varies from point to point. The pressure will be maximum in the pump house and minimum at the farthest hydrant at terrace level. To reduce pressure to safe operating

pressure at every internal/external hydrant, orifice plates are provided before connection of landing valve between the flanges of landing valve and pipe flange. The size of orifice shall be calculated as per details given in Table 4.2.

TABLE 4.2
SELECTION OF ORIFICE PLATE

Pressure Loss Kgf/cm ²	Diameter of Orifice (mm)	
	Pipe Size	
	80 mm	100 mm
3.5	41.9	
3.0	43.0	
2.5	44.80	
2.0	46.40	
1.5	48.90	56.20
1.0	52.30	57.60
0.9	53.20	59.00
0.8	54.10	60.40
0.7	55.30	62.00
0.6	56.60	63.90
0.5	58.20	66.50
0.4	59.80	69.70
0.3	62.00	74.20
0.2	65.00	81.10
0.1		82.20

Other suitable means may also be used for reducing the pressure apart from orifice plates.

4.5.8 Fire pumps shall be provided with positive suction.

4.6 COORDINATION

4.6.1 *Award of Work*:- Depending upon progress of building work, the work of firefighting should be awarded well in time.

4.6.2 *Power and Water supply for Erection*: - If the department is to provide power and water for erection, the same should be made available before start of the work since without these facilities, firefighting work cannot be started.

4.6.3 The Pump house and underground tank where main equipment is to be installed should be available immediately after the work has been awarded.

- During Construction of underground tank, 2 Nos. 200 mm diameter MS -C Class pipe with flanges on both sides shall be embedded for connection with suction header of the fire pumps. In case separate sprinkler pumps are to be provided, additional pipes shall be embedded as per actual requirement. The pipe shall be extended at least 100 mm on both sides of the finished wall.
- 4.6.4** The underground tank and Pump house shall be tested for any leakage/seepage before start of the work. It shall be ensured that both tank and pump house are free from leakage/seepage.
 - 4.6.5** The work of laying of pipe for sprinklers should be taken up in coordination with the duct installation in case of building being provided with central air-conditioning, otherwise after plaster work is over and one coat of white wash has been applied.
 - 4.6.6** The sprinkler pipes should be tested area wise and capped for connection to pipes of adjoining area.
 - 4.6.7** The route of external pipe i.e. pipe from pump house and ring main should be decided in coordination with other building services. Guide lines of Chapter 2 and 4 are to be followed. It will be desirable to prepare a services drawing where all services i.e. sewage, drainage, water supply lines, UG cable, pipes for air-conditioning and firefighting are reflected.
 - 4.6.8** Riser pipes shall be installed after the riser shafts are available duly plastered.
 - 4.6.9** For laying of external pipes, excavation up to a depth of 1.25 m or more is to be carried out. This may cause hindrance in execution of other building works. External pipes shall therefore be laid in a phased manner in coordination with other agencies. The pipes shall be tested and earth filled back before excavation for next phase is taken up. Equipment for testing etc. should be available in advance before start of underground pipe laying work.
 - 4.6.10** All underground pipes are to be laid much before starting of finishing work i.e. pavement, road/ horticulture work etc. around the building.
 - 4.6.11** The work of installation of equipment in pump house should be carried out simultaneously and kept ready for connection to the pipe network.
 - 4.6.12** Before occupation, the building is to be inspected by the representative of

Chief Fire Officer and local bodies. The building will be issued N.O.C. for occupation only when all safety provisions including firefighting work are complete to the satisfaction of Chief Fire Officer. As such, firefighting work is to be completed and commissioned with temporary power supply well before other building works and services are complete.

CHAPTER-5

FIRE PUMPS

5.1 SCOPE

This chapter covers the general requirements of water pumps for main fire pump, jockey pump and terrace pump.

5.2 TYPE

Pumps conforming to IS 12469 shall be exclusively used for Firefighting purposes. The pumps shall be centrifugal type direct driven with a 3 phase, 415 V \pm 10%, 50 Hz, A.C. motor. The standby fire pump shall be driven by diesel engine. The pumps may be either of horizontal split casing (HSC) type with operating speed not exceeding 1500 rpm, or solid casing with operating speed not exceeding 3000 rpm as specified in the tender documents.

5.3 RATING

The main fire pump and terrace pump shall be suitable for continuous operation in the system. The jockey pump shall be suitable for intermittent operation to buildup pressure in the system on account of leakage. The head and discharge requirements shall be as specified in the tender documents. The head shall be suitable for the system and shall take into consideration the pressure drops across the various components in the water circuit as well as the frictional losses.

The rated discharge of Electric Driven and Diesel Engine Driven pump shall be as specified in Table given in Annexure-A. Pump shall be capable of discharging not less than 150 percent of the rated discharge at a head of not less than 65 percent of the rated head. The shut off head shall not exceed 120 percent of the rated head in the case of horizontal Pumps.

5.4 MATERIAL AND CONSTRUCTION

- (i) The centrifugal pumps shall conform to IS 1520.
- (ii) The pump casing shall be of heavy section close grained cast iron and designed to withstand 1.5 times the working pressure. The casing shall be provided with shaft seal arrangement as well as flanges for suction and delivery pipe connections as required.
- (iii) The impeller shall be of bronze, brass or stainless steel. This shall be shrouded type with machined collars. Wear rings, where fitted to the impeller, shall be of the same material as the impeller. The impeller surface shall be smooth finished for minimum frictional loss. The impeller shall be

secured to the shaft by a key.

- (iv) The shaft shall be of stainless steel and shall be accurately machined. The shaft shall be balanced to avoid vibrations at any speed within the operating range of the pump.
- (v) The shaft sleeve and wearing ring etc. shall be of bronze, brass or stainless steel.
- (vi) The bearings shall be ball or roller type suitable for the duty involved. These shall be grease lubricated and shall be provided with grease nipples/cups. The bearings shall be effectively sealed against leakage of lubricant or entry of dust or water.
- (vii) The shaft seal shall be mechanical type, so as to allow minimum leakage. A drip well shall be provided beneath the seal.
- (viii) The pumps shall be directly coupled to the motor/diesel engine shaft through a flexible coupling protected by a coupling guard.
- (ix) The pump and motor/diesel engine shall be mounted on a common robust bed plate fabricated from mild steel section. The bed plate shall have rigid, flat and true surfaces to receive the pump and motor/diesel engine mounting feet. The pump will be perfectly aligned with the motor/engine so as to avoid any vibration during operation at all variations of load.

5.5 ACCESSORIES

Each pump shall be provided with the following accessories: -

- (a) Sluice valves on suction and delivery.
- (b) Reducers, as may be required to match the sizes of the connected pipe work.
- (c) Non-return valve at the delivery.
- (d) Pressure gauge at delivery side between pump and the non-return valve.
- (e) Flexible coupling/connections shall be provided between Pump sets and Valves on suction and delivery sides of all the pump sets.

Note:

- 1) No butterfly valves shall be installed inside the pump room.
- 2) The size of the non-return valve and cut off (Sluice valve) shall not be less than the size of the initial delivery pipe.

5.6 INSTALLATION

- (i) The pump and motor/engine assembly shall be mounted and arranged for ease of maintenance and to prevent transmission of vibration and noise to the building structure or to the pipe work.
- (ii) The pump and motor/engine assembly shall be installed on suitable RCC foundation. The length and width of the foundation shall be such that 100 mm space is left all around the base frame. The height of foundation shall be so decided that the total weight of foundation block is 1.5 times the

operating weight of the pump assembly. The foundation shall be isolated from the floor by vibration isolating pads. Angle iron frame of size 35 mm x 35 mm x 3 mm shall be provided on the top edges of the foundation.

- (iii) More than one pump and motor assembly shall not be installed on a single base or cement concrete block.
- (iv) The suction/discharge pipe shall be independently supported and their weight shall not be transferred to the pump. It should be possible to disconnect any pump for repairs without disturbing the connecting pipe line.
- (v) A minimum clearance of 1 m around the main pumps shall be provided. For jockey pump-clearance of 75 cm shall be adequate.
- (vi) Sufficient space is to be left in front for the radiator of diesel engine for free discharge of hot air. Arrangement for discharging hot air to outside the pump house shall be provided so that hot air does not stagnate in the pump house.

CHAPTER-6

DIESEL ENGINE FOR FIRE PUMP

6.1 SCOPE

This chapter covers the details of requirements of a diesel engine for main fire pump to act as standby.

6.2 GENERAL

The diesel engine shall be suitable for automatic operation complete with necessary automatic starting gear, battery system and shall be complete with all accessories. Both engine and pump shall be assembled on a common bed plate, fabricated from mild steel channel.

6.3 DRIVE

The pump shall be only direct driven by means of a flexible coupling. The coupling between the engine and the pump shall allow each unit to be removed without disturbing the other. Coupling guard shall be provided. The speed shall be 1500 RPM.

6.4 DIESEL ENGINE

6.4.1 *Environment conditions*- The engine shall be suitable to operate under the conditions of environment at site.

6.4.2 *Engine Rating*- The engine shall be multi cylinder/vertical 4 stroke cycle, water cooled, developing suitable HP at the operating speed specified to drive the fire pump. Continuous capacity available for the load shall be exclusive of the power requirement of auxiliaries of the diesel engine, and after correction for altitude, ambient temperature and humidity for specified environment conditions. The engine rating shall be suitable to drive the pump at 150 percent of its rated discharge with at least 65 percent of rated head or 20% in excess of the maximum brake horsepower required to drive the pump at its duty point, whichever is higher. The engine shall have 10% overload capacity for one hour in any period of 12 hours continuous run.

The engine shall be:

- a) naturally aspirated, supercharged or turbo-charged and rather air or water-cooled.
- b) provided with an in-built tachometer to indicate rpm of the engine.

- c) suitable for cold starting for which suitable heaters shall be provided in lubricating oil.
- d) able to develop full load within 15 seconds from the receipt of the signal to start.
- e) The diesel engine shall conform to BS 649/ IS 1601/ IS 10002, amended up to date.

6.4.3 Engine Accessories- The engine shall be complete with following accessories:

- (i) Fly wheel dynamically balanced
- (ii) Direct coupling for pump and coupling guard
- (iii) Radiator with hoses, fan, water pump, drive arrangement and guard
- (iv) Air cleaner dry type
- (v) Fuel service tank with necessary pipe work
- (vi) Fuel filter
- (vii) Pump for lubricating oil and lub. oil filter
- (viii) Electric starting battery 12 V/24 V with 2 Nos. batteries
- (ix) Exhaust silencer with necessary pipe work
- (ix) Governor
- (x) Instrument panel housing all the gauges, including Tachometer, hour meter and starting switch with key (for manual starting)
- (xi) Necessary safety controls
- (xii) Winterisation arrangement
- (xiii) Hand operated semi rotary pump for filling the service tank
- (xiv) A standard kit of tools (this shall be kept on hand at all times)

6.4.4 Cooling System- The engine shall be radiator water cooled. The radiator assembly shall be mounted on the engine. The radiator fan shall be driven by the engine as its auxiliary with multiple fan belts. When half the belts are broken, the remaining belts shall be capable of driving the fan. Cooling water shall be circulated by means of an auxiliary pump of suitable capacity driven by the engine in a closed circuit.

6.4.5 Fuel System- The fuel system shall be gravity fed from the fuel tank to the engine driven fuel pump. The engine fuel tank shall be mounted either adjacent to the engine or suitably wall mounted on brackets. The fuel filter shall be suitably located to permit easy servicing.

The fuel tank shall be of welded steel construction (3mm thick) and of capacity sufficient to allow the engine to run on full load for at least 8 hours. The tank shall be complete with necessary floor mounted supports, level indicator (protected against mechanical injury) inlet, outlet, overflow connections and drain plug and piping to the engine fuel tank. The outlet should be so located as to avoid entry of any sediments into the fuel line to

the engine.

Any valve in the fuel feed pipe between the fuel tank and the engine shall be placed adjacent to the tank and it shall be locked in the open position.

All fuel tubing to the engine shall be with M.S.'C' class pipe with flexible hose connections where required. Pipe joints shall not be soldered and plastic tubing shall not be used.

The following shall be provided:

- i) A sludge and sediment trap shall be provided.
- ii) An inspection and cleaning hole
- iii) Means to enable the entire fuel system to be bled of air (Air relief cocks are not allowed; screwed plugs are permitted)

6.4.6 Lubricating Oil System- Forced feed lubricating Oil system shall be employed for positive lubrication. Necessary lubricating oil filters shall be provided, located suitably for convenient servicing.

6.4.7 Starting System- The starting system shall comprise of necessary batteries 12 Volts/ 24 Volts, starter motor of adequate capacity and axle type gear to match with the toothed ring on the fly wheel. Suitable protection to protect starting motor from excessively long cranking runs shall be suitably integrated with engine protection system.

The capacity of the battery shall be suitable for meeting the needs of the starting system.

The battery capacity shall be adequate for 10 consecutive starts without recharging with cold engine under full compression.

Three attempt starting facility shall be provided. If the engine fails to start after third attempt, the engine shall be locked out and suitable audio-visual alarm shall be given to indicate engine failure. The starter motor used for automatic starting may also be used for manual starting provided there are separate batteries for manual starting.

The scope shall cover all cabling, terminals, initial charging etc.

6.4.8 Exhaust System- The exhaust system shall be complete with residential grade silencer suitable for outdoor installation and silencer piping shall be extended up to 1 m, outside pump house duly insulated with 50 mm thick glass wool and 1.0 mm thick aluminum sheet cladding.

Retrofitted emission-control equipment shall be used having a minimum specified PM-capturing efficiency of at least 70%, type approved by one of the five CPCB recognized labs. (Recommendations of National Clean Air Program 2019 launched by Ministry of Environment, Forest and Climate

Change)

6.4.9 Engine shut down mechanism- This shall be manually operated and shall return automatically to the starting position after use.

6.4.10 Governing System- The engine shall be provided with an adjustable governor to control the engine speed within 5% of its rated speed under all conditions of load up to full load. The governor shall be set to maintain rated pump speed at maximum pump load.

6.4.11 Engine Instrumentation - Engine instrumentation shall include the following:-

- (i) Lub.oil pressure gauge
- (ii) Lub.oil temperature gauge
- (iii) Water temperature gauge
- (iv) Tachometer
- (v) Hour meter

The instrumentation panel shall be suitably mounted on the engine.

6.4.12 Engine protection devices - Following engine protection and automatic shut down facilities shall be provided:-

- (i) Low lub. oil pressure.
- (ii) High cooling water temperature.
- (iii) High lub. oil temperature.
- (iv) Over speed shut down

6.4.13 Pipe work- All pipe lines with fittings and accessories required shall be provided for fuel oil, lub.oil and exhaust systems.

6.4.14 Anti vibration mounting- Suitable vibration mounting duly approved by engineer-in-charge shall be employed for mounting the unit so as to minimize transmission of vibration to the structure.

6.4.15 Battery Charger-

Battery of diesel engine operated fire pump shall have separate charger from emergency power supply circuit. Necessary float and boost charger shall be incorporated in the control section of power and control panel with manual selection of boost charge, to keep the battery under trim condition. Voltmeter to indicate the state of charge of the batteries shall be provided. Where separate batteries are provided for automatic and manual starting, the charging equipment shall be capable of trickle charging both the batteries simultaneously. Equipment shall be provided to enable the state of charge of the batteries to be determined.

6.4.16 The engine installation shall be approved by the representative of engine

manufacturer (who shall carry out after sales service under AMC).

6.4.17 The following spare parts shall be supplied with the engine and kept on hand:

- a) Two sets of fuel filters, elements and seals;
- b) Two sets of lubricating oil filters, elements and seals;
- c) Two sets of belts(where used);
- d) One complete set of engine-joints, gaskets and hoses;
- e) Two injector nozzles;
- f) One complete set of piston rings for each cylinder; and
- g) One inlet valve and one exhaust valve).

CHAPTER-7

PIPE WORK

7.1 SCOPE

This chapter covers the requirements of pipe work in firefighting installations.

7.2 PLUMBING DESIGN

Pipe sizes shown in tender documents are purely for contractor's guidance. The contractor shall be responsible for selection of sizes as per detailed engineering to be done by him. Plumbing design to be done by the contractor shall incorporate the following: -

- (i)
 - (a) Sluice valves shall be provided at suction and delivery sides of pumps.
 - (b) External hydrant
 - (c) Fire service connection/inlet.
 - (d) Test valve.
 - (e) Drain connections.
- (ii) For testing the system healthiness and automatic operation on daily basis, one test pipe with sluice valve shall be provided in common discharge header. For avoiding wastage of water, this pipe shall discharge water in the tank.
- (iii) Non-return valve shall be provided at the delivery of each pump and fire service inlet. This shall be of swing type.
- (iv) Air release valves with ball valve shall be provided in the piping system for venting trapped air with a size of 25 mm for pipes up to 100 mm and 40 mm for larger pipes.
- (v) Plumbing drawings showing the sizes of pipe, valves, layout and other details shall be prepared and shall be got approved from the Engineer-in-Charge before the execution of the plumbing work.

7.3 PIPE MATERIALS

Pipes shall be of the following materials:

- (a) Mild steel heavy class (C-class) conforming to IS:1239 for sizes up to 150 mm.
- (b) Welded black steel pipe, Class 2, conforming to IS: 3589, for sizes greater than 150 mm. These pipes shall be factory rolled and fabricated from minimum 6mm thick M.S. Sheet for pipes upto 350 mm diameter and from minimum 7 mm thick M.S. sheet for pipes of 400 mm diameter and above.

MS pipes may be allowed for extension of existing systems which are laid with CI pipes.

- (c) Cast iron double flanged pipe, Class-A conforming to IS 1536 or IS: 1537 (to be provided only in underground application).

Note: For pipe work of Automatic Sprinkler System inside the building, Stainless Steel Pipes and fittings of grade AISI 304 as per JIS standard 3448 are also permitted particularly where replacement of pipes is not easy like areas above false ceiling etc., subject to the condition that these pipes with associated fittings are suitable to safely withstand the system test pressures.

- (d) (i) GI Pipe medium Class (B-class) conforming to IS:1239 (For Drain)
- (ii) Cadmium plated steel nuts/bolts/washers shall be used.
- (iii) Flex drop of stainless steel metallic pipe with mounting accessories, frame for installation on false ceiling.

7.4 PIPE JOINTS

- i) Electric welding joints shall be provided in the MS pipe work. Flanged joints shall be provided for connections to valves, pumps, air vessels etc. and also on straight lengths at suitable points to facilitate erection and subsequent maintenance.
- ii) For connection of C.I.Pipe, fittings shall also be of C. I. heavy grade conforming to IS:1538. The flanges shall be smooth faced and neoprene gasket shall be provided between joints. All bolt holes in flanges shall be drilled. The drilling of each flange shall be in accordance with the relevant Indian Standards. Where un-avoidable and to connect underground pipe with risers, MS pipe may be used in the form of distant pieces. The joint between C.I. and MS pipe shall be flanged type. MS pipe laid at such locations shall be provided anti-corrosive treatment as per Para 7.5.
- iii) Mild steel flanges shall be in accordance with Table - 17 of IS : 6392 i.e. "Plate Flanges for Welding" and flange thickness shall be as under. Gasket thickness shall not be less than 3 mm.

Pipe diameter	Flange Thickness
200 mm	24 mm
150 mm and 125 mm	22 mm
100 mm and 80 mm	20 mm
65 mm	18 mm
40 mm and below	16 mm

- iv) Fittings installed underground shall be of cast iron 'heavy' grade conforming to IS 1538 whereas those installed above ground shall normally be of medium grade wrought steel or mild steel conforming to IS 1239 (Part 2) or malleable iron fittings conforming to IS 1879.
- v) All hardware items such as Nuts, Bolts, Washers shall be of appropriate size. Washers shall be used on both sides of the bolt.

7.5 ANTI-CORROSIVE PROTECTION ON UNDER GROUND MS PIPE

Corrosion protection tape shall be wrapped on MS pipes to be buried in

ground. This corrosion protection tape shall comprise of coal tar/asphalt component supported on fabric of organic or inorganic fibre and minimum 4 mm thick and conform to requirement of IS : 10221-Code of practice for coating and wrapping of underground mild steel pipe line. Before application of corrosion protection tape all foreign matter on pipe shall be removed with the help of wire brush and suitable primer shall be applied over the pipe thereafter. The primer shall be allowed to dry until the solvent evaporates and the surface becomes tacky. Both primer and tape shall be furnished by the same manufacturer. Corrosion protection tape shall then be wound around the pipe in spiral fashion and bounded completely to the pipe. There shall be no air pocket or bubble beneath the tape. The overlaps shall be 15 mm and 250 mm shall be left uncoated on either end of pipe to permit installation and welding. This area shall be coated insitu after the pipe line is installed. The tapes shall be wrapped in accordance with the manufacturer's recommendations. If application is done in cold weather, the surface of the pipe shall be pre- heated until it is warm to touch and traces of moisture are removed and then primer shall be applied and allowed to dry.

Holiday Testing for wrapping and coating is essential. Holiday testing may preferably be carried by flexible and detachable ring probe, which will enable the entire 360° of the surface of the pipe to be scanned.

At least 10 percent of all the welded joints shall be radio graphically tested and half of the joints radio graphed shall be the 'field joints'.

7.6 VALVES

Each pump shall be provided with a non-return valve and a sluice valve on the delivery side, the sluice valve being installed on the upstream side of the non-return valve. A pressure gauge shall also be provided between the pump and the non-return valve. The size of the non-return valve and cut off (sluice) valve shall not be less than the size of the initial delivery pipe and, in no case, less than the delivery outlet of the pump. No butterfly valves shall be installed inside the pump room.

Sluice valve shall conform to IS: 780.

Butterfly valve, wherever used, shall conform to IS:13095.

All valves shall be suitable to with-stand the pressure in the system and rating shall be PN 1.6. All valves shall be right handed (i.e. handle or key shall be rotated clock wise to close the valve), the direction of opening and closing shall be marked and an open/shunt indicator fitted.

(i) The material of valves shall be as under:

- Body - Cast iron
- Disc - Cast Bronze or Stainless Steel
- Seat - Either integral or Nitrile rubber
- O-ring - Nitrite/ Silicon

(ii) Non return valves shall be swing check type in horizontal run and lift check type in vertical run of pipes.

- (iii) Air release valves shall be of gunmetal body.

7.7 ISOLATION VALVES :

- (i) Isolation valves shall be provided in the network to enable isolation of any section of the network without affecting the flow in the rest. These valves are distributed according to the general layout of the installation. The isolation valves shall be normally located near the loop junctions. Additional valves shall be provided in the segments where the length of the segment exceeds 300 m.
- (ii) Cut-off valves shall conform to IS 780 (PN 1.6 rating)/IS 14846, Class 3.
- (iii) Butterfly valves can be accepted subject to the condition that the valves of diameter exceeding 150 mm shall necessary be of gear operated.
- (iv) All Cut-off valves shall be of the right-hand type and enclosed in properly constructed surface boxes, at least 1 m² in area so as to allow for broken joints being easily remade. The top of the surface box shall be 80 mm above ground level, except where it is located on a road. Valve wheels shall have an arrowhead engraved or cast thereon showing direction for turning open and close.

It is recommended that the position of the surface box be indicated by an iron plate painted fire red with distinct lettering. Such plates shall also show the open and close direction as cast or indicated on the valves and the serial number of the sluice valve.

- (v) Locations where vehicles can pass shall be avoided for provision of valve below ground. (CPWD Specs Para 7.10 (xii))
- (vi) In case of installations in earthquake prone zones, flexible couplings shall be used for jointing purposes at required locations.

- 7.8** Valves in fixed firefighting installations shall have supervisory switch with its signalling to fire alarm panel or to have chain(s), pad lock(s), label and temper-proof security tag(s) with serial number to prevent tempering/unauthorized operation. These valves shall be kept in their intended 'open' position.

7.9 STRAINERS

Stainless steel strainers shall have minimum 1 mm thick screen with 3 mm perforations. Strainers shall be provided with flanges.

7.10 ORIFICE PLATE

Orifice plate shall be made of 6 mm thick stainless steel and shall have an identification tag projecting beyond any flange between which it is clamped. The orifice shall be plain central hole without burs and diameter

not less than one-half of the internal diameter of the pipe to which it is fitted.

7.11 INSTRUMENTS

- (i) Pressure gauge of appropriate range and 150 mm diameter size shall be provided.
- (ii) The pressure gauge shall be duly calibrated before installation and shall be complete with shut off valve.

7.12 AIR VESSEL

Air vessel shall be provided on top of each riser and shall be fabricated out of 8 mm thick M.S. Sheet. The ends shall be dished. This shall be of 250 mm diameter, 1.2 m high and installed vertically on suitable legs. The legs shall be provided with M.S. Plate of size 75 mm x 75 mm x 5 mm at the bottom so that the legs do not puncture the roof. The legs shall be grouted in CC foundation. Flange connection shall be provided for connection with wet riser pipe. Air release valve and pressure gauge with shut off valve shall be provided. The air vessel shall be tested at 25 kgf/cm² pressure before installation.

7.13 INSTALLATION

- (i) The installation work shall be carried out in accordance with the detailed drawings prepared by the contractor and approved by the Engineer-in-charge.
- (ii) In pipe above ground level, expansion loops or joints shall be provided to take care of expansion or contraction of pipes due to temperature changes.
- (iii) Tee-off connections shall be through equal or reducing tees, otherwise ferrules welded to the main pipe shall be used. Drilling and tapping of the walls of the main pipe shall not be resorted to.
- (iv) Open ends of piping shall be blocked as soon as the pipe is installed to avoid entrance of foreign matter.
- (v) Piping installation shall be supported on or suspended from structure adequately. The contractor shall provide, clamps, hangers etc. in accordance with Para 7.16.

Proper lines and levels shall be maintained while installing exposed pipes.

- (vi) Pipe supports in pump house shall be floor mounted and of mild steel/ G. I. Spacing of pipe supports shall not be more than that specified below:

Nominal Pipe Size (mm)

Spacing (m)

20 and 25	2.00
32 to 125	2.50
150 and above	3.00

Extra supports shall be provided at the bends and at heavy fittings like valves to avoid undue stress on the pipes.

- (vii) Anti-vibration pads, springs or liners of resilient and non-deteriorating material shall be provided at each support, so as to prevent transmission of vibration through the supports.
- (viii) Pipe sleeves of diameter larger than the pipe by least 50 mm shall be provided wherever pipes pass through walls and the annular spaces shall be filled with felt and finished with retaining rings.
- (ix) (a) Vertical risers shall be parallel to walls and column lines and shall be straight and in plumb. Risers passing from floor to floor shall be supported at each floor by clamps as per Para 7.16.
 (b) The space in the floor cut outs around the pipe work shall be closed using cement concrete (1:2:4 mix) or steel sheet, from the fire safety considerations, taking care to see that a small annular space is left around the pipes to prevent transmission of vibration to the structure.
 (c) Riser shall have suitable supports at the lowest point.
- (x) Where mild steel pipes shall be buried under ground the same shall be treated in accordance with Para 7.5 before laying. The top of the pipes shall be not less than 1m below the ground level. Where this is not practicable, permission of the Engineer-in-charge shall be obtained for burying the pipes at lesser depth. Masonry or C.C.blocks shall be provided for supporting the pipes at interval in accordance with Para 7.11(vi). After the pipes have been laid, the trench shall be refilled with the excavated soil in layers of 20 cm and rammed and any extra soil shall be removed from the site of work by the contractor.
- (xi) Underground pipe shall be laid at least 2m away from the face of the building preferably along the roads and foot paths. As far as possible laying of pipes under road, pavement and large open spaces shall be avoided. Pipes shall not be laid under buildings and where unavoidable, these shall be laid in masonry trenches with removable covers and cut-off valves shall be provided at points of entry and exit.
- (xii) Pipe over ground shall be painted in red color as per Para 1.13. Suitable identification shall be provided to indicate the run of underground pipe wherever the route of underground pipe cannot be ascertained from the location of yard hydrant/isolating valves.
- (xiii) It shall be made sure that proper noiseless circulation is achieved in the system. If proper circulation is not achieved due to air-bound connections, the contractor shall rectify the defective connections. He shall bear all the expenses for carrying out the above rectification, including the tearing up and refinishing of floors, walls, etc. as required.

7.14 FLUSHING ARRANGEMENT

Flushing connections with isolation valves should be provided at suitable locations in the firewater ring main.

7.15 PRESSURE TESTING

- (a) All piping shall be tested to hydrostatic test pressure of at least one and a half times the maximum operating pressure, but not less than 10 kgf/sq.cm for a period not less than 24 hours. While Hydro Testing, inclusion of cut-off valves in the mains to be tested can be avoided. All leaks and defects in joints revealed during the testing shall be rectified to the satisfaction of the Engineer-in-Charge.
- (b) Piping repaired subsequent to the above pressure test shall be re-tested in the same manner.
- (c) System may be tested in sections and such sections shall be securely capped.
- (d) Pressure gauges may be capped off during pressure testing of the installation.

7.16 PIPE SUPPORTS

For installing pipes vertically or horizontally inside the building standard pipe supports of reputed make shall be used. Following supports shall be used.

- (i) Split pipe support clamps with rubber lining for vertical, horizontal and roof hanging.
- (ii) Clevis Hangers for horizontal supports to adjust varying heights.
- (iii) Sprinkler Hangers for horizontal supports for pipes from 15 mm dia to 150 mm dia.

Fasteners and fully threaded rods shall be used for installing the pipe supports. The sizes of pipe supports and installation shall be in accordance with manufacturer's recommendations. Some of the typical supports are shown in the Figure-9.

For pipes of size 100 mm and above, with the prior approval of Engineer-in-Charge, 'U' clamp with dash fastener may be used for supporting horizontal pipe from ceiling.

7.17 MEASUREMENT

Measurements of plumbing work shall be on following basis:-

- (a) Piping shall be measured along the centre line of installed pipes including all pipe fittings and accessories but excluding valves and other terms for which quantities are specifically indicated in the schedule of work. No separate payment shall be made for fittings and accessories.

- (b) The rates for piping work shall include all wastage allowances, flanges pipe supports, hangers, excavation, refilling, testing, nuts and check nuts, vibration isolators, suspension where specified or required, and any other item required to complete the piping installation. None of these items will be separately measured and paid.

CHAPTER-8

FIREFIGHTING ACCESSORIES

8.1 SCOPE

This chapter covers landing valves, first aid hose reels, hose pipes, branch pipes etc., which are vital tools for firefighting.

8.2 LANDING VALVE

Landing valves are provided in the system for connection of hose pipes for discharging water for fighting fire by fire brigade or trained personnel.

8.2.1 The landing valves shall be as per IS: 5290

8.2.2 Material of construction

- (i) Body, outlet and cap etc. : Bronze or Aluminum alloy or stainless steel
- (ii) Spindle : Brass for Bronze body, stainless steel for Aluminum alloy and stainless steel body.
- (iii) Hand wheel : Mild steel or cast iron.

8.2.3 The water discharge shall be not less than 900 lpm for single head valves at 7 kgf/cm² pressure.

8.2.4 Installation

8.2.4.1 The landing valve shall be fitted to a T-connection of the riser at the landing in such a way that the valve is in the center of the internal hydrant opening and at a height of 900 mm from floor level.

8.2.4.2 The valve base shall be vertical and the valve facing outside. There should be no hindrance in operation of the handle.

8.3 FIRST AID HOSE REEL

First Aid Hose Reel is meant for delivering small quantity of water in early stage of fire and can be operated even by untrained personnel, and thus provides a most effective firefighting facility. It shall consist of 20 mm (nominal internal) diameter hose tubing length wrapped around a reel with water inlet pipe, stop valve and shut-off nozzle. The entire assembly is mounted on a wall bracket and can swing 180 degrees. The water inlet shall be connected directly to the riser/down-comer mains by means of 37 mm socket and valve. The hose tube can be pulled out easily for the purpose of discharge of water on fire.

8.3.1 First aid hose reel shall be as per IS-884. The coupling, branch pipe and nozzle shall be as per IS:8090.

8.3.2 Material of Construction -

- (i) Hub and sides : Aluminum Alloy / Mild steel / Aluminum sheets.
- (ii) Wall Bracket : Cast iron / Mild steel.
- (iii) Hose tube (20 mm) :Thermoplastic (Textile Reinforced)
(nominal internal dia) Type-2 as per IS-12585
- (iv) Nozzle with branch Pipe : Brass
- (v) Stop Valve(Ball Valve) : Gun metal

Normally M S construction is used. Other material may be used in areas having corrosive atmosphere.

8.3.3 The water flow rate shall be not less than 24 lpm and the range of jet shall be not less than 6 m.

8.3.4 Installation

8.3.4.1 First aid hose reels are installed with internal hydrant (Para 2.4.1.7.) space for which is provided as per Para 3.2.4. Where space is not provided, first aid hose reel shall be installed in suitable size MS cabinet made from 2 mm thick sheet with glass door. The cabinet shall be painted red as per Para 1.13. The size of the cabinet shall be such that there is no obstruction in swinging the hose reel. The location of cabinet shall be such that it does not form an obstruction in passage/escape route.

8.3.4.2 The length of hose tube shall be such that the nozzle of the hose can be taken into every room and within a range of 6 m from any part of the room.

8.3.4.3 There shall be no obstruction in swinging the hose reel and should be installed above landing valve where provided.

8.3.4.4 The inlet valve shall be at 900 mm above floor level.

8.3.4.5 Hose reel bracket should be firmly grouted on the wall with the help of rawl bolts.

8.4 FIRE HOSE DELIVERY COUPLING, BRANCH PIPE AND NOZZLES:-

8.4.1 These are important accessories used for firefighting operations.

8.4.2 Material of Construction

8.4.2.1 Copper Alloy

8.4.2.2 Aluminum alloy

8.4.2.3 Stainless Steel

8.4.3 Delivery Hose Couplings

8.4.3.1 The delivery hose couplings consist of male half coupling and female half coupling. Grooves are provided on outer side on both coupling for binding hose pipes with wires. In female coupling spring loaded cam tooth is provided for holding male half coupling in position. Male half coupling and female half coupling are provided on both sides (i.e. on one side male and on other side female) of hose pipes. Two or more pipes can be joined together with the help of these couplings instantaneously.

8.4.3.2 **Sizes:-** These are available in two sizes i.e. 63 mm and 70 mm. Normally size 63 mm is used.

8.4.4 **Branch Pipe and Nozzle :-** Branch Pipes with nozzle are mounted at the end of hose pipe. Branch pipe is properly finished and free from sharp edges. During operation, a fireman has to hold the branch pipe. One end of branch pipe is fixed with hose coupling and the other end is threaded to fit the nozzle. Nozzle is tapered pipe with one end threaded internally which is fixed on branch pipe. The size of other end i.e. nozzle shall be 20 mm (nominal internal diameter). Spare Branch pipes and nozzles to the extent of 10 percent of the above requirements, with a minimum of two sets, shall always be kept readily available in fire control room/pump room.

8.5 FIRE SERVICE INLET AND FIRE SERVICE CONNECTION

8.5.1 These are provided for connection of fire service hose pipes for either directly pressurizing the system with their pumps or filling water in the tank from a distance. In the first case non-return valve with butterfly valve shall be provided for holding water pressure. Fire service inlet shall be provided with each wet riser/down comer and the ring main. The arrangement has been shown in Fig.5. These are fixed to 150 mm diameter pipe and located in MS Box made of 2 mm thick mild steel sheet with openable glass cover.

8.5.2 These shall be as per IS: 904.

8.5.3 Material of Construction

8.5.3.1 Copper Alloy

8.5.3.2 Aluminum Alloy

8.6 HOSE PIPES

8.6.1 Hose pipes shall be rubber lined woven jacketed and 63 mm in diameter. They shall conform to Type A (Re-inforced rubber lined) of IS: 636. They shall be flexible and capable of being rolled. Length of hose pipe will be 15 m.

8.6.2 The hose pipe shall be complete with male and female coupling at the ends as per Para 8.4.3.

Besides keeping hose pipe with internal hydrant and yard hydrant, spare hose pipes to the extent of 10 percent of the above requirements, with a minimum quantity of 30 m shall always be kept readily available in fire control room/pump room. Such spare hose shall be in 15 m lengths, readily attached to couplings.

CHAPTER-9

AUTOMATIC SPRINKLER SYSTEM

9.1 SCOPE

This chapter covers the general requirement of selection, design, installation, testing, commissioning and maintenance of automatic sprinkler system for firefighting in buildings used for other than industrial, storage purpose, hotels and mercantile buildings.

9.1.1 References: For additional information regarding definitions, planning, design, hydraulic calculations, tables etc. following documents are to be referred to:

- (i) IS: 15105: - Design and Installation and Maintenance of Fixed Automatic Sprinkler Fire Extinguishing Systems- Code of Practice (First Revision).
- (ii) IS: 9972: - Specification for Automatic Sprinkler Heads for Fire Protection Service (First Revision).

9.2 INTRODUCTION

Firefighting installations described in Para 2.2.1 (i) to (iii) are to be operated manually. Delay in undertaking manual operation due to late detection and or response, may result in spread of fire. In automatic sprinkler system, sprinkler heads are provided throughout the areas to be protected at specified locations such as roof or ceiling, walls, between racks, below obstructions and fitted with water supply lines permanently charged with water under specified pressure. The sprinklers operate at pre-determined temperature to discharge water over the affected area below and provide an adequate distribution of water to control or extinguish fire. Only those sprinklers which are in the vicinity of fire that is those become sufficiently heated operate. Operation of sprinkler results in flow of water which initiates fire alarm. Thus sprinklers perform two functions i.e. first to detect fire and then to provide an adequate distribution of water to control or extinguish it. Water distribution from ceiling level, cools down the hot gas which forms beneath the ceiling of enclosure in which fire is developing. This will prevent spread of fire to adjoining areas and contain damage to limited area.

It should not be assumed that the provision of sprinkler system entirely obviates the need for other means of fighting fire and it is important to consider the fire precaution in the premises as a whole.

The system shall be installed only where there is no danger of freezing of water in the pipes at any time.

Typical layouts of sprinklers have been shown in Figure 11.

9.3 CLASSIFICATION OF OCCUPANCIES AND PROVISION OF AUTOMATIC SPRINKLER FIRE SYSTEM

Sprinklers are provided in industrial and non-industrial buildings. The design of sprinkler installation depends upon type of occupancy. For the purpose of designing and installation of automatic sprinkler system, buildings are categorized under the following classes in IS: 15105.

- (a) Light hazard class
- (b) Moderate/Ordinary hazard class
- (c) High hazard class
- (d) Storage hazards

For details of classifications, IS: 15105 is to be referred. Light Hazard Occupancies shall be understood as those with low fire loads and with materials within having low rates of heat release. Light Hazard Occupancies are of non-industrial type subject to the condition that “No single compartment greater than 210 m² are allowable within light hazard occupancies and such compartments shall be fire separated by walls having 30 min rating and doors. Otherwise the sprinkler system shall be designed as per Ordinary Hazard Occupancy.”

Office buildings (excluding store rooms), education institutions, hospitals (excluding kitchens, stores, utilities), libraries, museums, nursing homes, prisons and residential apartments are classified under light hazard occupancies.

Airport terminal buildings, car parking areas within building or basement, departmental stores/retail shops are classified under ordinary hazard class.

In order to satisfy above conditions, all buildings classified under Light Hazard shall be designed under Ordinary Hazard class. Accordingly these specifications cover Ordinary Hazard class only.

9.4 PLANNING

9.4.1 Automatic sprinklers shall be installed wherever required in terms of Table 7 of Part-4, Vol-1 of NBC 2016 (amended up to date). These requirements for installation of automatic sprinkler system have been reproduced in Appendix-A.

Automatic Sprinklers shall also be installed in false ceiling voids exceeding 800 mm in height.

Ramps at all levels shall also be protected with sprinklers

Pressure in the sprinkler installation piping shall not exceed 7 bar and pressure at the most remote sprinkler at any level shall not be less than 0.5 bar and also not more than 5 bar.

9.4.2 Extent of Sprinkler Protection: -

Sprinklers shall be provided, but for following exceptions:

- (a) Areas, rooms or places where the water discharged from a sprinkler may pose a fire or explosion or toxic hazard. In such areas alternative arrangement shall be made.
- (b) Stairs, spaces below stair headings (but not rooms above a stair) and lift wells. Any part of the building not provided with sprinkler protection shall be fire separated by walls. Fire doors not less than 1 hour in fire resistance shall be provided in the opening of such walls.
- (c) Wash rooms, toilets and WCs (but not cloak rooms) of area less than 5m². If area of these rooms exceed 5m², these shall be provided with sprinkler protection unless fire separated by walls and all openings in the walls are protected.
- (d) Sprinklers shall not be required in electrical equipment rooms where all of the following conditions are met:
 - i) The room is dedicated to electrical equipment only.
 - ii) Only dry-type electrical equipment is used.
 - iii) Equipment is installed in a 120 minutes fire-rated enclosure including protection for penetration in walls.
 - iv) Cable coating is done in trays or trenches to prevent flame spread.
 - v) Storage is not permitted in the room.In addition, for firefighting provisions to be provided for Substation/Transformers, Electrical MV main distribution panel and lift panel *Clause 3.4.6.3 and 3.4.6.4, Page-22-23 of NBC 2016, Vol-1, Part-4 may be referred to. (see Appendix-G)*
- (e) Rooms like server room or electrical control room where alternate protection by other automatic extinguishing systems, (for example gas, powder and water spray).
- (f) In areas having height 17 m or above such as in atria, sprinkler installations may be rendered ineffective and hence may be avoided.

9.4.3 The area to be protected by sprinkler is divided in to various zones. For detecting operation of sprinkler in a zone, flow switches are provided which are wired to an annunciation panel installed in the Fire Control Room. In the event of operation of sprinkler(s) in an affected area. The annunciation panel will give audio-visual alarm and indicate the affected zone. This arrangement will be independent of fire alarm system.

9.4.4 Design, Density and Assumed Maximum Area of Operation (AMAO):- This is different for different hazards classified in Para 9.3. For moderate hazard, water discharge shall be at least 5 litre/min/m² over an assumed area of operation covering 360 m².

9.4.5 Sprinkler Spacing, Arrangement, Distribution and Locations:- Sprinkler heads may be installed on ceiling and or side walls. For selection of number of sprinkler and their location in a given area, following factors shall be considered:

- | | |
|--|--------------------|
| (i) Maximum Area Coverage per Sprinkler | |
| (a) Ceiling sprinkler | 12 m ² |
| (b) Side wall sprinkler : | |
| • Combustible ceiling | 7.5 m ² |
| • Non-Combustible ceiling | 9 m ² |
| (ii) Maximum Distance between Sprinklers | |
| (a) Ceiling sprinkler | 3.5 m |
| (b) Side wall sprinkler | |
| • Combustible ceiling | 2.7 m |
| • Non-combustible ceiling | 3 m |
| (iii) Minimum Distance between Sprinklers | 1.8 m |
| (for Ceiling as well as Sidewall sprinklers) | |

Note: In case of intermediate ceiling suspended sprinklers, protecting commodities in racks, distance lower than 1.8 m may be considered if necessary.

- | | |
|--|-----------------------------|
| (iv) Maximum distance of sprinklers from end walls : | it shall not exceed |
| (for ceiling & sidewall sprinklers) | half of the allowable |
| | distance between sprinklers |

Note: For ceiling sprinklers:

- a) where the external walls are combustible or built with metallic or otherwise or open sided; and in case of open joisted ceilings or where the roof has the rafters exposed, the distance between the boundary and the sprinklers shall not exceed 1.5 m.
 - b) Distance shall be measured perpendicular to the wall.
- (v) Sprinklers shall not be located at a distance less than 100 mm from the wall (for ceiling sprinklers).
Sprinklers shall not be located at a distance less than 100 mm from the end wall (for sidewall sprinklers)

While designing sprinklers installation, the recommendation of sprinkler manufacturer shall be considered. Typical layout of side wall sprinklers has been shown in Figure 14.

9.4.6 Spacing below Sprinkler Heads: - Clear minimum space of 0.5 m shall be maintained below the deflector of sprinkler head.

9.4.7 Ceiling Sprinkler deflector location and orientation in relation to building structure:

9.4.7.1 Roofs and ceilings:

For conventional and spray type of sprinklers, the sprinklers shall be installed in such a way that the deflectors are at distances below ceilings as shown in Table 9.1.

Table 9.1 Sprinkler Location Below Ceilings [Clause 9.4.7.1]				
S. No.	Type of ceiling	Distance below ceilings (in mm)		
		Minimum	Maximum	Preferred
(1)	(2)	(3)	(4)	(5)
i)	Combustible, asbestos cement sheets, wired glass and other types of frangible	75	300	150
ii)	Combustible with exposed rafters and/or open joists	75	150	-
iii)	Non combustible - either plane or arched or sloping	75	450	300

9.4.8 Sidewall Sprinkler Deflector Location and Orientation in relation to building structure:

- i) Distance between sprinklers and the ceiling shall not exceed 150 mm. If specifically approved for use and listed so, the distances between ceilings and the sprinklers can be increased up to 450 mm.
- ii) Vertical side wall sprinkler deflectors shall be located not more than 150 mm or less than 100 mm from the wall from which they are projecting.
- iii) Sprinklers shall be so located to minimize obstructions (to discharge) either on parallel or perpendicular sides thereof. If required, additional sprinklers shall be provided to obviate the obstructions.
- iv) **Sidewall Sprinkler Obstruction:** Sprinklers shall be located at least 1.2 m away from any lighting, fan and similar fixtures either in front of or on the same wall where the sprinklers are mounted. For any obstruction (to discharge) including lighting, fan and the like beyond 1.2 m, distances A and B (as indicated in Fig. 9.2 and 9.3) shall be maintained as per the Tables 9.2 and 9.3 given below. In case these distances can not be maintained, the sprinkler shall not be allowed at such location. (See Fig. 9.2 and 9.3).
- v) Clearance between the top of storage if any to the deflector shall not be less than 450 mm.
- vi) Side wall sprinklers in rooms shall neither be installed above the grills of air conditioner nor within 450 mm thereof on the same wall.

Table 9.2 Sidewall Sprinkler Location in Relation to Obstructions (lighting, fan and similar fixtures) -Facing across the wall (see Fig. 9.2)(Clause 9.4.8 iv)		
S. No.	Distance (A) between Sprinklers and the Obstruction on Side (mm)	Maximum allowable Distance (B) between Deflector above bottom of Obstruction when Sprinkler can be allowed

		(mm)
(1)	(2)	(3)
a)	Up to 1200	Not allowed
b)	More than 1200 but less than 1500	25
c)	More than 1500 but less than 1650	50
d)	More than 1650 but less than 1800	80
e)	More than 1800 but less than 1950	100
f)	More than 1950 but less than 2100	150
g)	More than 2100 but less than 2250	180
h)	More than 2250 but less than 2400	230
i)	More than 2400 but less than 2550	280
j)	More than 2550	350

Table 9.3 Sidewall Sprinkler Location in Relation to Obstructions (lighting, fan and similar fixtures)-**Along the same wall** (see Fig. 9.3) (Clause 9.4.8 iv)

S. No.	Distance (A) Between Sprinklers and the Obstruction on Side (mm)	Maximum allowable Distance (B) between Deflector above bottom of Obstruction when Sprinkler can be allowed (mm)
(1)	(2)	(3)
a)	100 to 150	25
b)	More than 150 but less than 300	50
c)	More than 300 but less than 450	80
d)	More than 450 but less than 600	115
e)	More than 600 but less than 750	150
f)	More than 750 but less than 900	180
g)	More than 900 but less than 1050	200
h)	More than 1050 but less than 1200	230
i)	More than 1200 but less than 1350	250
j)	More than 1350 but less than 1500	300
k)	More than 1500 but less than 1650	330
l)	More than 1650 but less than 1800	350
m)	More than 1800 but less than 1950	380
n)	More than 1950 but less than 2100	430
o)	More than 2100 but less than 2250	450

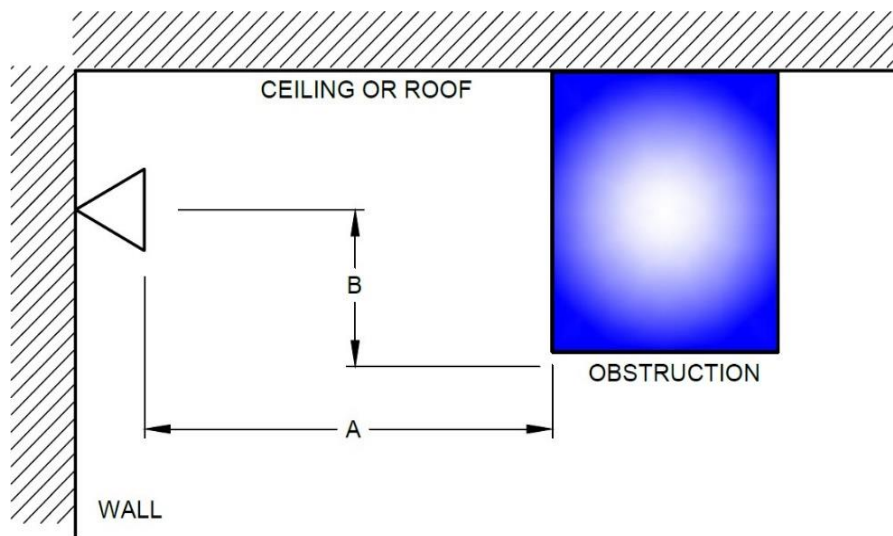

ELEVATION VIEW

Fig. 9.2 SIDEWALL SPRINKLER FACING OBSTRUCTION

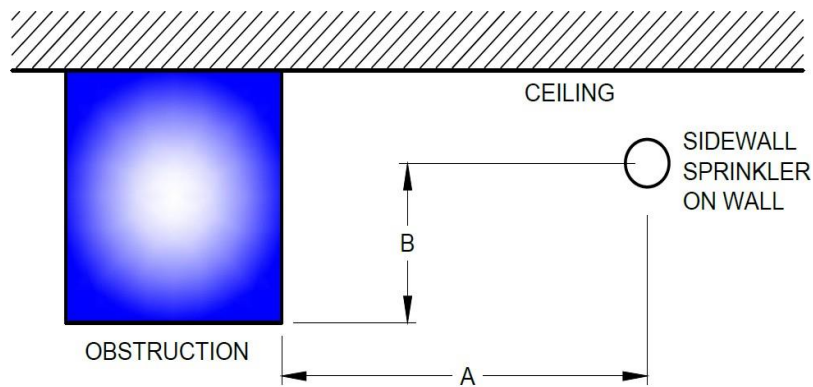

ELEVATION VIEW

Fig. 9.3 SIDEWALL SPRINKLER OBSTRUCTION ALONGSIDE

- vii) Horizontal sidewall sprinkler shall be located not more than 100 mm and are allowed to be located with their deflectors less than 100 mm from the wall on which they are mounted.
- viii) Deflectors of the sprinklers shall be aligned parallel to the ceilings or roofs.
- ix) When installed under a sloped ceiling (1 in 6), sidewall sprinklers shall be located at the high point of slope and positioned so as to discharge down the slope.
- x) Where vertical side of a beam/projection from a wall is used for installing a sidewall sprinkler, additional sprinklers shall be installed below the soffit if the width of beam or projection from the wall exceeds 200 mm.

- xi) When soffits used are within 200 mm in width or projection from the wall, additional sprinklers shall not be required subject to the deflector of the sprinklers falling within prescribed distance as contained in 9.4.8 (ii), (vi) & (vii) above.

9.4.9 Concealed Spaces:-

9.4.9.1 If the height of the concealed space at roof and floor is not greater than 0.8m, the spaces shall be sprinkler protected only if they contain combustible materials or are constructed with combustible materials. Electrical cables with voltage less than 250 V, single phase, with a maximum of 15 cables per tray, are allowed.

9.4.9.2 Spaces between roofs and ceiling more than 0.8 m deep shall be sprinkler protected as follows:-

- (i) Concealed spaces less than 5m² in area shall not require sprinkler protection.
- (ii) Sprinkler heads shall be provided considering the space as any other area in the building.
- (iii) Sprinkler heads may be connected individually with the range/distribution pipes below, which shall be sized by taking the room and concealed space sprinklers cumulatively.
- (iv) Sprinkler heads for concealed space and for the room may be connected with separate range/distribution pipes connected, with common feed pipe. The common feed pipes shall be not less than 65 mm diameter.

9.4.10 Obstruction below Sprinklers:- Sprinklers shall be fitted under the following types of obstruction which are either:

- (a) more than 0.8 m wide and less than 150 mm from the adjacent walls or partitions

OR

- (b) more than 1 m wide.

9.4.11 Pipe Sizing and Design: - Sprinkler heads located as per Para 9.4.5 to 9.4.10 shall be connected with pipe lines permanently charged with water. Depending upon location of sprinkler heads and site conditions, sprinkler heads may be connected with range and distribution pipes. A number of options have been indicated in Figure-12.

The pipes connecting the sprinkler heads are to be sized depending upon number of sprinkler heads and arrangement of their connection. Main elements of a sprinkler installation are shown in Figure-11. Various pipes connecting the sprinkler heads are termed as below:

- (a) Range Pipe
- (b) Distribution Pipe
- (c) Main Distribution Pipe
- (d) Riser

Sizes of pipes are to be calculated from various tables and hydraulic calculations given in IS: 15105.

Pipe sizes shall be determined using one of the following methods:

- a) **Pre-calculated system:** applicable only where light and ordinary occupancies where the aggregate floor plate area (in one or more floors combined) is 5000 m² or less (except where gridded or looped layouts are used).

Pre-calculated pipework is applicable only to the extensions of old pre-calculated systems.

- b) **Fully calculated system:** applicable for
 - i) Light and ordinary occupancies where the aggregate floor plate area (in one or more floors combined) exceeds 5000 m².
 - ii) High hazard occupancies,
 - iii) Storage occupancies, and
 - iv) All occupancies where conventional and special sprinklers are used like ESFR, LD, EC, intermediate, etc.

Some guidelines relating to pre-calculated system are given below:

- a) Pipe less than 25 mm diameter is not to be used.
- b) There shall not be more than 6(Six) sprinklers in any range.
- c) Range and distribution pipe nominal sizes shall be selected from Table 9.4 and Table 9.5 respectively.

TABLE 9.4
RANGE PIPE NOMINAL SIZES FOR VARIOUS PIPE LAYOUTS IN
MODERATE/ORDINARY HAZARD INSTALLATIONS

	Range Pipe Layout	Pipe Nominal Bore (mm)	Maximum Number of Sprinklers to be fed by Pipe of size listed
	(1)	(2)	(3)
(a)	(1) Range(s) at remote end of each distribution pipe spur in end feed layout:		
	(i) Last two ranges in two end-side layout	25	1
		32	2
	(ii) Last three ranges in three end-side layout	25	2
		32	3
(2) Last range in all other	25	2	

	layouts.	32	3
		40	4
(b)	All other ranges in case of 1(i), 1(ii) & (2) above	25	3
		32	4
		40	6

**TABLE 9.5
DISTRIBUTION PIPE NOMINAL SIZE IN MODERATE/ORDINARY HAZARD
INSTALLATIONS-AND MAXIMUM NUMBER OF SPRINKLERS**

Distribution Pipes	Type of Layout	Distribution Pipe Nominal (mm)	Maximum Number of Sprinklers to be fed by Pipe size listed
(1)	(2)	(3)	(4)
(a) At extremities of the installation	Two end side layouts	32	2
		40	4
		50	8
		65	16
(b) Last three ranges	All other layouts	32	3
		40	6
		50	9
		65	18
(c) Between design points and the Installation Control Valve	All	To be calculated as per 10.4.4 (b) of IS 15105	

Typical pipe sizes for sprinkler installation have been shown in Figure-13.

9.4.12 Components of sprinkler system:- Following types of valves are used in the installations:

- (a) Stop Valves
- (b) Test Valves
- (c) Drain Valves
- (d) Flushing Valves
- (e) Check Valves
- (f) Installation Control Valves
- (g) Pre action valves

(h) Subsidiary valves

The location of above valves shall be as under:

9.4.12.1 **Test Valve.** - For testing hydraulic alarm or electric alarm by drawing water from downstream side, test valve shall be connected with downstream of the water flow alarm.

9.4.12.2 **Drain Valve:** - For drainage of system, drain valve 50 mm diameter shall be provided down stream of Installation Control Valve or any subsidiary stop valve.

A common valve can perform the functions of test and drain. The outlet shall be connected with a 50 mm diameter G.I. drain pipe along with riser pipes as shown in figure No. 3 and 4.

9.4.12.3 **Flushing Valve:-** If the water used for sprinkler is not potable, flushing valves shall be provided at the end of a distribution pipe. The valve size shall be same as distribution pipe. Valve outlet shall be fitted with a brass plug and extended to not more than 3 m above floor.

9.4.12.4 **Check Valve:-** Check valve shall be provided where more than one water supply is available and same shall be fitted on each water supply pipe.

9.4.12.5 **Subsidiary Stop Valve:-** Subsidiary stop valve which shall be of the same diameter as the pipe line in which they are fitted shall be provided to control water supply to sprinklers of highly sensitive areas like computer rooms.

9.4.12.6 **Installation Control Valve (ICV):** - A sprinkler installation shall be fitted with a suitable Installation Control Valve to control the water supply to the installation. The valve set shall comprise of:

- (a) a main stop valve.
- (b) an alarm valve.
- (c) a water motor alarm.

The alarm valve shall be fitted immediately downstream of the main stop valve of each building/block and before any connection is taken off to supply any part of the installation.

The Installation Control Valve shall be placed externally in the vicinity of the main entrance of the building protected at an easily accessible place so that the alarm bell sound is heard by the inhabitants/passers-by. The valve shall be secured open by a pad locked or rivetted strap and protected against impact damage.

If there are genuine constraints in locating the Installation Control Valve

outside the buildings, this may be located inside the building in the vicinity of main entrance (subject to approval of authorities concerned). Installation Control Valve in such cases, shall be located away from any exposure to damage and personnel shall be normally available in the vicinity of the location to get alerted by alarm operation. Also, electrically operated sirens interfaced with the opening of the alarm valve of ICV, shall be provided outside the building. In no case, Installation Control Valve shall be provided inside basement or inside pump room.

A plan of the risk with the position of Installation Control Valve shall be placed in a conspicuous location. A location plate shall be fixed near the Installation Control Valve bearing the following words in raised letters:

**SPRINKLER
ALARM VALVE**

9.4.12.7 Water motor alarm: Water motor alarm shall be provided very close to the alarm valve. Strainer shall be fitted between the alarm valve and the motor nozzle connection. The water outlet shall be positioned so that any flow of water can be seen. The alarm device shall provide audibility level of 85 dB above the back ground noise level.

9.4.12.8 Pressure Gauges: - Pressure gauges shall be provided immediately above and below each alarm valve.

Stop cock shall be provided before pressure gauges for removal without interruption of water supply of the installation. Pressure gauges shall be as per IS: 3624.

9.5 SPRINKLERS TYPE

Sprinklers shall be as per IS: 9972 and following types:

9.5.1 According to type of discharge (*Refer Figure - 15*):

- a) Conventional pattern
- b) Spray pattern
- c) Side wall pattern

9.5.2 According to mounting pattern:

- a) Pendent sprinkler
- b) Up right sprinkler
- c) Horizontal sprinkler
- d) Ceiling sprinkler

9.5.3 According to Release Mechanism:

- a) Fusible element sprinkler
- b) Glass bulb sprinkler

9.5.4 According to Orifice Size:

- a) 10 mm
- b) 15 mm
- c) 20 mm
- d) 25 mm

9.5.5 According to Temperature Rating:

Sprinkler shall have one of the following temperature rating and shall be correspondingly color coded:

(a) Fusible Link Type	Temp. Rating °C	Color Code
	68/74	Natural
	93/100	White
	141	Blue
	182	Yellow
	227	Red
(b) Glass Bulb Type	Temp. Rating	Color of bulb Liquid
	57	Orange
	68	Red
	79	Yellow
	93	Green
	141	Blue
	182	Mauve
	204/260	Black

9.6 SELECTION OF TEMPERATURE RATING

Temperature rating of a sprinkler should not be less than 30° C more than the highest anticipated temperature of the location of installation. Under glazed roofs or where there are roof sheets of PVC or similar plastic material,

sprinkler shall be rated 73° C to 100° C.

9.7 SELECTION OF ORIFICE SIZE

In moderate hazard applications, sprinklers of orifice size 15 mm shall be used.

S. No.	HAZARD CLASS	SPRINKLER PATTERN	NOMINAL ORIFICE NOT LESS THAN MM
(1)	(2)	(3)	(4)
i)	Light	Standard, Spray, Flush, Sidewall types	10-15
ii)	Ordinary	All except sidewall types	15
iii)	High	Standard, spray pattern only	15-25
iv)	Storage	Standard, spray pattern only	15-25

9.8 SIZE OF INSTALLATIONS

The protected floor area to be controlled by any one Installation Control Valve shall not exceed 12000 m².

As far as possible one area shall be controlled by one Installation Control Valve. If the area is quite large, more than one Installation Control Valve should be planned. Details of area controlled by an Installation Control valve shall be exhibited near it.

If there are more than one block in a campus, each block shall be provided with different Installation Control valve.

9.9 PROTECTION OF SPRINKLERS

Any sprinkler installed in a position of risk or accidental damage shall be fitted with a metal guard suitable for sprinkler service.

9.10 WATER SUPPLY ARRANGEMENT FOR SPRINKLER

9.10.1 Pump- Details of pumps to be installed for sprinkler installation are given in Appendix-A. For large installations, separate jockey pump shall be provided for sprinkler system. All pumps shall have common discharge header. If two electrical pumps are to be provided one non-return valve shall be provided in the header such that sprinkler pump will not feed

other system.

- 9.10.2 Water Storage Tank- The water storage tank shall be combined for other firefighting system and sprinkler installation and the capacity shall be as given in Appendix 'A'.

9.11 SPRINKLER ANNUNCIATION PANEL AND ALARM

Electrically operated alarm shall be provided for indication of operation of sprinkler in an area. Water flow switches shall be installed in main distribution pipes which shall be wired to sprinkler annunciation panel. In the event of operation of a sprinkler, the flow switch will operate and give signal to the annunciation panel to indicate operation of sprinkler in the area. This will initiate an electrically operated alarm. The system shall be independent of fire alarm system and compatible with BMS. Necessary potential free contacts for use in BMS should be provided.

9.11.1 Construction Details

- (i) The Panel shall be fabricated out of not less than 2 mm thick MS sheet and powder coated after 7 tank treatment process and shall be totally enclosed dust damp and vermin proof. Suitable knockout shall be provided for the entry of cables. The panel shall be designed such that the equipment for power supply, battery charging are housed in independent compartments. Sealed maintenance free batteries shall also be accommodated inside the panel.
- (ii) Indicating lamps control switches, buttons and fuses shall be suitably located in the front and properly labeled.
- (iii) The indicating lamps shall be LED type of following colors. The flow switch operation conditions shall be indicated by twin lamps.
 - (a) Red to indicate flow switch operation.
 - (b) Amber to indicate fault condition.
 - (c) Green to indicate healthy condition.
- (iv) The test buttons to test the indication lamps shall be provided.
- (v) The panel control shall be microprocessor type.
- (vi) The primary function of the panel shall be to respond automatically to the operation of one or more flow switches to give alarm and to indicate area/areas where the device has activated. The operation of one or more flow switches shall result in simultaneous alarm given by the following:-
 - (a) External alarm hooter(s) (provided outside the building to be protected).
 - (b) A visible indication on panel.

- (c) Audible alarm on panel itself (common for all zones)
- (vii) The panel shall indicate the fault within the system and immediate fault warning shall be given by an audible and visible signal on the panel in case of open circuit, short circuit and earth fault in cable between flow switch and annunciation panel.
- (viii) The panel shall be complete with mimic diagram for the areas covered by different flow switches. The layout of mimic diagram shall be got approved from Engineer- in-Charge.
- (ix) Battery backup with trickle cum boost charger shall be provided for operation of the system. Indication of mains failure and the state of charge of the batteries shall be provided. The batteries shall be sealed maintenance free. The capacity of the battery shall be 12 Volt, 2 Nos. 24 Ah each. All standard accessories shall be provided.

9.12 INSTALLATION

The installation shall be carried out as per Chapter 7 and 11. Following additional points are to be taken care for sprinkler installations:

- 9.12.1 For fixing sprinkler heads, 15 mm diameter M.S. Socket is to be welded to range pipes at the locations as per drawings. Dead plug shall be fixed in the socket.
- 9.12.2 If sprinkler head is to be provided away from range pipe, M.S. Pipe nipple of suitable size be used to extend the sprinkler head and socket is welded at desired location.
- 9.12.3 After completion of work in sections, pressure testing at 7.5 kgf/cm² pressure shall be carried out for 24 hrs.
- 9.12.4 After completion of the entire work, pressure testing of entire pipe work shall be carried out for 24 hrs. at a pressure of 7.5 kgf/cm². The drop of pressure up to 0.5 kgf/cm² shall be accepted.
- 9.12.5 The lines shall be flushed before completion of building work so that any foreign matter which might have entered the system is taken out. The pressurization pump (Jockey Pump) be operated and valves opened at different locations.
- 9.12.6 During occupation of the building, sprinkler heads shall be provided in place of dead plugs. Teflon tape shall be used on threaded portion. The sprinkler heads shall be properly tightened in the socket.
- 9.12.7 When all sprinklers heads are installed, pressure is built up in the system by

pressurization pump slowly and in case no leak is found, desired pressure is developed and maintained. In case any leak is detected, the same shall be attended before pressurizing the system further.

9.13 COMMISSIONING

As soon as the work is complete, the system shall be commissioned and made available for use in accordance with Para 11.6.

9.14 Spare Sprinklers to be Kept in Stock :

A stock of spare sprinklers shall be maintained in the premises so that prompt replacement is possible after the operation/damage of sprinkler heads. The spares shall be kept in an easily accessible location under conditions where the temperature does not exceed 38°C.

The guidelines as in Table 9.7 shall be followed in respect of stocking spare sprinkler heads.

Spanners or wrenches for the sprinklers shall also be kept along with the spare sprinklers in readiness.

Table 9.7

Guidelines for stocking spare sprinkler			
S. No.	HAZARD CLASS	All state capitals and within 200Km thereof	Other locations
(1)	(2)	(3)	(4)
i)	Light	5 sprinklers of each type	15
ii)	Moderate/Ordinary	15 sprinklers of each type	25
iii)	High & storage	30 sprinklers of each type	50
<p>Note- When there is more than one installation within a complex, the above quantity shall also be increased in proportion. Each type of sprinkler used in the installation such as conventional or spray or ceiling/flush or sidewall sprinklers and appropriate temperatures shall be stocked as per the above requirements.</p>			

CHAPTER-10

ELECTRICAL WORK

10.1 SCOPE

This chapter covers the requirements for the electrical works associated with firefighting installations, namely, motors, switch boards, power cabling, control wiring, earthing and remote control-cum-indicating panels.

10.2 GENERAL

- (i) Unless otherwise specified in the tender specifications, all equipment and materials for electrical works shall be suitable for operations on 415 V / 240 V + 10% (3 phase/single phase), 50 Hz AC system.
- (ii) All electrical works shall be carried out complying Central Electricity Authority (Measures Relating To Safety and Electric Supply) Regulations, 2010 and NEC 2011, as amended up to date.
- (iii) All parts of electrical works shall be carried out as per appropriate CPWD General Specifications for Electrical works, namely, Part I (Internal) 2013, Part II (External) 1994 work, and Part IV (Sub-station)- 2013 all as amended up to date.
- (iv) All materials and components used shall conform to the relevant IS specifications amended to date.

10.3 POWER SUPPLY

Power supply to following systems and equipment, where provided, shall be from normal and emergency (standby generator) power sources with change over facility:

- a) Fire pumps
- b) Pressurization and smoke venting; including its ancillary systems such as dampers and actuators.
- c) Terrace pump
- d) Fireman's lifts (including all lifts).
- e) Exit signage lighting.
- f) Emergency lighting.
- g) Fire alarm system.
- h) Public address (PA) system (relating to emergency voice evacuation and annunciation).
- i) Magnetic door hold open devices.
- j) Lighting in fire command center and security room.

The generator shall be capable of taking starting current of all the fire and life safety systems and equipment as above. Where parallel HV/LV supply from a

separate substation fed from different grid is provided with appropriate transformer for emergency, the provision of generator may be waived in consultation with the Authority.

The electric supply to the pumping set(s) shall be entirely independent of all other equipment in the premises that is even when the power throughout the entire premises is switched off, the supply to the pump shall continue to be available un-interrupted. This can be achieved by taking the connection for the pump(s) from the incoming side of the main L.T. breaker. In case, where parallel HV/LV supply from a separate substation fed from different grid is provided with appropriate transformer for emergency connected to a common bus bar, the connection may be taken through the bus bars.

The power supply to the panel/distribution board of these fire and life safety systems shall be through fire proof enclosures or circuit integrity cables or through alternate route in the adjoining fire compartment to ensure supply of power is reliable to these systems and equipment. It shall be ensured that the cabling from the adjoining fire compartment is protected within the compartment of vulnerability. The location of the panel/distribution board feeding the fire and life safety system shall be in fire safe zone ensuring supply of power to these systems.

Circuits of such emergency system shall be protected at origin by an automatic circuit breaker so set as to permit the motor to be overloaded during an emergency to the maximum limit permissible by the manufacturer. Further, the no volt coil/the under voltage release of that circuit breaker shall be removed. Master switches controlling essential service circuits shall be clearly labeled.

- 10.3.1 Independent supply shall be provided for water supply pumps if installed in the same pump house.
- 10.3.2 If the fire pump house is away from the sub-station building, the route of the cable shall not pass under the building or permanent structure. Cable shall be laid along the route which is safe from fire.
- 10.3.3 Sufficient spare power shall always be available to drive pumping sets at all times throughout the year. Suitable capacity ACBs/SDFUs shall be provided in the electrical panel for extending supplies to fire pumps. Such switches shall be suitably marked "FIRE SWITCH" and shall not be switched-off without permission/intimation to appropriate authority. In case any maintenance/repair work is to be carried out on the electrical panel where

from supplies to fire pumps have been extended, alternative arrangement shall be made to ensure that power supply to fire pumps continue to be available for operation any time.

10.4 MOTORS

The motors shall be squirrel cage AC induction type. The motors shall be suitable for continuous duty and rating necessary to drive the pump at 150 percent of its rated discharge with at least 65 percent rated head. The motor shall be totally enclosed fan cooled type conforming to protection clause IP 21 of IS: 4691. The class of insulation shall be 'F'. The synchronous speed shall be 1500/3000 rpm as per requirement of the pump. The motor shall conform to IS:325.

10.5 MOTOR STARTER

- (i) The motor starter shall conform to IS: 1822 "Motor starters of voltage not exceeding 1000 volts" and shall be air insulated and suitable for 415 V, \pm 10%, 50 Hz, 3 phase AC supply and shall be integrated in the panel.
- (ii) Starter for the motor shall be direct on line (D.O.L) for motors up to and including 7.5 H.P. rating and automatic star-delta type for motors of higher ratings unless otherwise specified in the tender specifications. However, for main Fire Pump & Sprinkler Pump Soft Starters may be used.
- (iii) Each starter shall be provided with the following protections: -
 - (a) Thermal overload on all the three phases with adjustable settings,
 - (b) Independent single phase preventer. (Current sensing type).
- (iv) Adequate number of extra NO/NC contacts for interlocks, indicating lamps, remote operation etc. shall be provided on the starter/contactors.
- (v) Under voltage/No volt trip shall not be provided.

10.6 SWITCH BOARDS

- (i) The main switch board shall be floor mounted, free standing or wall mounted cubical type and shall be factory built fabricated by one of the approved switch board manufacturer. The board shall be fabricated from 2.0 mm thick CRCA sheet and powder coated after 7 tank treatment process. The board shall be fabricated with IP 42 degree of protection. It shall be suitable for termination of the incoming cable(s) from bottom.
- (ii) The capacity of switch gear shall be suitable for the requirements of motor fed/ controlled. Starting currents shall be duly considered.
- (iii) Switch fuse units shall be used up to and including 32 A and SDFU shall be used for 63 A and above. ACB shall be used for 630 A and above ratings.
- (iv) All Switch fuse units/SDFUs shall be of AC 23 duty as per IS: 4064-1978 as amended up to date. They shall be complete with suitable HRC cartridge type fuses.
- (v) Switch boards shall house starters for motors with independent current sensing

- type single phase preventor for each starter.
- (vi) Volt meter with selector switch, a set of indicating lamps and fuses for voltmeter and lamps shall be provided. Ammeter with CTs, and selector switch shall be provided with each motor starter. Instruments shall be flush mounted with the panel and have a class index not higher than 1.0. The instruments and accessories shall be provided whether or not specifically indicated in the tender specifications.
 - (vii) The fabrication of switchboard shall be taken up only after the drawings for the fabrication of the same are approved by the Engineer-in-charge.
 - (viii) Switchboards shall be fabricated as per specifications indicated in sub-para above.
 - (ix) The layout shall be designed for convenient connections and inter-connections with the various switchgear. Connections from individual compartments to cable alleys shall be such as not to shut down healthy circuits in the event of maintenance work becoming necessary on a defective circuit.
 - (x) Care shall be taken to provide adequate clearances between phase bus bars as well as between phase bus bars, neutral and earth.
 - (xi) Where terminations are done on the bus bars by drilling holes therein, extra cross section shall be provided for the bus bars. Alternatively, terminations may be made by clamping.
 - (xii) Provision shall be made for proper termination of cables at the switchboards such that there is no strain either on the cables, or on the terminators. Cables connected to the upper tiers shall be duly clamped within the switchboard.
 - (xiii) Identification labels shall be provided against each switchgear and starter compartment, using plastic/aluminum engraved labels.
 - (xiv) Metallic danger board conforming to relevant IS shall be fixed on each electrical switchboard.

10.7 SYSTEM CONTROLLER

For controlling operation of pumps as per Para 2.4.1.14 and indicating fault, system controller shall be provided. The system controller shall consist of relays, timer, contactors etc. and shall be designed to operate the fire pumps with interlocking and fault indication as described in Para 2.4.1.15. Annunciation window shall be provided to indicate following faults:

- (i) Low water level in UG tank
- (ii) Low water level in terrace tank.
- (iii) Main pump failed to start.
- (iv) Main pump failed during operation.
- (v) Diesel pump failed to start.
- (vi) Diesel pump failed during operation
- (vii) Supply to Main Pump failed
- (viii) Supply to Pressurization Pump failed

- (ix) Supply to Terrace Pump failed.

Suitable sensors, differential pressure switches, monitors shall be provided at respective locations. The control system shall be operational on 12 Volt/24 Volt DC starting batteries of engine. Battery chargers shall be provided to ensure that the batteries remain charged. Batteries shall be sealed maintenance free type.

10.8 REMOTE INDICATING PANEL

- (i) The remote indicating panel shall be provided in the fire control room. This panel shall have necessary status indication of all electric motors.
- (ii) Back indication to show the status of operation of all the motors, pressure in the system, water level in underground and overhead tank etc. shall be provided.
- (iii) Panel shall be fabricated from not less than 1.6 mm thick CRCA sheet and powder coated after 7 tank treatment process. The panel shall be dust, damp and vermin proof. This shall be of wall mounting type. This shall be complete with necessary termination arrangements, multicore cables, tag blocks, control transformer, designation plastic labels, double earth studs etc. as required.

10.9 POWER CABLING

- (i) Unless otherwise specified, the power cables shall be XLPE insulated, PVC outer sheathed aluminum conductor, armoured cables 1100 V grade. The power cables shall be of 2 core for single phase, 4 core for sizes up to and including 25 sq.mm for 3 phase and 3-1/2 core for sizes higher than 25 sq.mm for 3 phase.

Alternatively, XLPE/PVC insulated copper cable (single core/multicore armoured/un-armoured) of grade 1100 V shall be used.

For main power cable(s) from LT Room to Fire Pumps Panel, if the cable(s) is taken in cable trench duly filled with sand & with proper distancing from other cables within the cable trench, or in fire rated shaft, then the cable(s) of above type be used. However, if the cable(s) is likely to be exposed to fire, then fire survival cable(s) shall be used.

- (ii) Power cables shall be of sizes to meet the starting and running current of motors fed and shall be as approved by the Engineer-in-Charge, after taking into consideration the load, the length of cabling.
- (iii) Cables shall be laid in suitable metallic trays suspended from ceiling, or mounted on walls. Cable ducts shall not be provided in pump rooms. Cable trays shall be of perforated steel sheet with adequate structural strength and rigidity. Necessary supports and suspenders for cable trays shall be provided by the contractor as required.

10.10 CONTROL WIRING

- (i) Control wiring shall be done using ISI marked PVC insulated and PVC sheathed, 2.5 sq.mm, 250 V grade, armoured multi-core copper conductor cable. The control cable shall also be laid in the same manner as power cable.
- (ii) The number and size of the control cables shall be such as to suit the control system design adopted by the contractor.
- (iii) Runs of control wires within the-switchboard shall be neatly bunched and suitably supported/clamped. Means shall be provided for easy identification of the control wires.
- (iv) Control wiring shall correspond to the circuitry/sequence of operations and interlocks approved by Engineer-in-Charge.

10.11 EARTHING

- (i) Provision of earth electrodes and the type of earthing shall be as specified in the tender specifications.
- (ii) The earth work shall be carried out in conformity with CPWD Specifications for Electrical works (Part-I), Internal 2013.
- (iii) Metallic body of all motors, medium voltage equipment and switch boards shall be connected by two separate and distinct earth conductors to the earth stations of the installations. Looping of such body earth conductors is acceptable from one equipment, or switch board to another.
- (iv) The size of earth conductors for body earthing of equipment shall be 2 Nos. 6 mm dia copper wire/2 Nos. 25 x 3 mm G.I. strip
- (v) Armoring of cables shall be connected to the body of the equipment/switch board at both the ends. Compression type glands shall be used for all such terminations in the case of PVC/XLPE cables.

10.12 PAINTING

All panels shall be supplied with the manufacturer's standard finish painting or as indicated in the Schedule of Work.

CHAPTER-11

INSTALLATION, TESTING AND COMMISSIONING

11.1 SCOPE

This chapter covers the requirement of Installation, testing and commissioning of firefighting system.

11.2 PREPARATION AND APPROVAL OF DRAWING

On award of the work, the contractor has to prepare working drawings as per Para 1.17.2 and submit to the Engineer-in-charge for approval. The work is to be executed as per approved drawings. The stage of approval of drawings is therefore very important. All drawings should be carefully and critically examined before approval. The requirements of various components of firefighting system have been described in previous chapters dealing with the components. However, generally following points are to be taken care while examining and approving the drawings.

11.2.1 Site survey should be carried out in detail.

11.2.2 In addition to building plans, layout plan along with landscape plan/horticulture plan and other services plans should be consulted while deciding route of underground pipes from pump house and around the building.

11.2.3 As far as possible, underground pipe are not to be laid under road, pavement, building and long open spaces. The locations along road, foot path in earth may be preferred.

11.2.4 The location of yard hydrants, fire service inlet and fire service connection are to be decided based on consideration of Para 2.4.1.8 to Para 2.4.1.10. However necessary adjustments are to be made so that these components do not become hindrance in vehicular movement and entrance to the building. Requirement of other building services are also to be given due consideration. Symmetry should be maintained for aesthetic considerations.

11.2.5 Pipe sizes are to be decided in accordance with provision of Para 2.4.1.2 and 4.5.4.

11.2.6 Pump House:-The layout of equipment in pump house is very important from operation and maintenance considerations. The requirement of pumps and engine have been described in Chapter 5 and 6. In case other equipment i.e.

water supply pumps etc. are to be installed in the same pump house, sufficient space shall be left for them as well. The dimensioned foundation drawing of pumps should be available for marking in the pump room layout. The layout is to be prepared in such a way that it should be possible to maintain any equipment without disturbing the adjoining equipment. Electrical panels are to be installed at a location which is easily accessible near the entrance to the pump house and there should be no possibility of water dripping over or near the electrical panel. Typical layout of fire pump house is shown in Figure -10.

11.2.7 Terrace Pumps:- The location of pumps and terrace pipe may be decided keeping in view location of terrace tanks for firefighting and other services. The pipe line should not cause undue hindrance for movement of maintenance personnel at the terrace.

11.2.8 Electrical Panel :- Complete wiring drawing, layout etc. are to be examined to ensure that provisions of agreement are incorporated in the drawing. Sizes of various panel and mounting arrangement may be decided keeping in view ease of operation and aesthetic consideration as well.

11.3 INSTALLATION:-

The requirements of installation of various components have been described in previous chapters. However, following precautions are to be taken during execution of the work.

11.3.1 The pump and motor/engine are to be perfectly aligned on the base plate so that there is no vibration during operation. All nuts, bolts, washers shall be of adequate size and galvanized.

11.3.2 The pipe supports should be decided in a way that the weight of pipes and valves are not transferred to the pumps and supports do not cause hindrance in movement inside the pump house. As far as possible, floor supports may be provided in pump house.

11.3.3 All valves shall be installed at a height and in a position that their operation by right hand is conveniently possible.

11.3.4 All pressure gauges should be installed so that the dial is vertical and is visible while entering the pump house.

11.3.5 Electrical panels should not be installed at floor level. The panels shall be sufficiently raised above ground level. If panels are to be mounted on wall, an angle iron frame shall be provided so that at least 75 mm space is left

behind the panels. The panels shall be easily approachable.

- 11.3.6** Cable trays are to be used for laying of power and control cable inside pump house. No cable is to be laid at floor level/in trench. Cable tray layout should give neat appearance. All cable tray shall be adequately supported from the ceiling/floor.
- 11.3.7** Drain pump shall be installed in the sump provided as per Para 3.2.2 (viii). The pump shall operate automatically for which water level sensor shall be provided.
- 11.3.8** In no case any structural member i.e. RCC wall, column, beam and floor are to be damaged during installation. Mechanical fasteners are to be used for grouting support.
U.G. tank wall is not to be used for any support. No pipe/cable is to cross the pump house below ground level. Openings above ground level are only to be used for this purpose.
- 11.3.9** The engine installation work shall be carried out in accordance with the requirement of engine manufacturer and be got approved by the manufacturer or their authorized service center. The exhaust pipe should be suitably extended outside the pump house so that smoke does not effect nearby structure. Fuel tank shall be properly supported and located in a way that the same does not cause hindrance in movement in the pump house.
- 11.3.10** While excavating for laying of external pipes, suitable sign board/ barricading shall be provided to ensure that no person falls in the trench.
- 11.3.11** The width and depth of trench shall be adequate for laying the pipe 1m below ground level.
- 11.3.12** No earth or any other matter is to be allowed to enter the pipes. The ends shall be kept closed always.
- 11.3.13** The anticorrosive treatment is to be applied on the entire length laid underground in accordance with Para 7.5. The treatment is not to be damaged.
- 11.3.14** Pressure testing is to be carried out in sections before filling the earth back in the trench.
- 11.3.15** The earth filling is to be done in layers of 20 cm each and properly rammed

so as to avoid possibility of settlement. Surplus earth/malba shall be removed from the site by the contractor.

- 11.3.16** Where pipes crossing road likely to have heavy traffic, additional protection over pipe shall be provided to ensure that pipe is not damaged. However, semi-circular RCC Pipes shall be provided over cast iron pipes at road crossings.
- 11.3.17** External hydrants and fire service connection/ inlet shall be located parallel to the nearby road/ foot path so as to give proper appearance. Foundation shall be raised from below ground level and shall be properly plastered in plumb. The hydrants shall be facing the road/ approach. There shall be no obstruction in approaching the hydrants for operation.
- 11.3.18** Risers shall be parallel to the wall and in plumb. Adequate supports shall be provided from the wall. Opening around the pipe in slab shall be filled with CC and finished with plaster.
- 11.3.19** Internal hydrant shall be provided in the center and facing outside for ease of operation. Sufficient space shall be provided around the handle for operation. There shall be no hindrance in moving the first aid hose reel.
- 11.3.20** Terrace pipes shall be supported on CC pedestals of adequate height. The pipe route shall be such as no hindrance is created in movement at the terrace. Pipes shall be sufficiently raised above terrace. It is to be ensured that water proofing is not damaged during laying of pipes.

11.4 TESTING

11.4.1 Initial Testing

- 11.4.1.1 During laying of pipes, the same shall be subjected to 10 kgf/cm² hydraulic pressure for a period of 24 hours, in sections.
- 11.4.1.2 After completion of the work, all valves/ fittings shall be installed in position and entire system shall be tested for 24 hours at a pressure of 10 kgf/ cm². The drop of pressure up to 0.5 kgf/cm² shall be accepted.

11.4.2 Final Testing

- 11.4.2.1 After completion, all operation checks as per Para 2.4.1.14 shall be carried out for automatic operation of the systems. For this purpose, landing valves may be opened at different locations. The exercise shall be repeated couple of times to ensure trouble free operation of the system.

11.4.2.2 **Flow Test:** - The design flow of pumps shall be checked. The pump shall be operated after opening a number of landing valves at different locations. Design pressure is to be maintained in the pump house. Water discharge is to be measured by drop in level in UG tank for a certain period. All pumps shall be tested one by one. The flow rate shall be not less than as specified while maintaining the design pressure in pump house.

11.5 INSPECTION BY LOCAL FIRE OFFICER

After completion of the work and testing to the entire satisfaction of Engineer-in-Charge, the installation shall be offered for inspection by Chief Fire Officer or his representative. Testing as desired by the Fire Officer shall be carried out. The contractor will extend all help including manpower during testing. The observations of Chief Fire Officer shall be part of the agreement. These shall be attended by the contractor. Nothing extra shall be paid for testing as above.

11.6 COMMISSIONING

11.6.1 Flushing the System: Before commissioning, the entire system shall be flushed to ensure that any earth/ foreign matters which might have entered during installation are taken out. For this, pump may be operated and valves opened at different locations.

11.6.2 As soon as the work is complete, the system shall be commissioned and made available for use. Requirement of firefighting installations is equally important during occupation of the building. If the building is to be occupied in part, firefighting system of building completed shall be commissioned by isolating the system of under construction portion of the building.

11.6.3 The firefighting system shall be maintained and manned from the very first day of its commissioning.

11.6.4 Any defects noticed during the warranty period shall be promptly attended by the contractor and availability of the system at all time is to be ensured.

Appendix-A: Minimum Requirements for Firefighting Installations (Based on Table 7 of Vol-1, Part-4 of NBC 2016)

Sl. No.	Type of Building Occupancy	Type of Installation								Water Supply (litre)		Pump capacity (litre/min)	
		Fire Extinguisher	First Aid Hose Reel	Wet Riser	Down Comer	Yard Hydrant	Automatic Sprinkler System	Manually Operated Electronic Fire Alarm System (see Note 1)	Automatic Detection and Alarm System (see Note 2)	Under-ground Static Water Storage Tank Combined Capacity for Wet Riser, Yard Hydrant and Sprinklers per set of pumps	Terrace Tank over Respective Tower Terrace	Pump Near Underground Static Water Storage Tank (Fire Pump) with Minimum Pressure of 3.5kgf/cm ² at Remotest Location	At the Terrace Tank Level with Minimum Pressure of 3.5kgf/cm ²
(1)	(2)	(3)	(4)	(5)	(6)	(7)	(8)	(9)	(10)	(11)	(12)	(13)	(14)
RESIDENTIAL BUILDINGS(A)													
a)	Lodging and Rooming Houses (A-1) (see Note 3)												
1)	Less than 15 m in height												
	i) Up to 15 rooms	R	NR	NR	NR	NR	R (see Note 4)	NR	NR	NR	5000 (see Note 5)	NR	NR
	ii) More than 15 and up to 30 rooms	R	R	NR	NR	NR	R (see Note 4)	NR	NR	NR	5000 (5000) (see Note 6)	NR	450 (450) (see Note 6)
	iii) More than 30 rooms	R	R	NR	NR	NR	R (see Note 4)	R (see Note 7)	NR	NR	10000 (5000) (see Note 6)	NR	450 (450) (see Note 6)
b)	One or two Family Private Dwellings (A-2) (see Note 3)	NR	NR	NR	NR	NR	NR	NR	NR	NR	NR	NR	NR

Appendix-A - (Continued)

Sl. No.	Type of Building Occupancy	Type of Installation								Water Supply (liter)		Pump capacity (liter/min)	
		Fire Extinguisher	First Aid Hose Reel	Wet Riser	Down Comer	Yard Hydrant	Automatic Sprinkler System	Manually Operated Electronic Fire Alarm System (see Note 1)	Automatic Detection and Alarm System (see Note 2)	Under-ground Static Water Storage Tank Combined Capacity for Wet Riser, Yard Hydrant and Sprinklers per set of pumps	Terrace Tank over Respective Tower Terrace	Pump Near Underground Static Water Storage Tank (Fire Pump) with Minimum Pressure of 3.5kgf/cm ² at Remotest Location	At the Terrace Tank Level with Minimum Pressure of 3.5kgf/cm ²
(1)	(2)	(3)	(4)	(5)	(6)	(7)	(8)	(9)	(10)	(11)	(12)	(13)	(14)
c)	Dormitories (A-3) and Apartment Houses (A-4)												
1)	Less than 15 m in height	R	R	NR	NR	NR	R (see Note 4)	NR	NR	NR	5000 (5000) (see Note 6)	NR	450 (450) (see Note 6)
2)	15 m and above but not exceeding 35 m in height	R	R	NR	R	NR	R (see Note 4)	R (see Note 8)	NR	NR	25000	NR	900
3)	Above 35 m but not exceeding 45 m in height	R	R	R	NR	NR	R (see Note 4 and Note 9)	R	NR	75000	5000	(see Note 10)	NR
4)	Above 45 m in height but not exceeding 60 m in height	R	R	R	NR	R	R	R	NR	150000	10000	(see Note 11)	NR
5)	Above 60 m in height	R	R	R	NR	R	R	R	R	200000	10000	(see Note 12 & Note 13)	NR
Educational Buildings(B) (see Note 16)													
1)	Less than 15 m in height												

Appendix-A - (Continued)

Sl. No.	Type of Building Occupancy	Type of Installation								Water Supply (liter)		Pump capacity (liter/min)	
		Fire Extinguisher	First Aid Hose Reel	Wet Riser	Down Comer	Yard Hydrant	Automatic Sprinkler System	Manually Operated Electronic Fire Alarm System (see Note 1)	Automatic Detection and Alarm System (see Note 2)	Under-ground Static Water Storage Tank Combined Capacity for Wet Riser, Yard Hydrant and Sprinklers per set of pumps	Terrace Tank over Respective Tower Terrace	Pump Near Underground Static Water Storage Tank (Fire Pump) with Minimum Pressure of 3.5kgf/cm ² at Remotest Location	At the Terrace Tank Level with Minimum Pressure of 3.5kgf/cm ²
(1)	(2)	(3)	(4)	(5)	(6)	(7)	(8)	(9)	(10)	(11)	(12)	(13)	(14)
	i) Ground plus one or more storey	R	R	NR	NR	NR	R (see Note 4)	NR	NR	NR	10000 (5000) (see Note 6)	NR	450 (450) (see Note 6)
2)	15 m and above but not exceeding 24 m in height	R	R	NR	R	NR	R (see Note 4)	R	NR	NR	25000	NR	900
3)	Above 24 m but not exceeding 30 m in height	R	R	R	NR	R	R (see Note 4)	R	NR	50000	(5000) (see Note 6)	(see Note 14)	NR
INSTITUTIONAL BUILDINGS(C) (see Note 16)													
a)	Hospitals, Sanatoria and Nursing Homes (C-1)												
1)	Less than 15 m in height with plot area up to 1000 m ²												
	i) Up to ground plus one storey, with no beds	R	NR	NR	NR	NR	R (see Note 4)	R	NR	NR	(5000) (see Note 6)	NR	(450) (see Note 6)
	ii) Up to ground plus one storey with beds	R	R	NR	NR	NR	R (see Note 4)	R	NR	NR	5000 (5000) (see Note 6)	NR	450 (450) (see Note 6)

Appendix-A - (Continued)

Sl. No.	Type of Building Occupancy	Type of Installation								Water Supply (liter)		Pump capacity (liter/min)	
		Fire Extinguisher	First Aid Hose Reel	Wet Riser	Down Comer	Yard Hydrant	Automatic Sprinkler System	Manually Operated Electronic Fire Alarm System (see Note 1)	Automatic Detection and Alarm System (see Note 2)	Under-ground Static Water Storage Tank Combined Capacity for Wet Riser, Yard Hydrant and Sprinklers per set of pumps	Terrace Tank over Respective Tower Terrace	Pump Near Underground Static Water Storage Tank (Fire Pump) with Minimum Pressure of 3.5kgf/cm ² at Remotest Location	At the Terrace Tank Level with Minimum Pressure of 3.5kgf/cm ²
(1)	(2)	(3)	(4)	(5)	(6)	(7)	(8)	(9)	(10)	(11)	(12)	(13)	(14)
	iii) Ground plus two or more storey, with no beds	R	R	NR	R	NR	R (see Note 4)	R	R	NR	10000 (5000) (see Note 6)	NR	900 (450) (see Note 6)
	iv) Ground plus two or more storey, with beds	R	R	R	NR	NR	R	R (see Note 1)	R	75000	10000	(see Note 14)	NR
2)	less than 15 m in height with plot area more than 1000 m ²	R	R	R	NR	R	R	R (see Note 1)	R	100000	10000	(see Note 14)	NR
3)	15 m and above but not exceeding 24 m in height	R	R	R	NR	R	R	R	R	150000	20000	(see Note 10)	NR
4)	Above 24 m and not exceeding 45 m in height	R	R	R	NR	R	R	R	R	200000	20000	(see Note 11)	NR
b)	Custodial (C-2), and Penal and Mental (C-3)												
1)	Less than 10 m in height												

Appendix-A - (Continued)

Sl. No.	Type of Building Occupancy	Type of Installation								Water Supply (liter)		Pump capacity (liter/min)	
		Fire Extinguisher	First Aid Hose Reel	Wet Riser	Down Comer	Yard Hydrant	Automatic Sprinkler System	Manually Operated Electronic Fire Alarm System (see Note 1)	Automatic Detection and Alarm System (see Note 2)	Under-ground Static Water Storage Tank Combined Capacity for Wet Riser, Yard Hydrant and Sprinklers per set of pumps	Terrace Tank over Respective Tower Terrace	Pump Near Underground Static Water Storage Tank (Fire Pump) with Minimum Pressure of 3.5kgf/cm ² at Remotest Location	At the Terrace Tank Level with Minimum Pressure of 3.5kgf/cm ²
(1)	(2)	(3)	(4)	(5)	(6)	(7)	(8)	(9)	(10)	(11)	(12)	(13)	(14)
	i) Up to 300 persons	R	R	NR	NR	NR	R (see Note 4)	R	NR	NR	10000 (5000) (see Note 6)	NR	450 (450) (see Note 6)
	ii) More than 300 persons	R	R	NR	R	NR	R (see Note 4)	R	NR	NR	15000 (5000) (see Note 6)	NR	900 (450) (see Note 6)
2)	10 m and above but not exceeding 15 m in height	R	R	R	NR	R	R (see Note 4)	R	R	100 000	5000 (5000) (see Note 6)	(see Note 10)	NR
3)	15 m and above but not exceeding 24 m in height	R	R	R	NR	R	R	R	R	150000	10 000	(see Note 11)	NR
4)	24 m and above but not exceeding 30 m in height	R	R	R	NR	R	R	R	R	200000	20 000	(see Note 11)	NR
ASSEMBLY BUILDINGS (D) (see Note 16)													
a)	Buildings (D-1 to D-5)												
1)	Less than 10 m in height												
	i) Up to 300 persons	R	R	NR	R	NR	R (see Note 4)	R	NR	NR	20 000 (5 000) (see Note 6)	NR	450 (450) (see Note 6)

Appendix-A - (Continued)

Sl. No.	Type of Building Occupancy	Type of Installation								Water Supply (liter)		Pump capacity (liter/min)	
		Fire Extinguisher	First Aid Hose Reel	Wet Riser	Down Comer	Yard Hydrant	Automatic Sprinkler System	Manually Operated Electronic Fire Alarm System (see Note 1)	Automatic Detection and Alarm System (see Note 2)	Under-ground Static Water Storage Tank Combined Capacity for Wet Riser, Yard Hydrant and Sprinklers per set of pumps	Terrace Tank over Respective Tower Terrace	Pump Near Underground Static Water Storage Tank (Fire Pump) with Minimum Pressure of 3.5kgf/cm ² at Remotest Location	At the Terrace Tank Level with Minimum Pressure of 3.5kgf/cm ²
(1)	(2)	(3)	(4)	(5)	(6)	(7)	(8)	(9)	(10)	(11)	(12)	(13)	(14)
	ii) More than 300 persons	R	R	NR	R	NR	R (see Note 4)	R	NR	NR	25000 (5000) (see Note 6)	NR	900 (450) (see Note 6)
2)	Above 10 m but not exceeding 15 m in height	R	R	R	NR	NR	R (see Note 4)	R (see Note 1)	R	100000	5000 (5000) (see Note 6)	(see Note10)	450 (450) (see Note 6)
3)	Above 15 m but not exceeding 24 m in height	R	R	R	NR	R	R	R	R	150000	10000	(see Note10)	NR
4)	Above 24 m but not exceeding 30 m in height	R	R	R	NR	R	R	R	R	200000	20000	(see Note11)	NR
b)	D-6	R	R	R	NR	R	R	R	R	200000	20000	(see Note12)	NR
c)	D-7	For details see 6.4.4											
BUSINESS BUILDINGS (E)													
1)	Less than 10 m in height	R	R	NR	R	NR	R (see Note 4)	R	NR	NR	10000 (5000) (see Note 6)	NR	450 (450) (see Note 6)
2)	Above 10 m but not exceeding 15 m in height	R	R	R	NR	NR	R (see Note 4)	R	R	50000	5000 (5000) (see Note 6)	(see Note 14)	450 (450) (see Note 6)
3)	Above 15 m and up to 24 m in height	R	R	R	NR	R	R	R	R	100000	10000	(see Note10)	NR

Appendix-A - (Continued)

Sl. No.	Type of Building Occupancy	Type of Installation								Water Supply (liter)		Pump capacity (liter/min)	
		Fire Extinguisher	First Aid Hose Reel	Wet Riser	Down Comer	Yard Hydrant	Automatic Sprinkler System	Manually Operated Electronic Fire Alarm System (see Note 1)	Automatic Detection and Alarm System (see Note 2)	Under-ground Static Water Storage Tank Combined Capacity for Wet Riser, Yard Hydrant and Sprinklers per set of pumps	Terrace Tank over Respective Tower Terrace	Pump Near Underground Static Water Storage Tank (Fire Pump) with Minimum Pressure of 3.5kgf/cm ² at Remotest Location	At the Terrace Tank Level with Minimum Pressure of 3.5kgf/cm ²
(1)	(2)	(3)	(4)	(5)	(6)	(7)	(8)	(9)	(10)	(11)	(12)	(13)	(14)
4)	Above 24 m and up to 30 m in height	R	R	R	NR	R	R	R	R	150000	20000	(see Note 11)	NR
5)	Above 30 m in height	R	R	R	NR	R	R	R	R	200000	20000	(see Note 12)	NR
INDUSTRIAL BUILDINGS (G) (see Note 17)													
a)	Low Hazard (G-1) (see Note 18)												
	i) Covered area up to 100 m ²	R	NR	NR	NR	NR	R (see Note 4)	NR	NR	NR	5000 (see Note 5)	NR	450 (see Note 5)
	ii) Covered area more than 100 m ² and up to 500 m ²	R	R	NR	R (see Note 8)	NR	R (see Note 4)	NR	NR	NR	20000 (5000) (see Note 6)	NR	450 (450) (see Note 6)
	iii) Covered area more than 500 m ² (for building height up to 15 m)	R	R	NR	R	NR	R (see Note 4)	R	NR	NR	20000 (5000) (see Note 6)	NR	450 (450) (see Note 6)
	iv) Covered area more than 500 m ² (for building height above 15 m)	R	R	R	NR	R	R (see Note 4)	R	R	75000	5000 (see Note 6)	(see Note 14)	NR

Appendix-A - (Continued)

Sl. No.	Type of Building Occupancy	Type of Installation								Water Supply (liter)		Pump capacity (liter/min)	
		Fire Extinguisher	First Aid Hose Reel	Wet Riser	Down Comer	Yard Hydrant	Automatic Sprinkler System	Manually Operated Electronic Fire Alarm System (see Note 1)	Automatic Detection and Alarm System (see Note 2)	Under-ground Static Water Storage Tank Combined Capacity for Wet Riser, Yard Hydrant and Sprinklers per set of pumps	Terrace Tank over Respective Tower Terrace	Pump Near Underground Static Water Storage Tank (Fire Pump) with Minimum Pressure of 3.5kgf/cm ² at Remotest Location	At the Terrace Tank Level with Minimum Pressure of 3.5kgf/cm ²
(1)	(2)	(3)	(4)	(5)	(6)	(7)	(8)	(9)	(10)	(11)	(12)	(13)	(14)
b)	Moderate Hazard (G-2) (see Note 18)												
	i) Covered area up to 100 m ²	R	R	NR	NR	NR	R	NR	NR	NR	10000	NR	450
	ii) Covered area more than 100 m ² and up to 500 m ²	R	R	NR	NR	NR	R	NR	NR	NR	20000	NR	900
	iii) Covered area more than 500 m ² and up to 1000 m ² (for height up to 15 m)	R	R	NR	R	NR	R	R	R	NR	50000	NR	900
	iv) Covered area more than 500 m ² and up to 1000 m ² (for height above 15 m)	R	R	R	NR	R	R	R	R	100000	10000	(see Note 14)	NR
	v) Covered area more than 1000 m ²	R	R	R	NR	R	R	R	R	150000	20000	(see Note 11)	NR
c)	High Hazard (G-3) (see Note 19)												

Appendix-A - (Continued)

Sl. No.	Type of Building Occupancy	Type of Installation								Water Supply (liter)		Pump capacity (liter/min)	
		Fire Extinguisher	First Aid Hose Reel	Wet Riser	Down Comer	Yard Hydrant	Automatic Sprinkler System	Manually Operated Electronic Fire Alarm System (see Note 1)	Automatic Detection and Alarm System (see Note 2)	Under-ground Static Water Storage Tank Combined Capacity for Wet Riser, Yard Hydrant and Sprinklers per set of pumps	Terrace Tank over Respective Tower Terrace	Pump Near Underground Static Water Storage Tank (Fire Pump) with Minimum Pressure of 3.5kgf/cm ² at Remotest Location	At the Terrace Tank Level with Minimum Pressure of 3.5kgf/cm ²
(1)	(2)	(3)	(4)	(5)	(6)	(7)	(8)	(9)	(10)	(11)	(12)	(13)	(14)
	i) Covered area up to 50 m ²	R	R	NR	NR	NR	R	NR	NR	NR	10000	NR	900
	ii) Covered area more than 50 m ² and up to 150 m ²	R	R	NR	NR	NR	R	R	R	NR	25000	NR	900
	iii) Covered area more than 150 m ² and up to 300 m ²	R	R	R	NR	NR	R	R	R	50000	10000	(see Note 14)	NR
	iv) Covered area more than 300 m ² and up to 500 m ²	R	R	R	NR	R	R	R	R	100000	20000	(see Note 10)	NR
	v) Covered area more than 500 m ²	R	R	R	NR	R	R	R	R	150000	20000	(see Note 11)	NR
STORAGE BUILDINGS(H) (see Note 20)													
1)	Below 15 m in height and covered area less than 250 m ²	R	R	NR	NR	NR	R	NR	NR	NR	25000	NR	900
2)	Below 15 m in height and covered area more than 250 m ²												
	i) Ground floor only	R	R	R	NR	R	R	R	R	50000	10000	(see Note 14)	450

Appendix-A - (Continued)

Sl. No.	Type of Building Occupancy	Type of Installation								Water Supply (liter)		Pump capacity (liter/min)	
		Fire Extinguisher	First Aid Hose Reel	Wet Riser	Down Comer	Yard Hydrant	Automatic Sprinkler System	Manually Operated Electronic Fire Alarm System (see Note 1)	Automatic Detection and Alarm System (see Note 2)	Under-ground Static Water Storage Tank Combined Capacity for Wet Riser, Yard Hydrant and Sprinklers per set of pumps	Terrace Tank over Respective Tower Terrace	Pump Near Underground Static Water Storage Tank (Fire Pump) with Minimum Pressure of 3.5kgf/cm ² at Remotest Location	At the Terrace Tank Level with Minimum Pressure of 3.5kgf/cm ²
(1)	(2)	(3)	(4)	(5)	(6)	(7)	(8)	(9)	(10)	(11)	(12)	(13)	(14)
	ii) Ground plus one floor	R	R	R	NR	R	R	R	R	75000	10000	(see Note 10)	450
	iii) More than ground plus one floor	R	R	R	NR	R	R	R	R	100000	10000	(see Note 10)	450
	iv) Multi-level Car parking (MLCP)	R	R	R	NR	R	R	R	NR	150000	10000	(see Note 11)	900
HAZARDOUS BUILDINGS (J) (see Note 20)													
1)	Up to 15 m in height												
	i) Single Storey Building	R	R	R	NR	R	R	R	R	Minimum 240 min firefighting requirements	NR	(see Note 21)	NR
	ii) More than one floor building but not exceeding 15m	R	R	R	R	R	R	R	R	Minimum 240 min firefighting requirements	50000	(see Note 21)	900
MERCANTILE BUILDINGS (F)													
a)	F-1 and F-2 (see Note 16)												
1)	Less than 15 m in height												

Appendix-A - (Continued)

Sl. No.	Type of Building Occupancy	Type of Installation								Water Supply (liter)		Pump capacity (liter/min)	
		Fire Extinguisher	First Aid Hose Reel	Wet Riser	Down Comer	Yard Hydrant	Automatic Sprinkler System	Manually Operated Electronic Fire Alarm System (see Note 1)	Automatic Detection and Alarm System (see Note 2)	Under-ground Static Water Storage Tank Combined Capacity for Wet Riser, Yard Hydrant and Sprinklers per set of pumps	Terrace Tank over Respective Tower Terrace	Pump Near Underground Static Water Storage Tank (Fire Pump) with Minimum Pressure of 3.5kgf/cm ² at Remotest Location	At the Terrace Tank Level with Minimum Pressure of 3.5kgf/cm ²
(1)	(2)	(3)	(4)	(5)	(6)	(7)	(8)	(9)	(10)	(11)	(12)	(13)	(14)
	i) Ground plus one storey, with total of all floor area not exceeding 500 m ²	R	R	NR	NR	NR	R (see Note 4)	NR	NR	NR	5000 (5000) (see Note 6)	NR	450 (450) (see Note 6)
	ii) Ground plus one storey and total of all floor area exceeding 500 m ²	R	R	NR	R	NR	R (see Note 4)	R	NR	NR	20000 (5000) (see Note 6)	NR	900 (450) (see Note 6)
	iii) More than ground plus one storey	R	R	NR	R	NR	R (see Note 4)	R	NR	NR	25000 (5000) (see Note 6)	NR	900 (450) (see Note 6)
2)	Above 15 m but not exceeding 24 m in height	R	R	R	NR	R	R	R	R	100000	10000	(see Note 10)	NR
3)	Above 24 m but not exceeding 30 m in height	R	R	R	NR	R	R	R	R	200000	20000	(see Note 11)	NR
b)	Underground shopping complex (F-3)	R	R	R	NR	R	R	R	R	150000	10000	(see Note 11)	NR

Legend

R-	Required to be provided
NR-	Not required to be provided

NOTE:

- 1) MOEFA System shall also include talk-back system and public address system for the occupancies given in the table for (d) (1) (iii) under A-5,(a)(1) (iv) and (a) (2) under C-1, and (a) (2) under D-1 to D-5, in all buildings 15 m and above in height, except for A-3 and A-4 occupancies where these shall be provided for buildings of height 24 m and above. These shall also be provided in car parking areas more than 300 m² and in multi-level car parking irrespective of their areas.
- 2) Automatic detection and alarm system is not required to be provided in car parking area. Such detection system shall however be required in other areas of car parking such as electrical rooms, cabins and other areas.
- 3) Buildings above 15 m in height are not to be permitted for occupancies A-1 and A-2.
- 4) Required to be installed in basement, if area of basement exceeds 200 m².
- 5) Required to be provided if basement area exceeds 200m².
- 6) Additional value given in parenthesis shall be added if basement area exceeds 200 m².
- 7) Required to be provided for buildings with more than two storeys (Ground + one).
- 8) Required to be provided for buildings with height above 15 m and above.
- 9) Sprinklers shall be fed water from both underground static water storage tank and terrace tank.
- 10) Provide required number of sets of pumps each consisting of one electric and one diesel pump (stand by) of capacity 2280 litre/min and one electric pump of capacity 180 litre/min (*see Fig. 1*) (*see also notes 22 and 23*).
- 11) Provide required number of sets of pumps each consisting of two electric and one diesel pump (stand by) of capacity 2280 litre/min and two electric pump of capacity 180 litre/min (*see Fig. 2*)(*see also notes 22 and 23*).
- 12) Provide required number of sets of pumps each consisting of two electric and one diesel pump(stand by) of capacity 2280 litre/min and two electric pump of capacity 180 litre/min (*see Fig. 2*) (*see also notes 22 and 23*).
- 13) Lower levels in high rise buildings 60 m or above in height are likely to experience high pressure and therefore, it is recommended to consider multi-stage, multi outlet pumps (creating pressure zones) or variable frequency drive pumps or any other equivalent arrangement.
- 14) Provide required number of sets of pumps each consisting of one electric and one diesel pump (stand by) of capacity 1620 litre/min and one electric pump of capacity 180 litre/min (*see fig. 1*) (*see also Notes 22 and 23*).
- 15) Required to be provided for buildings with more than one storey.

- 16) Buildings above 30 m in height not to be permitted for Group B, Group C, Group D and Group F occupancies.
- 17) The requirements given in this table for Group G Industrial Buildings are for small scale industry units. For other industries the requirements will have to be worked out on the basis of relevant Indian Standards and also in consultation with the local fire authorities.
- 18) Buildings above 18 m in height not to be permitted for G-1 and G-2 occupancies.
- 19) Buildings above 15 m in height not to be permitted for G-3 occupancies.
- 20) Buildings above 15 m in height not to be permitted for Group H and Group J occupancies. However, buildings above 45 m in height shall not be permitted for multi-level car parking (MLCP) Occupancy.
- 21) Pump capacity shall be based on the covered area of the building.
- 22) One set of pumps shall be provided for each 100 hydrants or part thereof, with a maximum of two sets. In case of more than one pump set installation, both pump sets shall be interconnected at their delivery headers.
- 23) Alternative to provisions of additional set of pumps, the objective can be met by providing additional diesel pump of the same capacity and doubling the water tank capacity as required for one set of pumps.
- 24) As per the requirement of local authority dry riser may be used in hilly areas, industrial areas or as required.
- 25) The buildings indicated in Col.(2) of above table shall include the following buildings:

Group A- Residential Buildings:

This shall include, among others, Apartment Houses, Dormitories, Hostels, Barracks, Hotels

Group B- Educational Buildings:

This shall include, among others, School, College, other training institutions involving assembly for instruction, education or recreation for not less than 20 students.

Group C- Institutional Buildings:

This shall include, among others Hospitals, Nursing Home, Sanatoria.

Group D - Assembly Buildings:

This shall include, among others, buildings used for Recreation, Social, Religious purpose, for example, Theatres, Motion Picture Houses, Assembly Halls, Auditoria, Exhibition Halls, Museums, Restaurants, Places of Worship, Passenger Stations, Terminals of Air public transportation services, Stadia.

Group E - Business Buildings:

This shall include, among others, Offices, Banks, Professional Establishments, Laboratories, Research Establishments, Libraries, Test Houses, Computer installations, Telephone Exchanges.

(For complete details of buildings under various Groups, *Clause 3.1.2, Page-13 of NBC 2016, Vol-1, Part-4 may be referred*)

- 26) Typical system with one electric and one diesel fire pump shall be as shown in Fig 1 and 3
- 27) Typical system with two electric and one diesel fire pump shall be as shown in Fig 2 and 4.

TERMINOLOGY

For the purpose of these Specifications, the following definitions shall apply:

1. **Air Release Valve:** A device by which the trapped air inside a riser main is expelled by water as the system is being charged.
2. **Air Vessel:** A cylindrical vessel installed in the wet-riser system at the bottom and top levels to counteract the water hammer effects.
3. **Authority concerned:** An Organization, office, or individual responsible for enforcing the requirements of a code or standard, or for approving or accepting equipment, materials, an installation, or a procedure.
4. **Automatic Fire Detection and Alarm System:** A system comprising components and sub-systems required for automatically detecting smoke, heat or fire, initiating an alarm and other actions as appropriate. This system also includes manually operated electronic fire alarm (MOEFA) system.
Note- MOEFA System (with or without automatic fire detection and alarm system) includes all or some of the components such as manual call stations (initiating an alarm for fire and other actions as required), talk-back system and public address system.
5. **Automatic Sprinkler System:** A system of water pipes fitted with sprinkler heads at suitable intervals and heights, and designed to actuate automatically, control or extinguish a fire by the discharge of water.
6. **Building, height of:** The vertical distance measured in the case of flat roofs, from the average level of the ground around and contiguous to the building or as decided by the Authority to the terrace of the last liveable floor of the building adjacent to the external wall; and in the case of pitched roofs, up to the point where the external surface of the outer wall intersects the finished surface of the sloping roof; and in the case of gables facing the road, the mid-point between the eaves level and the ridge. Where the building is located in a sloped terrain, height shall be determined from the lowest level (that is approachable by the fire service vehicles) to the terrace level. Architectural features serving no other function except that of decorations, shall be excluded for the purpose of measuring heights.
7. **Down-Comer:** An arrangement for firefighting within the building by means of down-comer pipe connected to terrace tank through terrace pump, gate valve and non-return valve and having mains not less than 100 mm internal diameter with landing valves on each floor/landing. It is also fitted with inlet connections at ground level for charging with water by pumping from fire service appliances and air release valve at roof level to release trapped air inside.
8. **Dry Riser:** An arrangement of firefighting within the building by means of vertical rising mains not less than 100 mm internal diameter with landing valves on each floor/landing which is normally dry but is capable of being charged

with water usually by pumping from fire service appliances.

9. **Fire Compartment:** A space within a building that is enclosed by fire barrier or fire resistant walls on all sides, including the top and bottom.
10. **Fire Pump:** An electric/diesel pump installed at static water tank to charge the wet riser systems.
11. **Fire Resistance Rating:** The time that a material or construction will withstand the standard fire exposure as determined by the fire test done in accordance with the standard methods of fire tests of materials/structures as per the accepted standard.
12. **Fire Service Connections:** This is a 4-way collecting breeching with blank caps (without non-return valve) fixed to a 150 mm diameter pipe which is connected to the fire tank for filling from external source:
13. **Fire Service Inlet:** A 2- or 3-way collecting head with non-return valves fitted to the down comer/wet riser main, so that in case of need, fire service can directly pressurize the system with their pump.
14. **Foot Valve:** A valve fixed in the suction strainer of the fire pump which opens only inwards to allow in-rush of water into the pump suction and fire pump when the fire pump is actuated automatically/manually.
15. **High Rise Building:** A Building 15 m or above in height (irrespective of its occupancy).
16. **Hose Reel:** Firefighting equipment, consisting of a length of tubing fitted with a shut-off nozzle and connected to a reel, with a permanent connection to a pressurized water supply.
17. **Jockey Pump:** A pump of small capacity which is set to come into operation, automatically with drop in static pressure in the system and to automatically stop when the pre-set pressure is attained.
18. **Landing valve:** An assembly comprising valve(s) and outlet(s) connection from a riser system.
19. **Priming Tank:** A small tank erected in/over the pump house above the firefighting pumps to keep the pump casing and suction of the fire pump permanently flooded.
20. **Pressure Switch:** A switch connected on delivery line of fire pump or in the body of hydro- pneumatic tank at pre-set pressure level so designed to automatically start the fire pump or jockey pump, as the case may be, when the pressure in the system falls below the pre- set level.
21. **Pump Panel:** Panel comprising starting, stopping and indicating devices of fire pumps.
22. **Stand-by Pump:** A pump of same capacity as fire pump, driven by a diesel engine or connected to any other alternate source of electric supply.
23. **Static Water Tank:** Underground or surface water tank, constructed to store water for firefighting purpose.
24. **Terrace Pump:** An electricity driven pump, located on the terrace connected to

a terrace tank with gate valve on suction side and to the internal hydrant system with non-return valve on delivery side.

25. **Terrace Tank:** A concrete/masonry/plastic steel tank constructed or erected on terrace of building for firefighting purpose.
26. **Wet-Riser:** An arrangement for firefighting within the building by means of vertical rising mains of not less than 100 mm internal nominal diameter with landing valves on each floor/landing for firefighting purposes and permanently charged with water from a pressurized supply.
27. **Wet-Riser-cum-Down Comer:** An arrangement for fire lighting within the building by means of vertical rising mains of not less than 100 mm. internal diameter with landing valves on each floor/landing connected to terrace tank for firefighting purpose, through a terrace pump, gate valve and non-return valve near the tank and to a fire pump, gate and non-return valves, over the static tank.

C.1 INTRODUCTION

This appendix cover suggestive guidelines for maintenance and operation of the Wet Riser System.

C.1.1 OBJECTIVE:-

- (i) To keep the entire system fully operational and functional at all times.
- (ii) In case full system cannot be kept functional for unavoidable reason, as much as possible, the installation shall be retained functional by isolating the defective section.

C.2 MAINTENANCE REQUIREMENT OF SYSTEM COMPONENTS

For maintaining firefighting system following points are to be taken care of:-

- C.2.1** To ensure availability of water in UG tank and terrace tank all the time and to maintain the tanks in clean condition.
- C.2.2** To ensure that the piping system is free from leakage. Any portion found to be leaking is to be isolated, rectified and connected with healthy system in shortest possible time.
- C.2.3** To ensure that all pumps are in good running condition. Any pump found to be defective is to be isolated by closing valves and attended immediately and put in to service in minimum time.
All pump glands shall be maintained in efficient working condition and the packing renewed as required to maintain the efficiency.
All working parts shall be kept clean and lightly oiled. Any necessary repairs shall be put in hand and carried out immediately.
- C.2.4** To ensure availability of power for electrical pumps, working of starters, switch gear and other electrical components.
- C.2.5** To ensure healthiness of diesel engine starting system, battery voltage, battery charger and availability of adequate diesel for engine operation.
- C.2.6** To check all landing valves of internal and external hydrants, isolating valves and replace the defective ones whenever necessary
- C.2.7** To check automatic operation of entire system by opening landing valves at different locations.
- C.2.8** To conduct fire drill at regular interval.

C.3 PERIODICAL TESTING

For achieving the objectives of Para C.1.1 and meeting the requirement of Para C.2 periodical testing and checking the system is essential. Various activities and their duration have been tabulated in Table C.1.

C.4 PROCEDURE

- C.4.1** Though the firefighting system operation is automatic, however for daily checking and attending to the system in case of operation, a trained pump operator shall be available round the clock.
- C.4.2** Operation and Maintenance instructions shall be available in the pump room and fire control room.

- C.4.3** Water for firefighting purpose is not to be used for any other purpose. However in order to avoid stagnation, the same shall be changed / cleaned regularly.
- C.4.4** Maintaining Diesel Engine is very important for the system operation since during fire, power supply is deliberately or un-deliberately switched off. Annual Maintenance Contract (AMC) of engine shall be given to the authorized service center of engine manufacturer. Adequate diesel should either be available in the pump house or nearby so that operation is not discontinued for want of diesel.
- C.4.5** Hydrant Mains / Ring Mains shall be tested once a fortnight with a pump delivering at its maximum pressure. A running test with two or more hose lines each 30m long operating shall be carried out.
- C.4.6** If any out let is found to be defective and replacement is not easily available the whole assembly should be removed and be replaced by blank off plate so that the system remains operational.
- C.4.7** Hose reels shall be subjected to regular inspection to ensure that all valve are functional, out let nozzle not choked. At least once in a year the same shall be subjected to operation to ensure that hose reel is in good condition and that the coupling joints are water tight. Flow should also be checked for the leakage of hose reel.
- C.4.8** All hydrants shall be examined systematically once a week to ensure that valves and spring catches are maintained in good condition. Spare washers shall be kept for hydrant valve seats.
- C.4.9** Cut-off valves shall be thoroughly overhauled annually to remove sludge and other foreign matter collected in the valve seating.
- C.4.10** All isolating valves shall be checked for operation. The valves in closed position be opened and closed couple of times and the valves in open position be closed and opened couple of times so that when required, the valves perform their function.
- C.4.11** All hose boxes/hose stations shall be inspected externally once every week to ensure that the equipment installed therein is intact. Further, the hose boxes/hose stations shall be cleaned internally and externally once a month.
- When the hose gets worn out at the tail end of the coupling(s), it is permissible to cut the end(s) of the hose. However should the lengths of the hose after cutting(s) fall below 90 percent of its original, the hose shall be discarded.
- A hose register shall be kept showing Information such as date purchased, date brought into use, date cut (if reduced in length), is useful. Any hose becoming inefficient through use, neglect or from any other cause, shall be discarded.
- Fire protection hose shall 'not be used for purposes other than fire protection and drill.
- Hose pipes and their couplings shall be checked to ensure there is no

leakage during their use. The female coupling cam tooth mechanism be operated and lubricated for ensuring ease of operation.

C.4.12 Power supply to the pump house is not to be discontinued for any reason. Alternative arrangement shall be made in case any feeding switch gear is under repair / replacement.

C.4.13 It has to be ensured that there are no obstructions in front of the hydrants impeding accessibility

C.5 FIRE DRILL

For making the users familiar with the system, Fire Drills shall be conducted for high rise buildings, in accordance with the fire safety plan, at least once every three months for buildings during the first two years. Thereafter, fire drills shall be conducted at least once every six months.

All occupants of the building shall participate in the fire drill. However, occupants of the building, other than building service employees are not required to leave the floor or use the exits during the drill.

A written record of such drill shall be kept on the premises for a three years period and shall be readily available for fire brigade inspection.

For other buildings, fire drill shall be carried out once in six months.

Local fire service and nodal officer-in-charge of various parts of the building shall be involved in conducting fire drill. Operation of the system shall be demonstrated so that all users are confident of the system and aware of their duties and responsibilities during fire.

For further details, Annexure D- Guidelines for fire drill and evacuation procedures for high rise buildings of *Vol-1, Part-4 of NBC 2016 may be referred.*

**TABLE C.1
PERIODICAL TESTING AND MAINTENANCE CHART**

S. No.	System Component	Activity	Duration	
1.	Water Tanks	(i) Level Check	Daily	
		(ii) Cleaning	Once in a year	
2.	Pumps	(i) Running	Daily (for min. 5 minutes)	
		(ii) Test flow	Annually	
		(iii) Lubrication	Quarterly	
		iv) Gland packing check	Weekly	
		<i>Electrically Driven Pumps:</i>		
		i) Bearing grease cup	Weekly	
3.	Engine	(i) Running	Daily (for 5 minutes)	

		(ii) Lubrication	Quarterly
		(iii) Battery Status	Weekly
		(iv) Fuel Tank check	Daily
		(v) Servicing	As per engine manufacturer's recommendations.
4.	Motor	(i) Running	Daily
		(ii) Starter contact checking	Weekly
		(iii) Insulation Resistance	Half yearly
5.	Hydrant Mains / Ring Mains	i) Testing	Fortnightly
6.	Piping	(i) Pressure	Daily
		(ii) Flushing	once in a year
7.	Hydrants	examination	Weekly
8.	Valves (Landing, Cut -off and Isolation)	(i) operation and oiling if necessary	Monthly
		(ii) Overhauling of all Cut- off valves	Annually
9.	Valves (Suction and Delivery)	(i) Examination	Half yearly
10.	Electrical Panels and Control System	(i) Operation	Monthly
		(ii) Connection and system components	Quarterly
11.	Hose boxes	i) External Inspection	Weekly
		ii) Internal and External cleaning	Monthly
12.	Hose Reel and Hose Pipes	(i) Physical check	Monthly
		(ii) Operation check	Annually
		(iii) Replacement	Depending upon physical condition.
13.	Fire Brigade Connections/ Inlet	(i) Physical check	Monthly.
		(ii) Operation check	Annually
14.	Instantaneous Coupling	(i) Physical check	Monthly.
		(ii) Lubrication	Once in Six months.
15.	Painting	(i) Out Door	Once in a year.
		(ii) In Door	Once in two years.

APPENDIX-D

MAINTENANCE OF AUTOMATIC SPRINKLER SYSTEM

- D.1 Maintenance of other firefighting installation has been described in Appendix- 'C' which hold good for sprinkler installations also. In addition following points shall be taken care.
 - D.1.1 Sprinkler shall not be re-conditioned or repaired. Used and/or defective sprinklers shall be replaced by new ones.
 - D.1.2 Sprinklers shall not be painted after installation.
 - D.1.3 Spare Sprinklers - A stock of spare sprinklers shall be kept in Fire Control Room so that prompt replacement is possible after operation/damage of a sprinkler head. A minimum of 5% of the installed capacity or 25 sprinklers of all types whichever is more shall be kept in stock.
Spanners for sprinklers and Teflon tape shall also be kept along with spare sprinklers in readiness.
 - D.1.4 As far as possible, the installation shall be maintained in operating condition by blanking off pipe work feeding the inoperative part or parts where work is taking place.
 - D.1.5 The inoperative part, if defective shall be attended to and connected with the operative system.
 - D.1.6 Action following sprinkler operation*
 - D.1.6.1 Following the operation of sprinklers, the operated head shall be replaced with new ones and water supply shall be restored.
 - D.1.6.2 The sprinklers in the vicinity of the operated sprinklers shall also be checked for damage by heat or any other cause and replaced if necessary.
 - D.1.6.3 The sprinkler pump shall not be shut off until complete extinguishment of the fire. The starting of the pump shall be automatic but the stopping of the pump after an extinguishment shall be manual.
 - D.1.7 All piping shall be examined to determine its conditions at least once a year.
 - D.1.8 All Installation Control Valves and associated equipment shall be serviced and tested annually.
 - D.1.9 Discharge test of sprinklers shall be carried out at least once in six months.
 - D.1.10 Manual testing of the system shall be carried out once in six months.
 - D.1.11 When normally opened valves are closed following system operation or test, suitable procedure shall be instituted to ensure that they are re-opened.
 - D.1.12 The entire system shall be flushed at least once in a year.
 - D.1.13 The sprinkler bulbs shall be kept free from paint or dust.

D.2 MAINTENANCE GUIDELINES

Following guidelines shall be followed for sprinkler maintenance.

- D.2.1 Maintenance and testing shall be carried out in a planned and systematic manner and records kept.
- D.2.2 Only trained personnel shall be engaged in the work. Contract with qualified agency for service, test and operation is recommended.

- D.2.3 Other firefighting installations are operated manually i.e. to operate a first aid hose reel or internal/external hydrant a person is required. As such during fire, when the system is in operation, somebody in the building is aware of it. In case of sprinkler operation, no one will come to know. For looking after sprinkler installation following personnel shall be available at all hours.
- (a) A trained pump operator shall be available in the pump room.
 - (b) Depending upon the size of installations at least two or more trained personnel shall be available in fire control room.

LIST OF RELEVANT INDIAN STANDARDS

S. No	IS No.	Title
1)	IS-8757	Glossary of terms associated with Fire safety
2)	IS-884	Specification for first-aid hose reel for firefighting
3)	IS-901	Specification for couplings, double male and double female instantaneous pattern for firefighting,
4)	IS-902	Specification (for suction hose couplings for firefighting Purposes (third revision)
5)	IS-903	Specification for fire hose delivery couplings, branch pipe, nozzles and nozzle spanner. (fourth revision)
6)	IS-904	Specification for two and three- way suction collecting heads for firefighting purposes.
7)	IS-907	Specification for suction strainers, cylindrical type for firefighting purpose. (second revision)
8)	IS-908	Specification for fire hydrant, stand post type. (second revision)
9)	IS-909	Specification for underground fire hydrant. Sluice valve type
10)	IS-636	Specification for Non percolating flexible firefighting delivery hose.
11)	IS-7637	Glossary of terms for firefighting equipment.
12)	IS-937	Specification for washers for water fittings for firefighting purposes.
13)	IS-1641	Code of practice for fire safety of buildings (general): General Principles for fire grading and classification.
14)	IS-1642	Code of practice for fire safety of buildings (General) : Details of construction. (second revision)
15)	IS-1643	Code of practice for fire safety of buildings (general) ' Exposure hazard. (first revision)
16)	IS-1644	Code of practice for fire safety of buildings (general):Exit requirements and personal hazard. (second revision)
17)	IS-1646	Code of practice for fire safety of buildings(general): Electrical installations. (third revision)
18)	IS-2871	Specification for branch pipe, universal for firefighting purposes.
19)	IS-2930	Functional requirements for hose laying tender for fire brigade use.
20)	IS-5290	Specification for landing valves.
21)	IS-8090	Specification for couplings, branch pipe, nozzle, used in hose reel tubing for firefighting.
22)	IS-8442	Specification for stand post type water and foam monitor for firefighting (first revision)
23)	IS-9972	Specification for automatic sprinkler heads. (first revision)
24)	IS-11101	Specification for extended branch pipe for fire brigade use
25)	IS -12349	Fire protection Safety sign.

26)	IS -12407	Graphic symbols for fire protection plan.
27)	IS -9668	Code of practice for provision and maintenance of water supplies and firefighting.
28)	IS -3844	Code of practice for installation and maintenance of internal fire hydrants and hose reel on premises.
29)	IS -12585	Specification for thermoplastic house (Textile Reinforced) for Water General purpose.
30)	IS -10221	Code of practice for coating and wrapping of underground mild steel pipe lines. (first revision)
31)	IS-15105	Design and installation of fixed automatic sprinkler fire extinguisher system-Code of Practice.
32)	IS -325	Three phase induction motors.
33)	IS-1822	AC Motor starter for voltage not exceeding 1000 volts.
34)	IS -3624	Pressure and vacuum gauges.
35)	IS-1520	Horizontal centrifugal pumps for clear, cold, fresh water.
36)	IS-1239	Mild steel tubes, tubulars and other wrought steel fittings.
37)	IS -3589	Specification for Steel pipes for water, and sewage
38)	IS -6392	Steel pipe flanges.
39)	IS -778	Specification for copper alloy gate, globe and check valves and water works purpose (fourth revision)
40)	IS -2592	Recommendation for methods of measurement of fluid flow by means of orifice plates and nozzles.
41)	IS -732	Code practice for electrical wiring installations.
42)	IS 900	Code of practice for installation and maintenance of induction motors.
43)	IS -1248	Direct acting electrical indicating analogue electrical Measures and their accessories general requirement instruments.
44)	IS-2516	A. C. Circuit breakers for voltages not exceeding 1000 volts.
45)	IS -4047	Heavy duty air break switches and composite units of air break switches and fuses (for voltage not exceeding 1000 volts.
46)	IS -2208	HRC cartridge fuse links up to 650 volts.
47)	IS -1554 (Part I)	PVC insulated (heavy duty) electric cables for working voltage up to and including 1100 volts.
48)	IS:1536	Specification for Centrifugally Cast (Spun) Iron pressure pipes for water, gas & sewage (first revision)
49)	IS 1537	Specification for Vertically Cast Iron pressure pipes for water, gas & sewage (first revision)
50)	IS:1538	Specification for Cast Iron Fittings for pressure pipes for water, gas & sewage (third revision)
51)	IS:780	Sluice valve for water works purposes (50 to 300 mm size)
52)	IS:13095	Butterfly valves for general purpose.
53)	IS:13039	Code of practice for provision and maintenance of External Hydrant System (first revision)

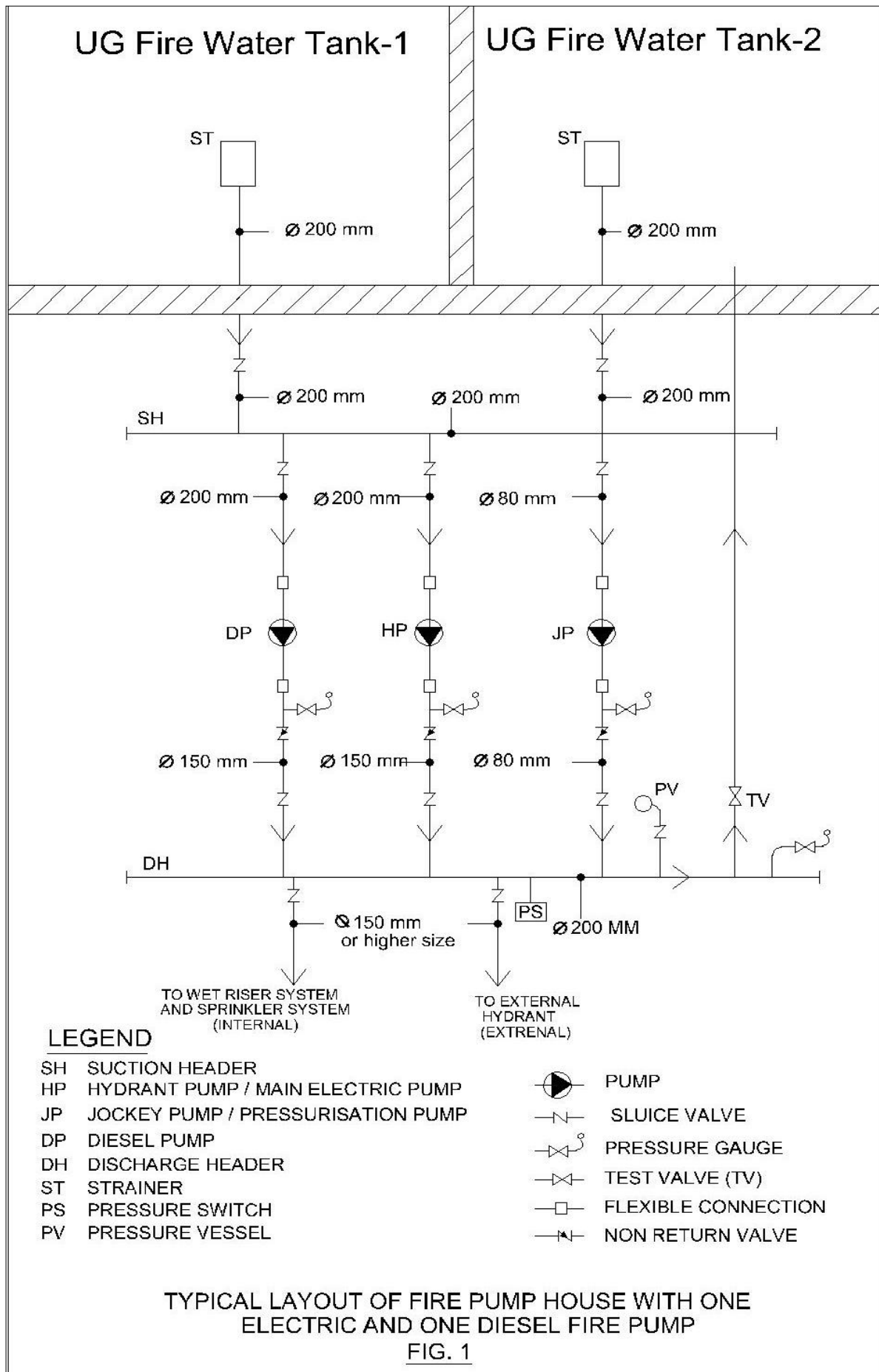

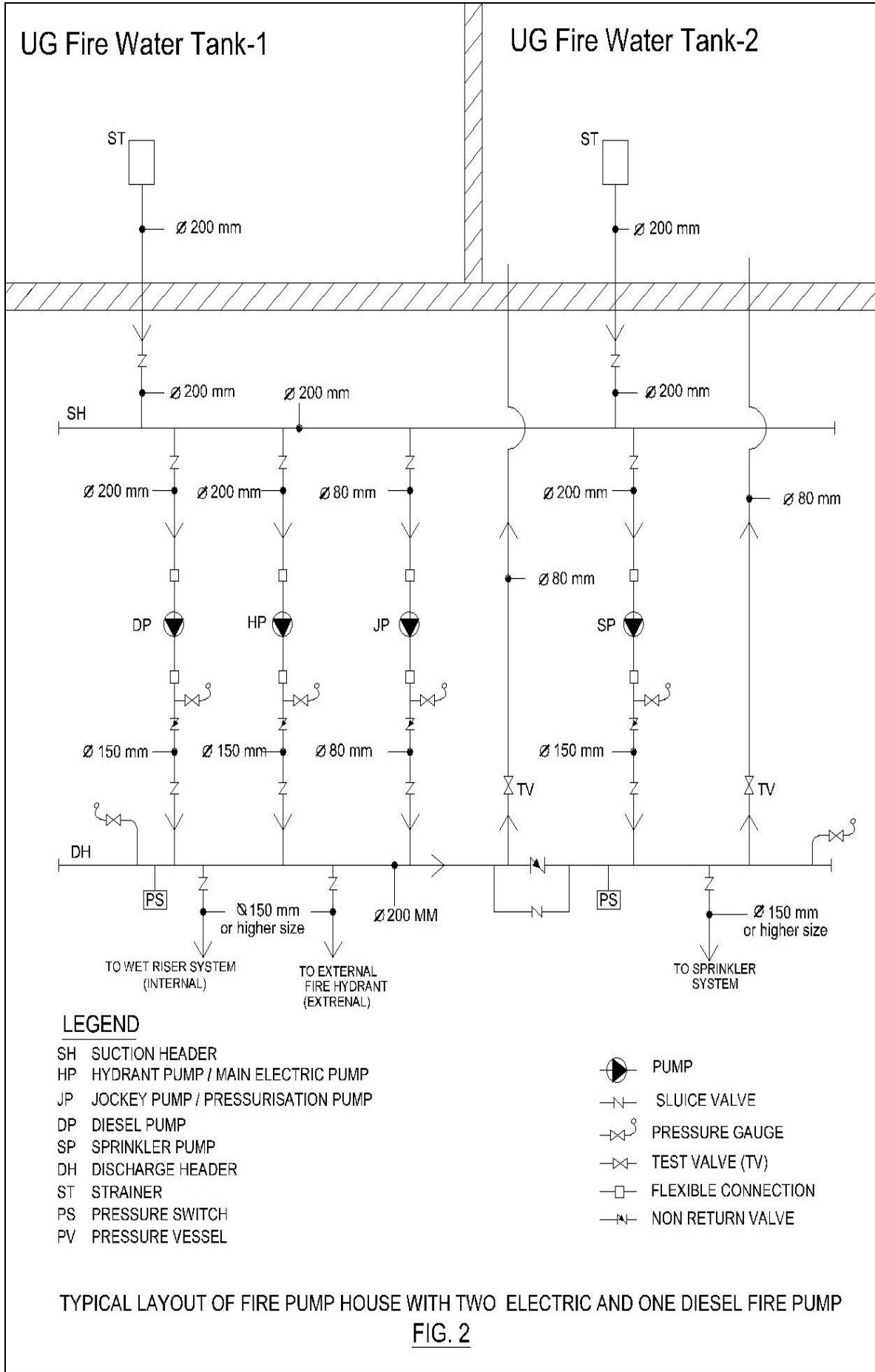

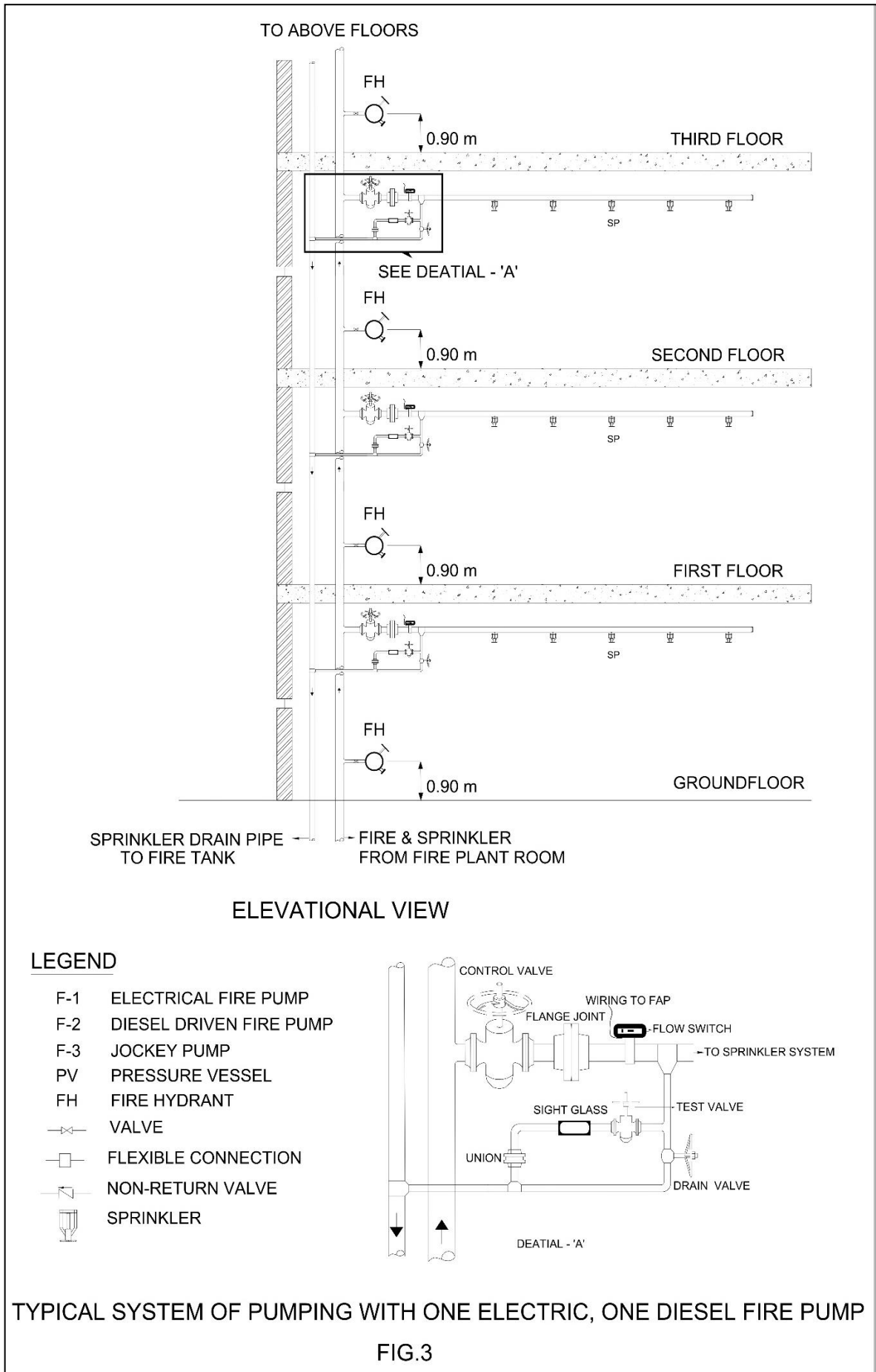

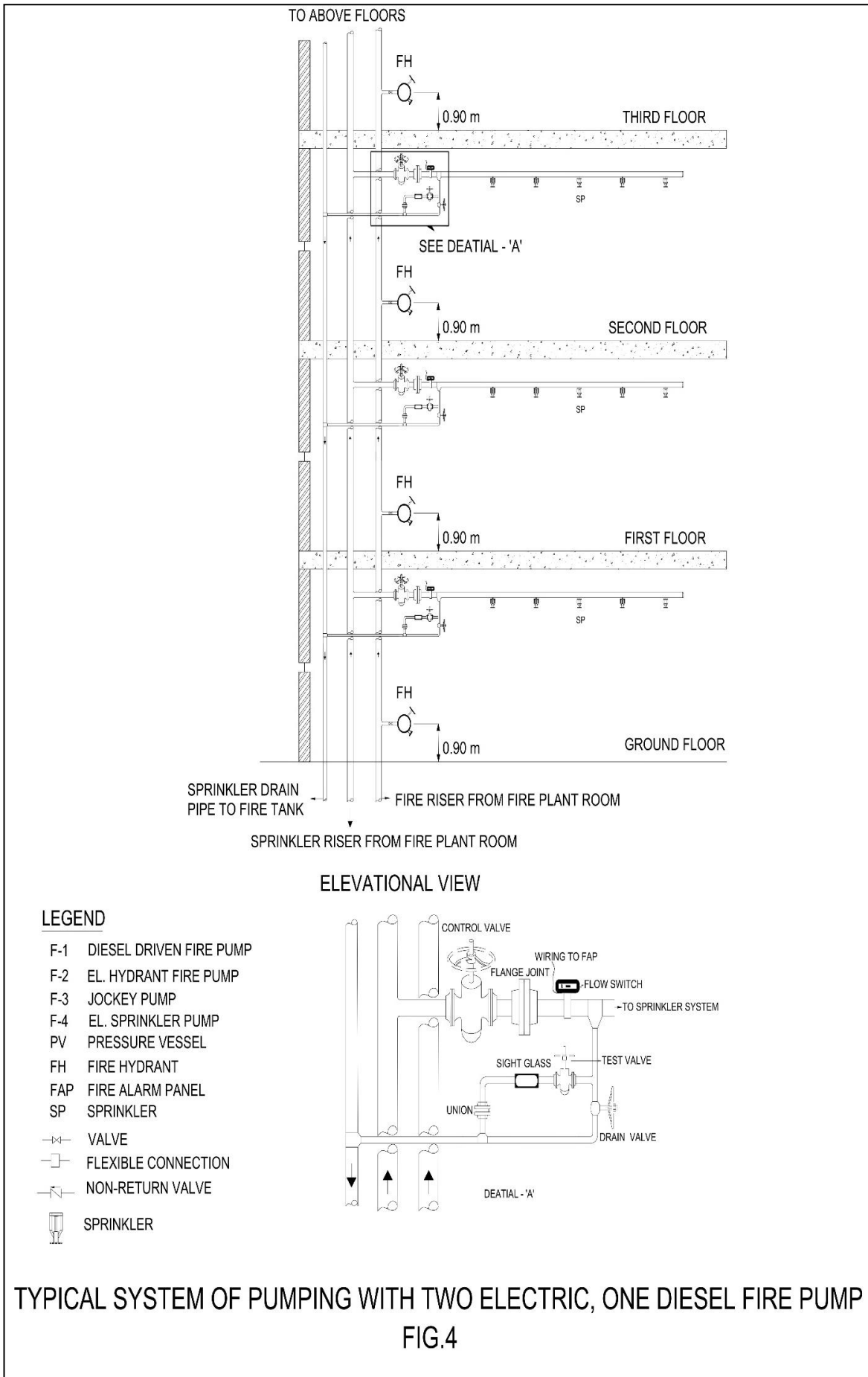

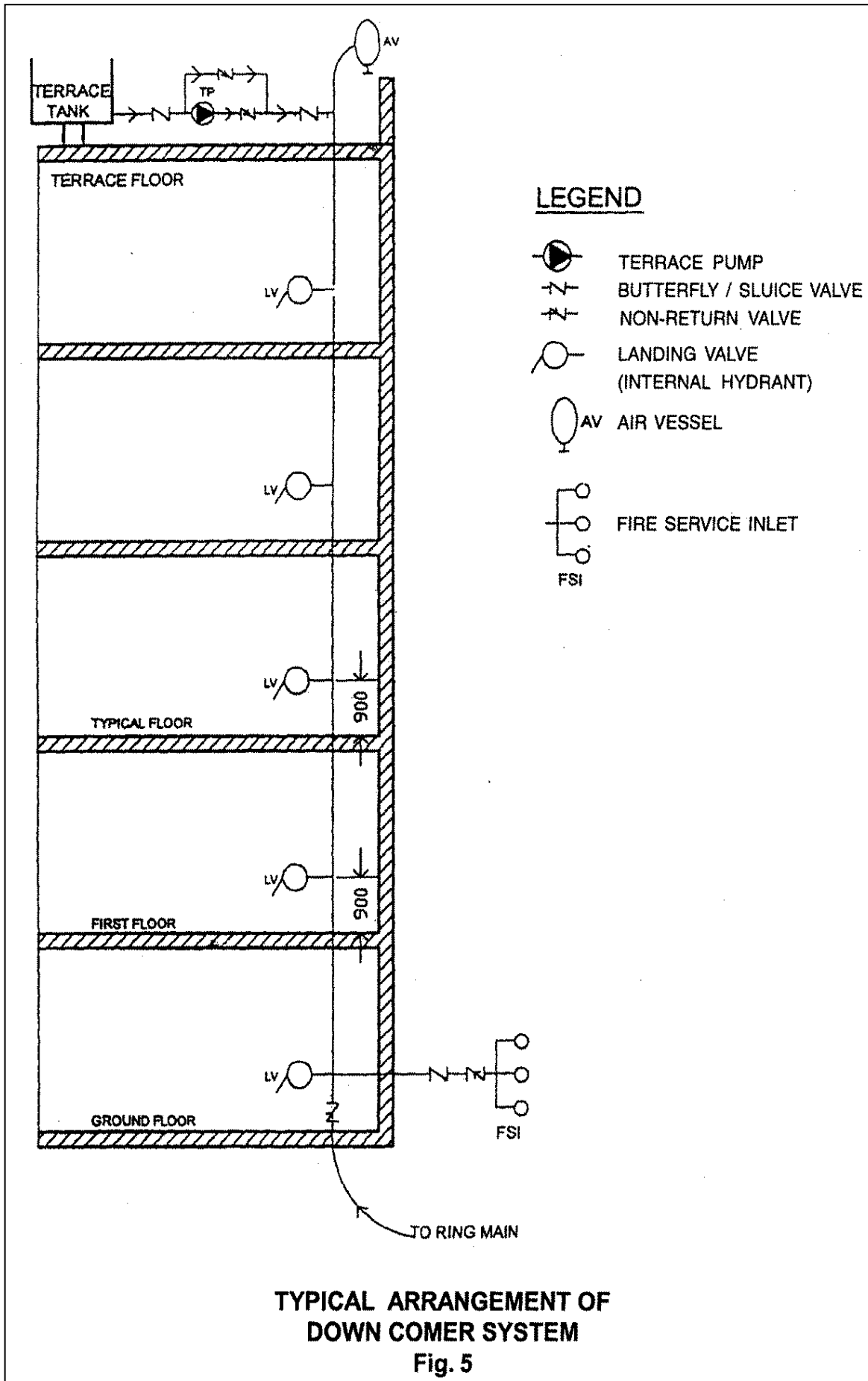













- | | | | |
|--------------------------------------|---|--|---|
| SP - SPRINKLER PUMP |  HOSE REEL |  SPRINKLER HEAD |  FIRE BRIGADE DRAW FROM TANK |
| DP - DIESEL PUMP |  SINGLE HEAD LANDING VALVE | ----- CABLE TO ANNUNCIATION PANEL |  MANUAL CALL BOX |
| JP - JOCKEY PUMP |  AIR RELEASE VALVE | --- CABLE CONDUIT FOR HOOTER & FOR MANUAL CALL BOX |  FIRE BRIGADE INLET TANK FILLING |
| HP - HYDRANT PUMP/MAIN ELECTRIC PUMP |  AIR CUSHION TANK |  HOOTER |  FLOW SWITCH |
| SH - SUCTION HEAD |  SLUICE VALVE |  NON-RETURN VALVE | |
| R - PIPE TO RISER | | | |
| Y - PIPE TO YARD HYDRANT | | | |
| S - PIPE TO SPRINKLER SYSTEM | | | |
| AV - AIR VESSEL | | | |
| ICV - INSTALLATION CONTROL VALVE | | | |

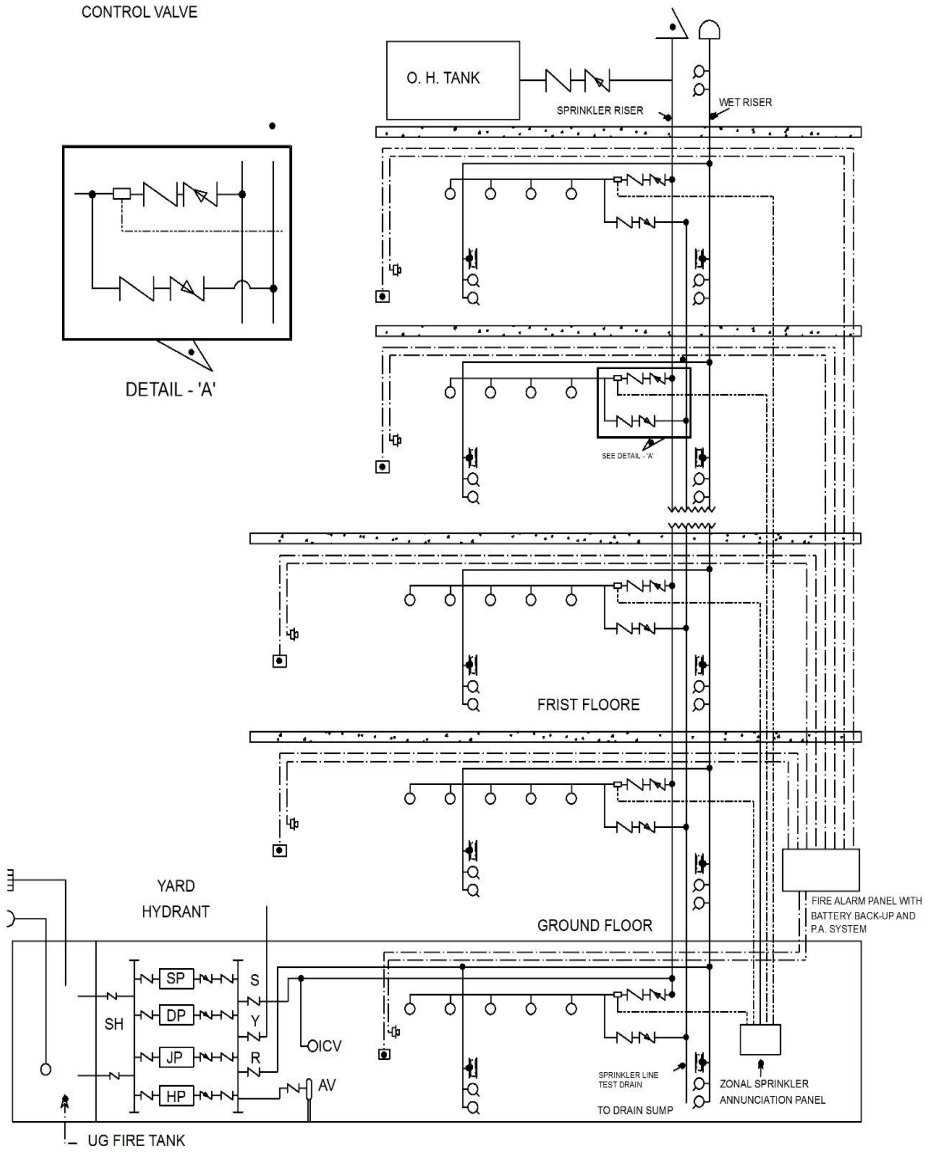

TYPICAL ARRANGEMENT OF WET RISER AND TOTAL SPRINKLER SYSTEM OF BUILDING

FIG. 6

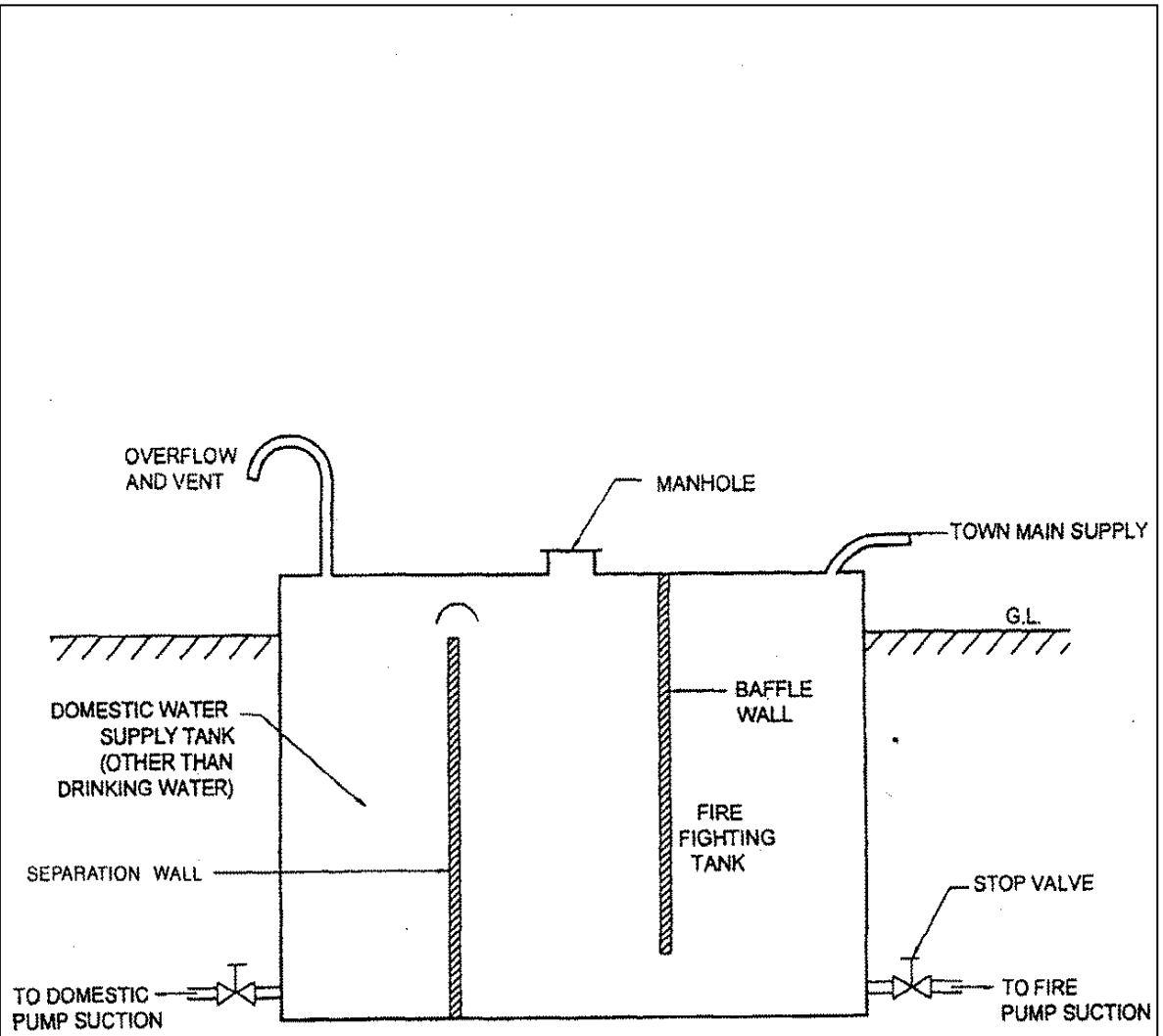

TYPICAL ARRANGEMENT FOR PROVIDING COMBINED FIRE FIGHTING AND DOMESTIC WATER STORAGE TANK
Fig. 7

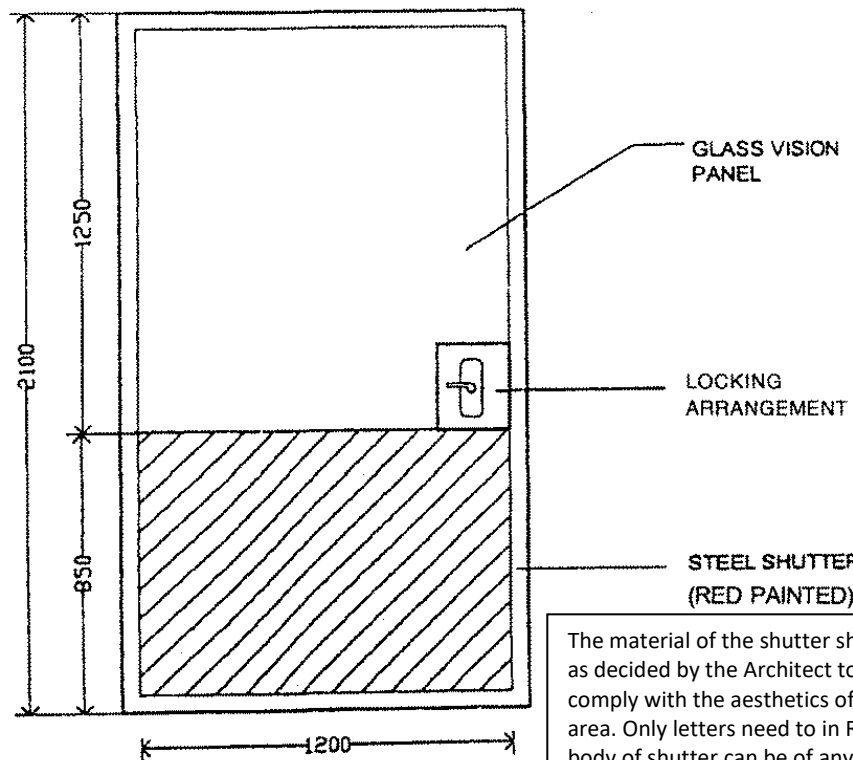

WET RISER SHAFT DOOR DETAILS

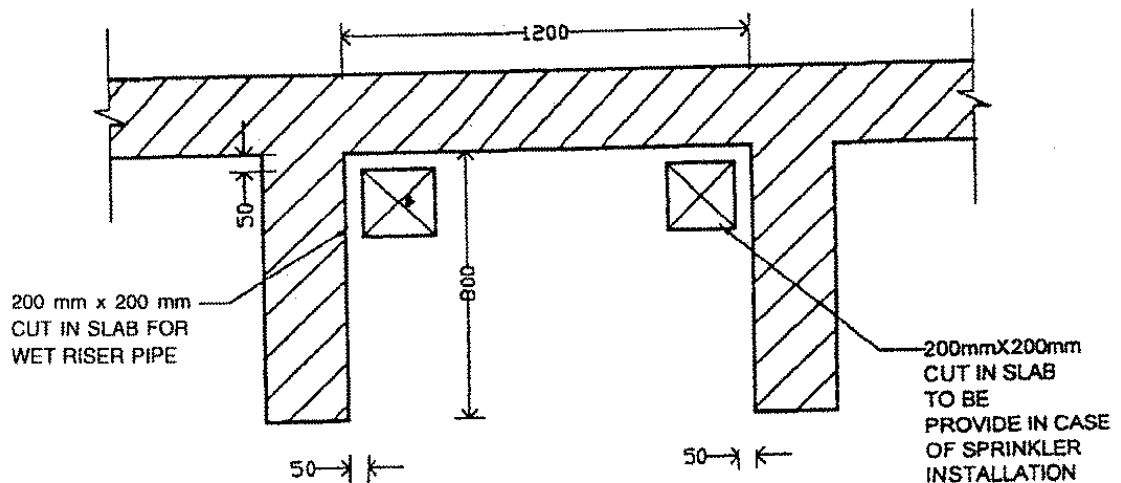

WET RISER SHAFT
Fig. 8

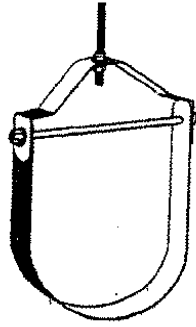

CLEVIS HANGERS

Heavy duty
clevis hangers with
pendulum movement
to adjust varying heights

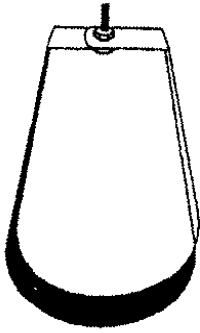

SPRINKLER HANGERS

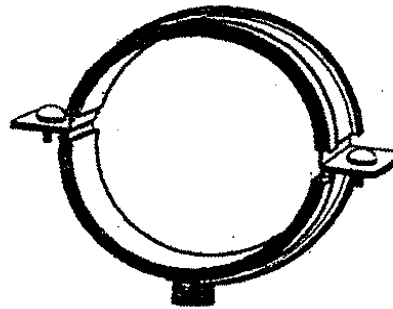

PIPE SUPPORT SPLIT CLAMP

split pipe support
clamps for vertical,
horizontal &
roof hanging
installation

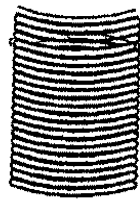

FULL THREADED RODS

in sizes
8 mm
10 mm
12 mm

TYPICAL PIPE SUPPORT

Fig. 9

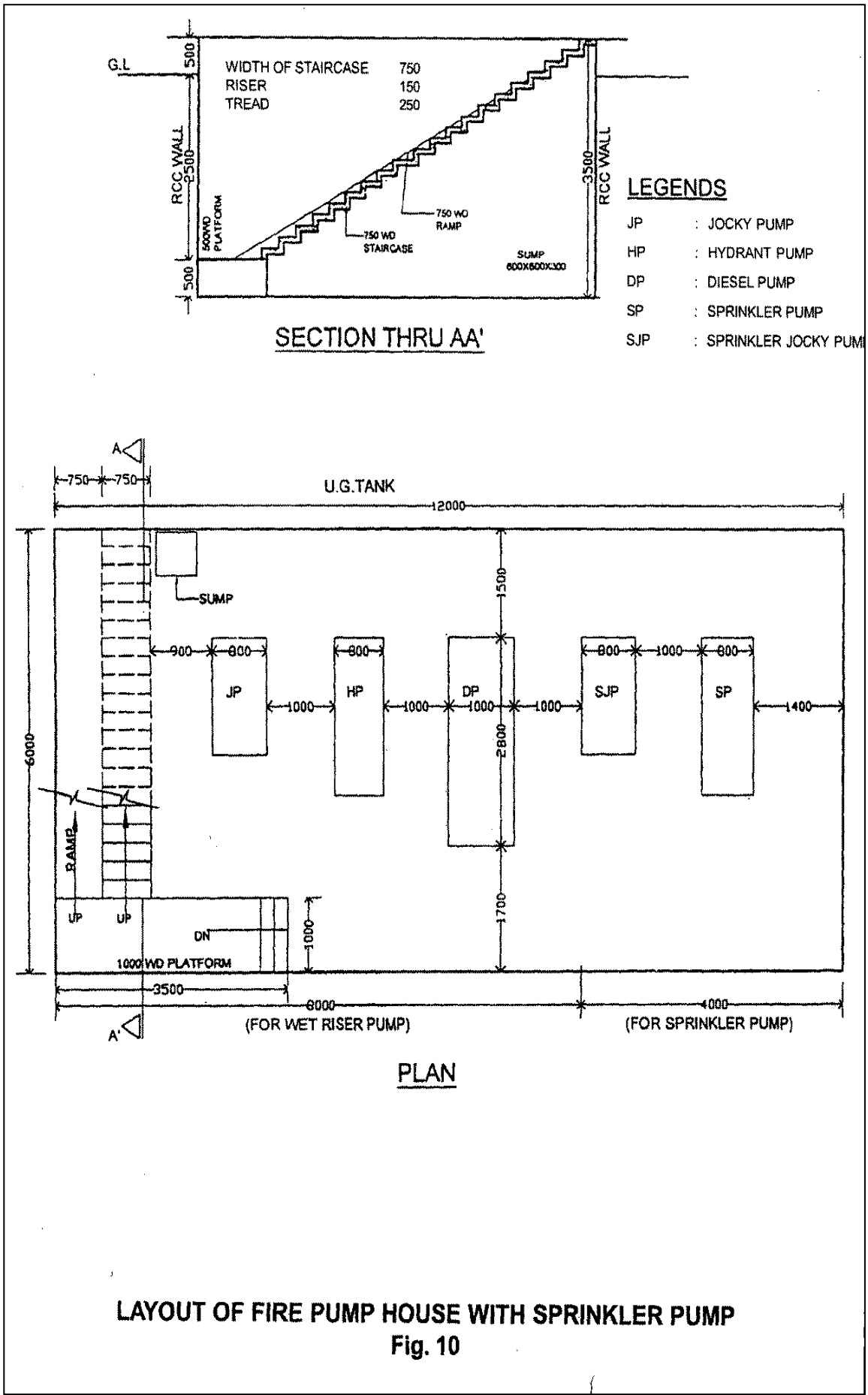

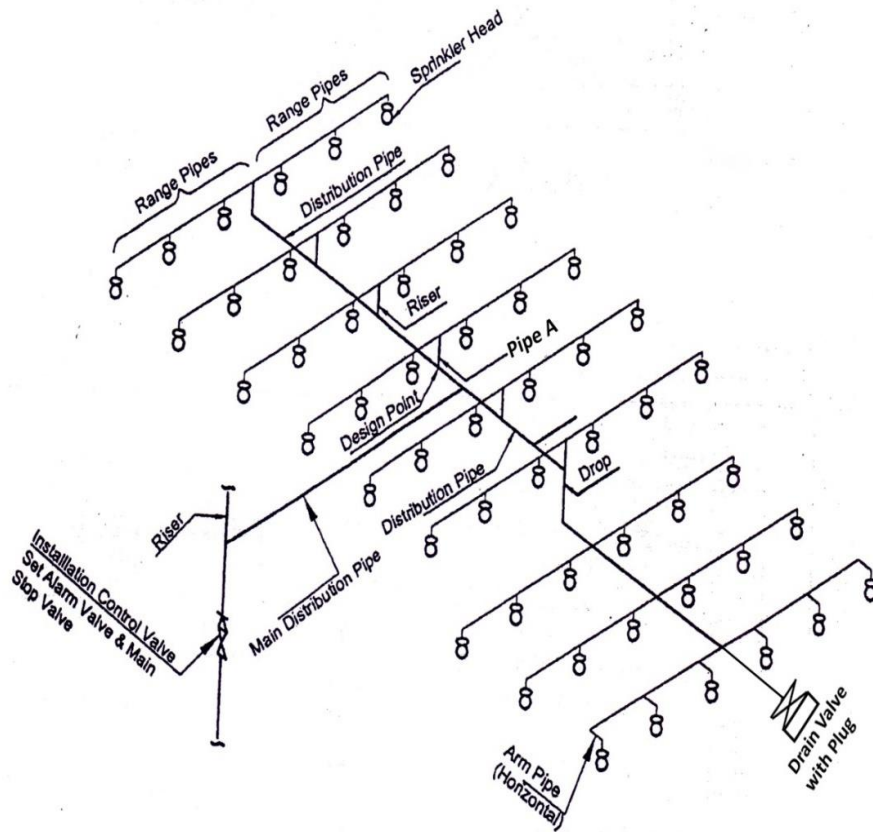

TYPICAL LAYOUT OF SPRINKLER INSTALLATION

Fig. 11

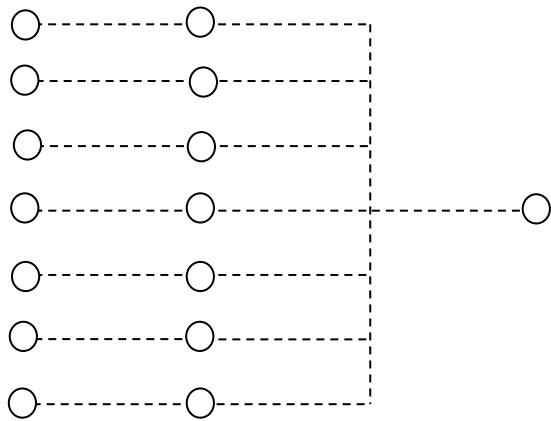

(a) Two end side with central feed

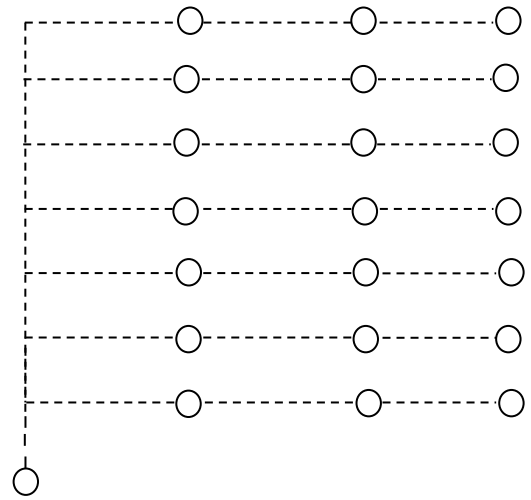

(b) Three end side with end feed

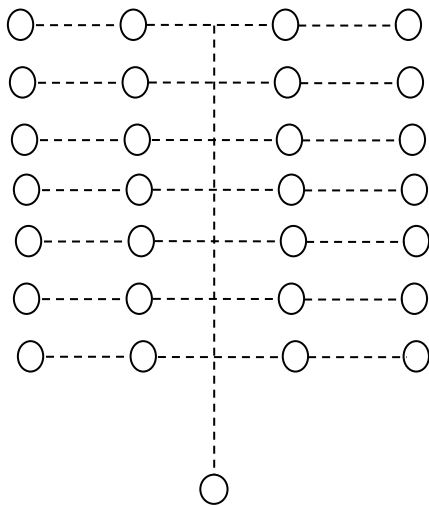

(c) Two end centre with end feed

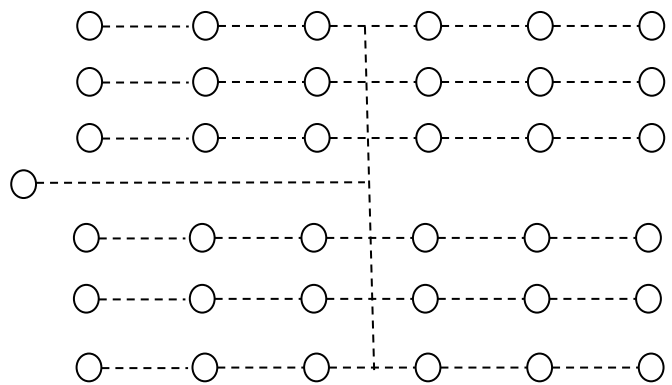

(d) Three end centre with central feed

TYPICAL LAOUT OF CONNECTION OF SPRINKLERS
Fig. 12

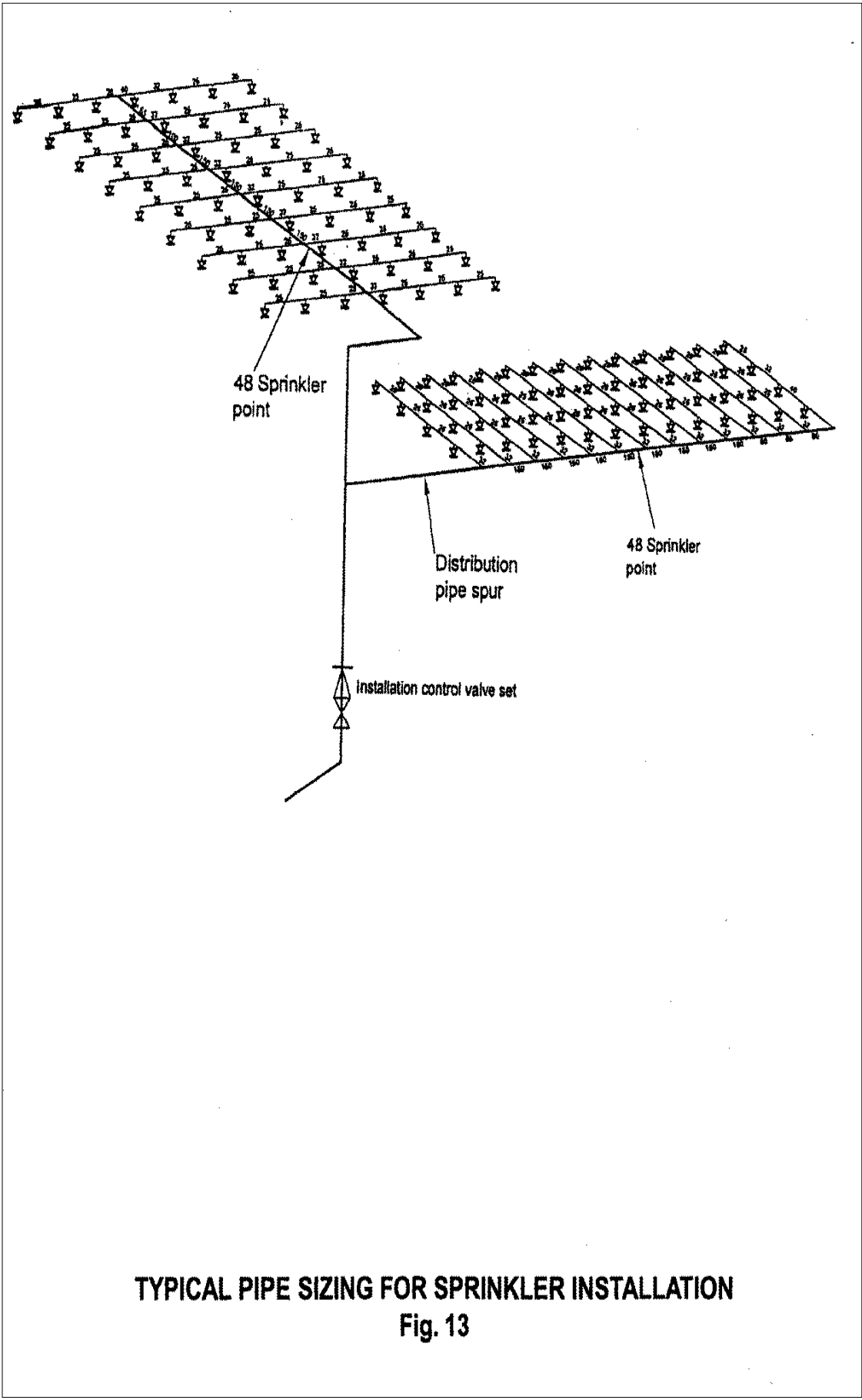

TYPICAL PIPE SIZING FOR SPRINKLER INSTALLATION
Fig. 13

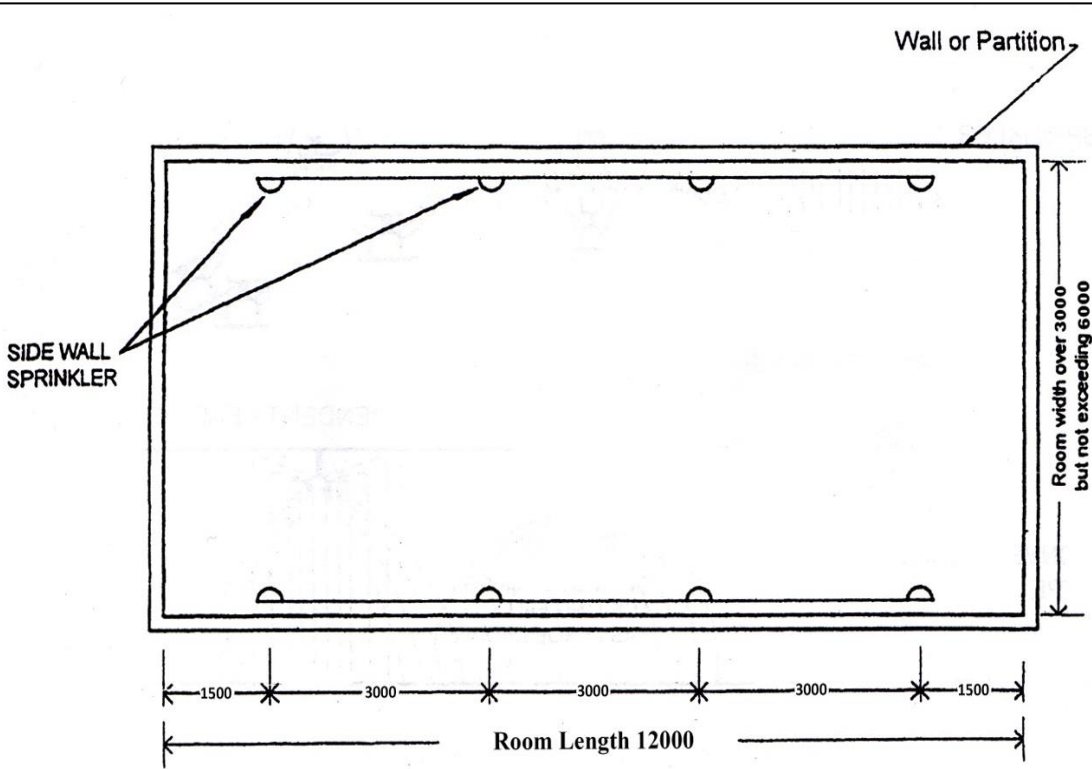

(a) Rooms over 3000 but not more than 6000 wide

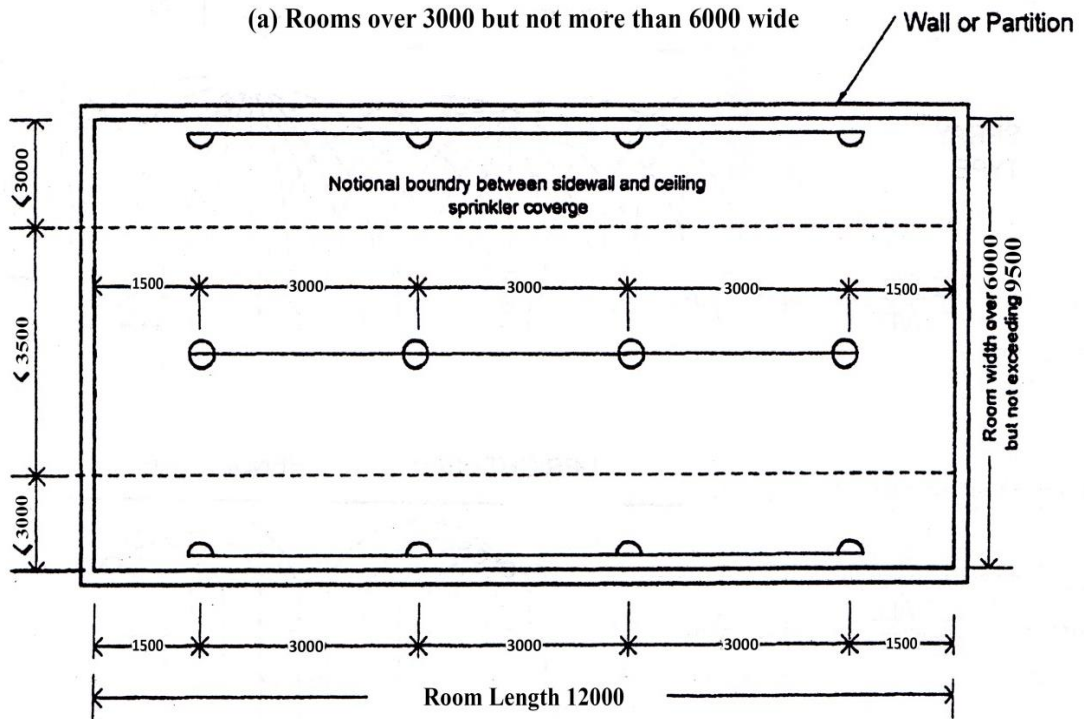

(b) Rooms more than 6000 but not more than 9500 wide
(All dimensions are shown in millimetres)

SIDEWALL SPRINKLER SPACING

Fig. 14

SPRINKLER

UPRIGHT



PENDENT



CONVENTIONAL
TYPE

UPRIGHT HEAD

PENDENT HEAD

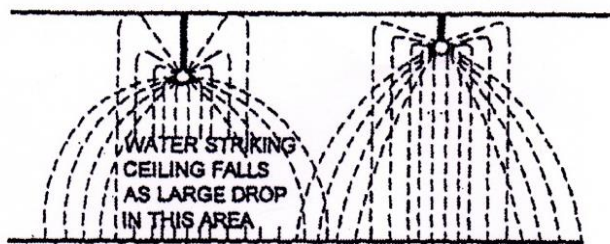

SPRAY
TYPE

UPRIGHT HEAD

PENDENT HEAD

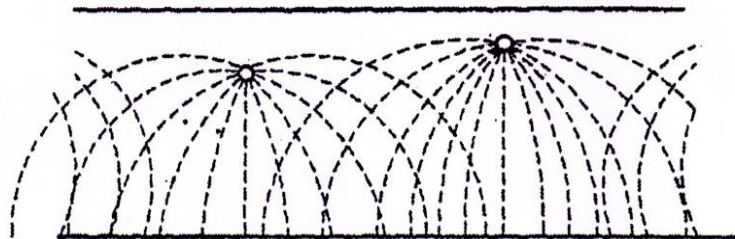

SIDEWALL
TYPE

UPRIGHT HEAD

PENDENT HEAD

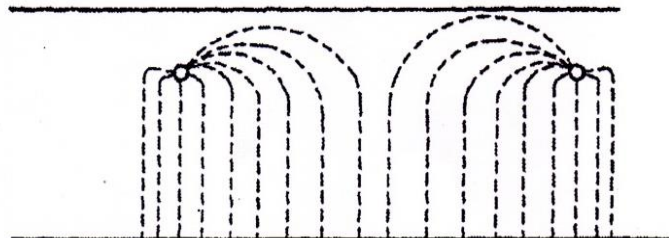

TYPE OF SPRINKLER
Fig. 15

EXTRACTS FROM NBC 2016, VOLUME-1, PART-4

1) **Clause 3.4.6.3:*****Substation/Transformers***

Areas in substation shall not be used as storage/dump areas or for other utility purposes other than those required for the functioning of the substation. The substation area should be adequately ventilated. An independent, ventilated or air conditioned MV panel room shall be provided on the ground level or first basement. This room shall be provided with access from outside (or through exit passageway accessible from outside). The MV panel room shall be provided with fire resistant walls and doors of fire resistance of not less than 120 min. If the licensees agree to provide meters on upper floors, the licensees' cables shall be segregated from consumers' cables by providing a partition in the shaft. Meter rooms on upper floors shall not open into staircase enclosures and should be ventilated directly to open air outside or in electrical room of 120 min fire resistant walls. Electrical MV main distribution panel and lift panels shall be provided with CO₂/inert gas flooding system for all panel compartments with a cylinder located beside the panel.

3.4.6.3.1 Oil filled substation

A substation or a switch-station with oil filled equipment shall be limited to be installed in utility building or in outdoor location. Such substation/utility building shall be at least 7 m away from the adjoining building(s). Substation equipment (exceeding oil capacity of 2000 liter) in utility building shall have fire rated baffle walls of 240 min rating constructed between such equipment, raised to at least 600 mm above the height of the equipment (including height of oil conservators) and exceeding 300 mm on each side of the equipment. All transformers where capacity exceeds 10 MVA shall be protected by high velocity water spray systems or nitrogen injection system.

3.4.6.3.2 Dry type substation

Transformers located inside a building shall be of dry type and all substation/switch room walls, ceiling, floor, opening including doors shall have a fire resistance rating of 120 min. Access to the substation shall be provided from the nearest fire exit/exit staircase for the purpose of electrical isolation.

3.4.6.4 Standby supply

Diesel generator set(s) shall not be installed at any floor other than ground/first basement. If the same are installed indoors, proper ventilation and exhaust shall be planned. The DG set room shall be separated by 120 min fire resistance rated walls and doors.

The oil tank for the DG sets (if not in the base of the DG) shall be provided with a dyked enclosure having a volumetric capacity of at least 10 percent more than

the volume of the oil tank. The enclosure shall be filled with sand for a height of 300 mm. For detailed information regarding fire safety requirements for hazardous petroleum products, reference may be made to The Petroleum Act, 1934 and the Rules framed thereunder.

2) **Clause 4.10.1:** A qualified fire officer with experience of not less than 3 years shall be appointed who will be available on the premises, for large educational complexes, business building with height 30 m and above, residential building with height 60 m and above, institutional building of 15 m and above, starred hotels and Group D-6 occupancy.

3) **Clause 6.5.2 Fire Protection for Business Buildings (Group-E)**

a) For Subdivision E-2 of Business Buildings (Group-E) (laboratories, outpatient clinics, libraries, test houses & research establishments), the requirement shall be provision of automatic fire detection alarm system, while for fire protection, CO₂ and/or foam-based installation to be planned based on the requirements.

b) For Subdivision E-3, E-4 and E-5 of Business Buildings (Group-E), the requirement shall be provision of automatic fire detection alarm system, while for fire protection, any or combination of clean agents, mist technologies, hypoxic air technology, etc., may be planned for appropriate/special situations/locations. Electrical panels may be provided with CO₂/inert gas flooding system based on the requirement and reliability of power for the functional requirement and performance.

4) **Classification of buildings based on occupancy**

The broad classification of various type of occupancies into different Groups as per NBC 2016, Vol-1, Part-4 is as under: -

1. Group-A Residential
2. Group-B Educational
3. Group-C Institutional
4. Group-D Assembly
5. Group-E Business
6. Group-F Mercantile
7. Group-G Industrial
8. Group-H Storage
9. Group-J Hazardous

5) **Annex E : Additional Requirements For High Rise Buildings**

E-5 ELECTRICAL SERVICES

The specific requirements for electrical installations in multi-storeyed buildings given in Part 8 'Building Services, Section 2 Electrical and Allied Installations' of the Code and Section 7 of National Electrical Code 2011 shall be followed. Wherever transformers are planned at higher floors, the HT cables shall be routed through a separate shaft having its own fire resistance rating of 120 min.

Wherever HT generators are planned centrally at ground or first basement level, redundant transformers and HT cables shall be planned for buildings above 60 m in height.

E-6 FIRE PROTECTION

For residential occupancies above 120 m in height and other occupancies above 60 m in height, the sprinklers shall be fed from the main and an alternate/standby riser with suitable isolation valves. The entire sprinkler system shall be designed in accordance with good practice [4(20)]. Where the height of the building exceeds 150 m to 175 m, fire water static storage and pumps shall be required to be provided at 160 m to 180 m and thereafter at intermediate floors at higher levels enabling efficient and functional firefighting installations. The static fire water storage tanks located at such levels shall have capacity at minimum half of the storage of underground static water storage tank prescribed in Appendix A of this specifications. Such tanks shall be supplemented with water supplies through one working and one standby pump of capacity 2 850 litre/min with two risers at alternate locations feeding to such fire water static storage tanks. The fire pump's requirement and capacity shall also be derived for occupancy type as per Appendix A of this specifications substituting the diesel pump with electrical pump. The fire pump room at such level shall have dedicated connectivity through passageway (with 120 min integrity) from the firefighting shaft. Such fire pump room shall have 120 min fire resisting wall and provided with adequate ventilation with talk-back connectivity to the main fire pump room and Fire Command Centre. For high rise buildings, seismic bracings shall be considered for firefighting installations depending on seismic vulnerability of the region and the type of occupancy.

E-7 FIRE AND LIFE SAFETY AUDIT

9.15 Fire and life safety audit shall be carried out for all buildings having a height of more than 15 m.

9.16 Such audits shall preferably be conducted by a third-party auditor having requisite experience in fire and life safety inspections.

9.17 Frequency of such audits shall be once in two years.

E-8 HELIPAD

For high rise buildings above 200 m in height, provision for helipad is recommended for specific requirements like landing of fire equipment, and support facilities or other emergencies.

- 6) For Firefighting Requirements of ATRIUM, *ANNEX F of NBC 2016 Vol-1, Part-4 may be referred to.*
- 7) For Firefighting Requirements of CAR PARKING FACILITIES, *ANNEX H of NBC 2016 Vol-1, Part-4 may be referred to.*

EXTRACTS FROM IS 13039 : 2014

Para 5.2.1:- The sub-station(s) and/or D.G. house(s)- supplying power to the fire pump(s) shall be of incombustible construction and shall be located at least 6 m away from all surrounding buildings.

Para 5.2.2 :- Electric supply feeder(s) to sub-station(s) supplying power to fire pump shall, consist of armoured cables buried underground which shall not pass under any building or permanent structure.

If the feeders are laid inside an underground cable duct/ gallery, they shall be placed in a corner of the duct/gallery and shall be isolated from other cables in the duct/gallery by means of fire bricks/sand packing/other suitable passive protection of at least 30 min fire rating (However, the same has been increased to 120 min in NBC 2016).

Under extenuating circumstances, where it is not feasible to lay the feeders underground, overhead feeders may be laid provided they do not fall within a horizontal distance of,

- a) 15 m of any process buildings/plant or tanks containing flammable liquids; or
- b) 6 m of any other building or tanks containing non-flammable liquids or of storage in open.

Para 5.2.4 :- A direct feeder without any tapping shall be laid from the sub-station to the pump house. The feeder shall consist of an armoured cable buried underground and shall not pass under any building or permanent Structure.

The cable run inside the substation from the breaker up to its point of burial or entry into cable duct/gallery shall be provided with suitable passive protection of at least 30 min fire rating. If the feeder is laid inside an Underground cable duct/gallery, it shall be placed in a corner of the duct/gallery and shall be isolated from other cable in the duct/gallery by means of fire bricks/sand package/other suitable passive protection of at least 30 min fire rating.

Under extenuating circumstances, overhead feeders may be laid provided they do not fall within a horizontal distance of,

- a) 15 m of any process buildings/plant or tanks containing flammable liquids or
- b) 6 m of any other building or tanks containing non-flammable liquids or of storage in open.

Note: In case of High Hazard 'B' occupancies, if the tender to the fire pump(s) is not buried underground two sets of feeder shall be provided which shall:

- a) conform to the above distance provisions:
- b) be run along two different routes in such a way that failure of more than one route due to a single mishap would be a remote possibility.

Para 5.2.6:- The electric supply to the pumping set(s) shall be entirely independent of all other equipment in the premises that is even when the power throughout the entire premises is switched off, the supply to the pump shall continue to be available un-interrupted. This can be achieved by taking the connection for the pump(s) from the incoming side of the main L. T. breaker. However, in cases where two or more transformers and/or sources of supply are connected to a common bus bar the connection may be taken through the bus bars.

Para 4.19.5:- Fire Escape/Fire Access Staircases: All staircases (protected Escape Routes) shall be pressurized as per 4.4.2.5 of NBC of India 2016. Adequate Smoke Venting facilities shall be provided for safe use.