

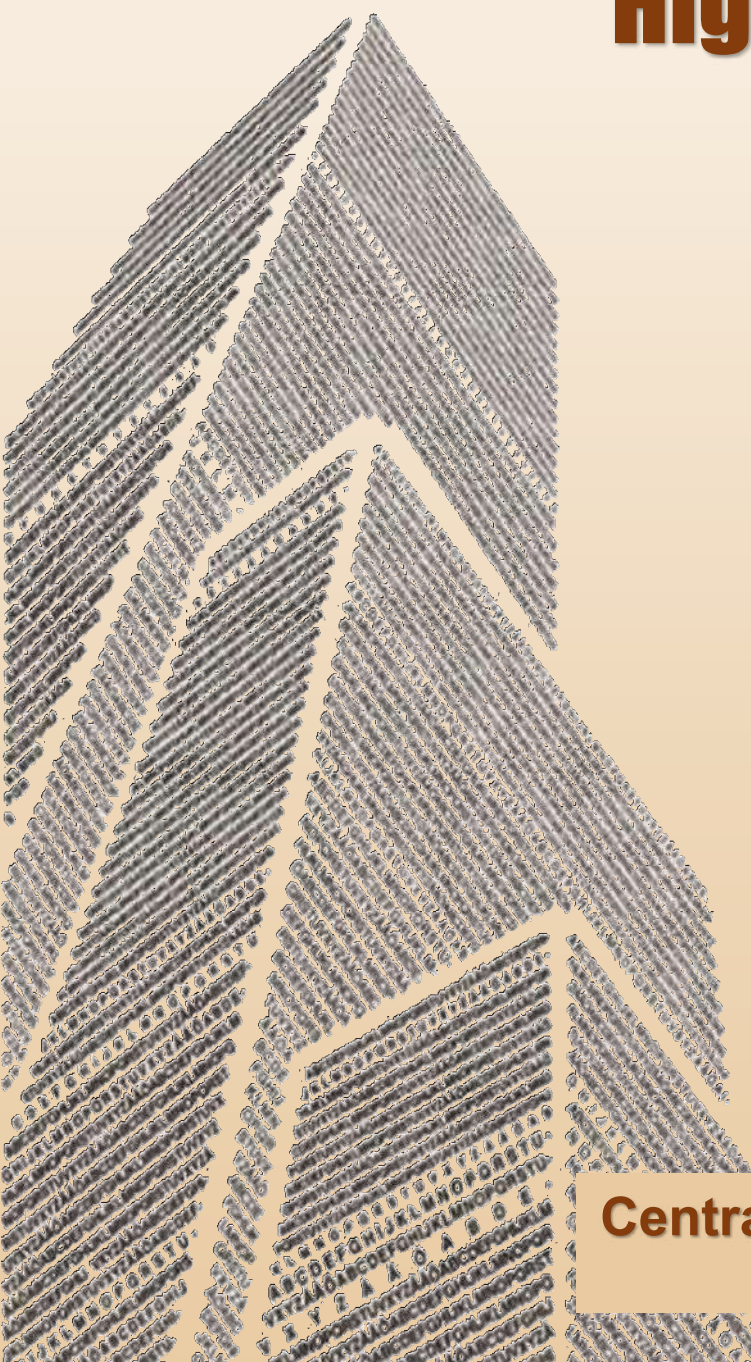

# High Rise Buildings

## December 2019



**Central Public Works Department**  
Ministry of Housing and Urban affairs



Proceedings of Seminar on

# High Rise Buildings

December 2019

(The views expressed are purely of the authors and not of the editor or their organizations)



हरदीप एस पुरी  
HARDEEP S PURI



आवासन और शहरी कार्य राज्य मंत्री (स्वतंत्र प्रभार)  
नागर विमानन राज्य मंत्री (स्वतंत्र प्रभार)  
वाणिज्य एवं उद्योग राज्य मंत्री  
भारत सरकार

Minister of State (I/C), Housing & Urban Affairs  
Minister of State (I/C), Civil Aviation  
Minister of State, Commerce & Industry  
Government of India

### Message

I note with pleasure that CPWD is organizing a National Seminar on '**High Rise Buildings**' on 13<sup>th</sup> December, 2019 in New Delhi to promote new Construction Technologies as part of the '**Construction Technology Year**' announced by the Hon'ble Prime Minister.

The construction industry is today at an inflexion point. While, on the one hand, there is increased demand due to India's development prerogatives, on the other there is a need to balance growth with sustainability. For the massive infrastructure work being carried out at present, vertical growth in the form of '**High Rise Buildings**' is an important tool to overcome many of our developmental challenges, particularly in urban areas.

CPWD is today the market leader in leveraging technological advancement in the entire construction sector. I congratulate Shri Prabhakar Singh, Director General, CPWD and his team I am sure that efforts made by CPWD towards construction of High Rise Buildings will be highlighted through this Seminar.

I congratulate the organizers once again and wish them success for the seminar.

New Delhi  
06 December 2019

  
(Hardeep S Puri)



दुर्गा शंकर मिश्र  
सचिव  
**Durga Shanker Mishra**  
Secretary



भारत सरकार  
आवासन और शहरी कार्य मंत्रालय  
निर्माण भवन, नई दिल्ली-110011  
Government of India  
Ministry of Housing and Urban Affairs  
Nirman Bhawan, New Delhi-110011



### MESSAGE

I am happy to know that Central Public Works Department is organizing one day Seminar on '**High Rise Buildings**' on **December 13, 2019** in observance of '**Construction Technology year 2019-20**' announced by the Hon'ble Prime Minister.

Indian economy has been on a steady high growth path in the past several years. Construction Sector has played a stellar role in putting India on the path of rapid economic development. There has, however, been an increasing appreciation that full potential of the construction sector in India's economic development has not been realized due to various challenges.

One of the major challenges has been efficient utilization of land, which is scarce and very expensive, especially in metro cities. 'Housing for all by 2022' Mission is now in advance stage of implementation in urban areas. In the light of limited land available, construction has to move vertical in the form of High Rise Buildings.

Construction of '**High Rise Buildings**' has its own challenges in terms of engineering design, architecture, planning of services, fire safety and maintenance etc. I hope these issues shall be deliberated threadbare during the Seminar for their solution.

I hope that day long Seminar will give an opportunity to the participants in knowledge sharing and experiential learning in the field of High Rise Buildings. I wish the Seminar a great Success !

(Durga Shanker Mishra)

New Delhi  
06 December, 2019





**PRABHAKAR SINGH**  
Director General



सत्यमेव जयते

भारत सरकार  
Government of India



केन्द्रीय लोक निर्माण विभाग

निर्माण भवन, नई दिल्ली-110011

Central Public Works Department  
Nirman Bhawan, New Delhi-110011  
Tel : 23062556/1317, Fax : 23061884  
E-mail : cpwd\_dgw@nic.in

## MESSAGE

Hon'ble Prime Minister during his address in Global Housing Technology Challenge (GHTC) Conference on March 2-3, 2019 in New Delhi, declared April 2019 - March 2020 as the '**Year of Construction Technology**' in a bid to increase the use of modern technologies in the construction sector.

Taking to clarion call of Hon'ble Prime Minister, CPWD took a pioneer role to promote use of innovative and new technologies in its works as well as to entire construction industry. CPWD, so far has approved and adopted thirty six modern technologies in its works to ensure speedy, eco-friendly, neat, tidy execution with minimal environmental pollution. CPWD has already organized two National Seminars on the 'Use of New Technologies in works' and 'Emerging Trend in Public Architecture' in observance of the ongoing Technology Year.

Moving further in this direction, as knowledge sharing of the latest developments and capacity building in the field of High Rise Buildings, CPWD is organizing a National Seminar on '**High Rise Buildings**' on 13<sup>th</sup> December, 2019 in New Delhi. This Seminar will give an opportunity to the participants to deliberate on the various aspects of planning, designing and construction of '**High Rise Buildings**'.

I am sure that the daylong seminar will give an opportunity to the participants engaged in the Construction Sector to deliberate on the subject of '**High Rise Buildings**' and come out with an action plan for the same. The learnings attained in the seminar and takeaways will be used for furthering the objectives of efficient construction of High Rise Buildings.

I congratulate Shri Anant Kumar, Additional Director General (Tech), CPWD and his team of officers for their untiring efforts in organizing this Seminar and bringing out this useful publication.

  
(Prabhakar Singh)



ANANT KUMAR



ADDITIONAL DIRECTOR GENERAL (TECH.)  
Central Public Works Department  
Nirman Bhawan, New Delhi



## PREFACE

India today is on the surge of economic growth path, where construction sector has to play most vital role towards higher goals of sustainable development, where infrastructural development in tandem with clean habitat for all, is a must.

Hon'ble Prime Minister has set the target of Housing for all by the year 2022. Also the year 2019-20 has been declared as '**Construction Technology year**' by him.

For this immense infrastructure growth with balanced sustainable development, when availability of land is scarce and at a very high premium, the answer lies in '**High Rise Buildings**'. CPWD being the spearhead of construction industry in India, understanding its responsibility in knowledge sharing on this subject is organizing this Seminar on '**High Rise Buildings**' on 13<sup>th</sup> December, 2019.

In this Seminar proceedings papers being submitted are on various topics emphasizing the technologies being followed or may be needed to be adopted in future projects of '**High Rise Buildings**'.

I am thankful to the team headed by Sh. M.K. Mallick, CE (CSQ) and Sh. Rajeev Singhal, CE cum ED, New Delhi Project Zone in bringing of this Publication.



(ANANT KUMAR)



## INDEX

S. No.	TOPIC	Page No.
1.	<b>Architectural Planning Considerations in High Rise Office Buildings</b> <i>by Ar. Usha Batra &amp; Ar. Vrushali Phadnis</i>	1
2.	<b>Some special features of Fire and Life Safety of High Rise Buildings</b> <i>by Ar. Usha Batra</i>	14
3.	<b>Multistoreyed High Rise Structures</b> <i>by Dr. K.M/ Soni</i>	27
4.	<b>Resurgence of Vertical Architecture in India</b> <i>by Ar. Dikshu C. Kukreja</i>	33
5.	<b>Seismic Control Systems</b> <i>by Er. D S Panwar</i>	45
6.	<b>Safety Challenges in High Rise Buildings and Way Forward</b> <i>by Dr. Sanjai Kumar Srivastava</i>	55
7.	<b>Arhitectural Trends in High Rise Office Buildings</b> <i>by Ar. Nitin Gupta</i>	61
8.	<b>Digital Teleportation- Ultimate Transportation in and beyond High Rise Buildings</b> <i>by Er. C K Varma</i>	65
9.	<b>Risk Assessment of Vertical Transportation System in High Rise Buildings</b> <i>by Er. C K Varma</i>	70
10.	<b>Smoke Management in High Rise Buildings</b> <i>by Er. C S Mittal</i>	75
11.	<b>Fire Safety and building services in High Rise Buildings</b> <i>by Er. Sandeep Goel</i>	86
12.	<b>Requirements for High Rise Buildings-Case Studies of IIT Bombay Projects</b> <i>by Er. P C Mathur &amp; Er Saransh Kataria</i>	92
13.	<b>Sustainability in Skyscrapers</b> <i>by Ar. Bulbul Biswas</i>	104
14.	<b>Plumbing in High Rise Buildings</b> <i>by Er. Girish Chandra Mishra</i>	118
15.	<b>Recent Advancements in Vertical Transportation System in Mega High-Rise Buildings</b> <i>by Er. Narendran R</i>	124
16.	<b>Towards Super Tall Buildings</b> <i>by Er. Vinay Gupta</i>	129
17.	<b>Airborne Disease Spread in High Rise Buildings due to reliance on Mechanical Ventilation: A Review</b> <i>by Ar. Raja Singh &amp; Prof. Dr. Anil Dewan</i>	144
18.	<b>High-Rises – Em-Towering Indian Architecture</b> <i>by Ar. Rajeev Singhal &amp; Ar. Mitu Mathur</i>	148



# ARCHITECTURAL PLANNING CONSIDERATIONS IN HIGH RISE OFFICE BUILDINGS

Ar. Usha Batra, Special Director General, CPWD

Ar. Vrushali Phadnis, Architect, CPWD

## ABSTRACT:

High rise buildings have become increasingly popular in the last few decades. High rise buildings or tall buildings are complex buildings with multiple factors affecting the design choices. Ill-considered early design choices may lead to poor and uneconomical planning and it is therefore necessary that all aspects be considered and well understood in the early conceptual design phase. The purpose of this paper is to investigate tall building design aspects from a holistic viewpoint and determine the various issues affecting the design.

The various aspects for architectural planning of high rise buildings are elaborated in the paper. The types and design of service core has been discussed in detail. Various provisions for fire in National Building Code 2016 have also been detailed out in the paper.

## INTRODUCTION:

Indian cities are witnessing immense demographic expansion due to migration from rural areas, leading to urban sprawl, housing demand, rise in cost of land etc. Industries, Trade & Commerce activities and number of Educational Centres in cities attract floating population. This has expanded cities in all directions and in turn the multiplied the complexities of urban areas. The development in urban areas can be categorised in 4 categories:

- High Rise High Density
- High Rise Low Density
- Low Rise High Density
- Low Rise Low Density

The solution to the ever increasing demand of spaces – Commercial and Residential in urban areas is in the form of Tall buildings given the availability of Modern Construction Technology.

From structural point of view it can be defined as the buildings, such that its height will be affected by lateral forces resulting from earthquakes and wind forces to the extent that such forces will play a major role in the process of design.



Due to the invention of the steel frame by William Le Baron Jenny and the elevator safety break by Eli-sha Otis, the high rise building was born. In 1885, the 10 storied Home Insurance Building became the first high rise office building in the world at Chicago, United States. Since then the buildings have grown Taller with improvement in construction and electrical technology. The LIC Building in Chennai was the First High Rise building to Completed in India in the year 1961 was 54m and 15 floors.

**PLANNING CONSIDERATIONS IN HIGH RISE OFFICE BUILDINGS:**

The current trend for constructing office buildings is to build higher and higher. High-rise buildings are more expensive to construct per square meter, they produce less usable space and their operation costs are more than conventional buildings. The space efficiency, as well as the shape and geometry of the high-rise building need to satisfy the value and cost of the development equation. Yeang (1995) stated in his book “The Skyscraper: Bioclimatically Considered” that net-to-gross floor area should not be less than 75%, while 80% to 85% is considered appropriate.

Factors affecting the design of high-rise buildings vary from place to place, such as local climate, zoning regulations, cultural conditions, technological opportunities etc. Generally the more simple and regular the floor shape is, the easier it is to respond to user requirements in terms of space planning and furnishing.

Square, circular, hexagonal, octagonal and similar plan forms are more space efficient than the rectangular plans with high aspect ratios and irregular shapes. Buildings with symmetrical plan shapes are also less susceptible to wind and seismic loads.

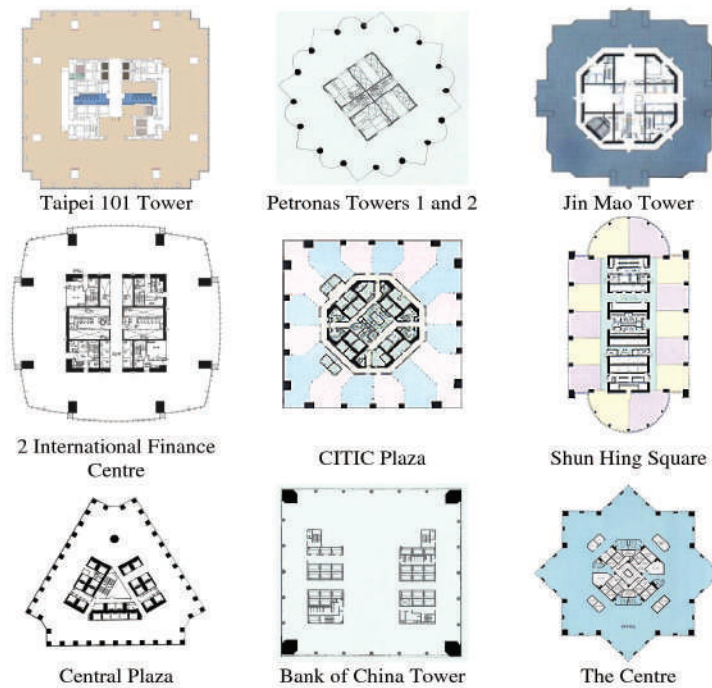

## Leasing Depth:

Leasing depth or lease span is the distance of the usable area between the exterior wall and the fixed interior element, such as the core or the multi-tenant corridor. Smaller core-to-exterior window dimensions allow the users to maintain a relationship with the outside, thus benefiting from the natural light. According to Ali and Armstrong (1995) the depth of lease span must be between 10.0 and 14.0 m for office functions, except where very large single tenant groups are to be accommodated.

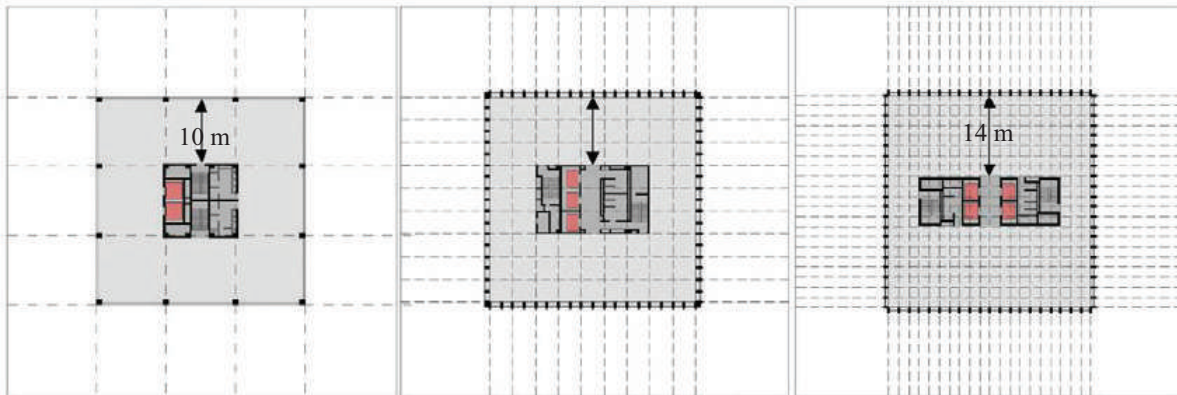

## Floor-to-floor / Floor-to-ceiling Height:

The floor-to-floor height of a building is a function of the required ceiling height, the depth of the raised floor (if used), the depth of the structural floor system and material and the depth of the space required for mechanical distribution. The floor-to-floor heights range between 3.73 m and 4.20 m with an average of 3.98 m.

**PLANNING OF SERVICE CORES IN HIGH RISE OFFICE BUILDINGS:** Service cores are an increasingly important aspect of building design, architecturally especially in High Rise buildings. In high tech building the size of service cores tends to increase thereby affecting the building's net to gross area ratio.

Simply stated, a service core is defined as those parts of a building that consist of elevators, the elevator shafts, the elevator lobby, staircases, toilets, E&M services, riser ducts. Its structure can also contribute to the structural stability of the building.

Service cores typically contain the following elements:

1. Elevator shafts.
2. Elevator lobby.
3. Staircases – both main & fire escape.
4. Toilets.
5. Ancillary rooms such as pantry.

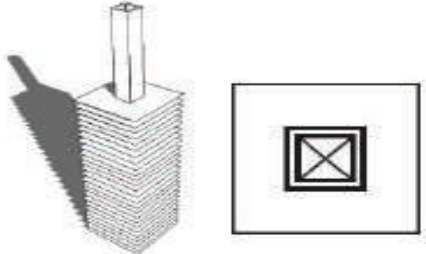
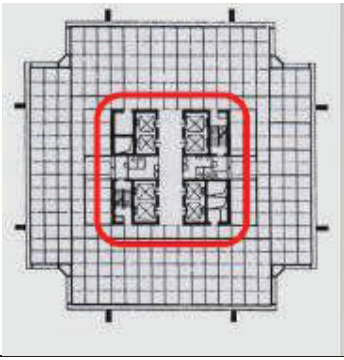
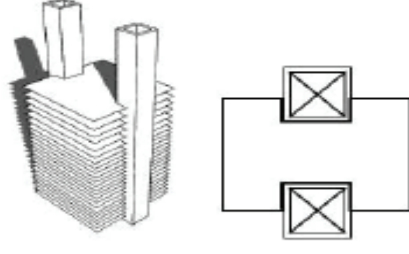
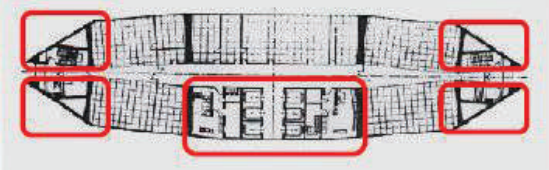
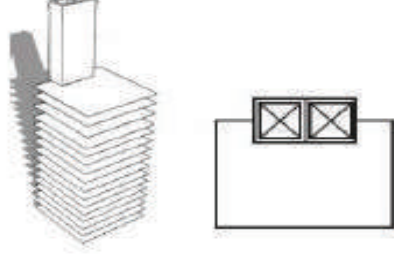
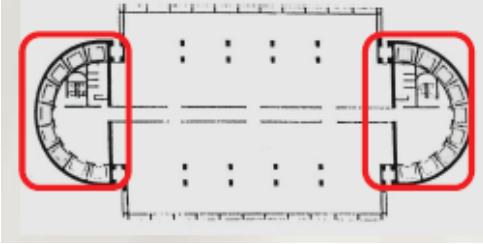
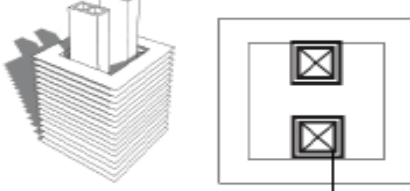
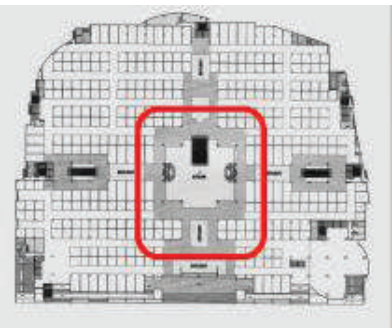

<p>CENTRAL CORE</p>	 <ul style="list-style-type: none"> <li>- Horizontal circulation is easier.</li> <li>- Requires mechanical ventilation only.</li> </ul>	
<p>SPLIT CORE</p>	 <ul style="list-style-type: none"> <li>- Individual elevators can be designated for different groups.</li> <li>- Horizontal circulation occupies more space.</li> <li>- Can have Natural Ventilation.</li> </ul>	
<p>END CORE</p>	 <ul style="list-style-type: none"> <li>- Location of core leading to inefficiency in larger floor plate.</li> <li>- Can have Natural Ventilation.</li> </ul>	
<p>ATRIUM CORE</p>	 <ul style="list-style-type: none"> <li>- Horizontal circulation is not convenient for larger floor plates.</li> <li>- Can have Natural &amp; Mechanical Ventilation.</li> </ul>	









Generally stated, glass-to-glass depths of up to 13.5m for floor plates with slab-to-slab heights of 3.6m to 4m, or a glass-to-core depth of 6m to 12m with slab height 3.8m to 4.5m, are likely to provide the widest range of space planning options.

There is also a correlation between the location of the service core and the cooling loads of the building. The cooling load is most influenced by the service core position. The split-core design with cores oriented east – west, with glazing to the north and south has a lower cooling load compared to a central-core design. The cores on the east west elevations reduce the high solar gain. The service core can be placed to serve as solar buffers, thereby enabling a passive low-energy configuration.

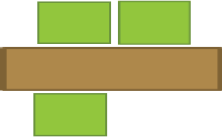
**Elevator Shaft Configuration:**

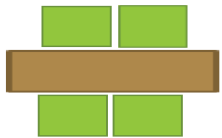
In determining the internal configuration of the service core, one of the first elements to identify is the extent to which vertical transport will be provided within the building. A large bank of elevators is the main element in service core design and all other elements are designed around it.

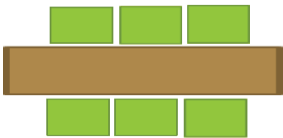
The vertical transportation of people within a high-rise building will also depend on local fire regulations. The fire department may ask for pressurization of lift lobby or compartmentation. A separate fire lift in a fire tower which can be used during fire as other lifts are in neutral position is mandatory. Following type of car groupings can be considered for various configurations of elevators.

	Preferred	Acceptable
2 car groupings		
3 car groupings		
4 car groupings		
6 car groupings		

The designer must ensure that the lobby will not be used as a common or public thoroughfare at ground floor level. In multiuse buildings care should be taken to provide separately identified lobbies for each group of elevators with clear signage. As a general guide, the width of elevator lobby should be twice the depth of elevator cars it is servicing.

### **Staircases:**

Depending on the distance between the farthest point of the floor plate and the staircase, there should be at least two escape staircase in a building so that if one of the staircases is unusable during fire the occupants will be able to use the other staircase. The staircases must be fire protected or fire compartmented in relation to the rest of the building, and act as safe spaces. The location, as required means of egress, is often one of the decisive form-givers in any major building. The escape staircases are separate from the ceremonial internal staircase if any. For high rise buildings, elevators are not considered 'legal exits' in fire emergency. Usually the fireman immediately brings all elevators down to ground floor and uses the designated fireman's elevator for fire fighting. It is the building's staircase that is the critical parts of its life safety system. It follows that both their number and location are crucial in the design.

The local byelaws go into great details about the exit requirement and the way, in which exit enclosures must be constructed, the following key points have a major impact on design:

- Use of the building – office, apartments etc.
- Total number of people in the building i.e. occupancy load determines the number of separate exits.
- The provision of fire escape exits that lead occupants to a safe area.
- Limitations on the maximum travel distance permitted to reach a fire protected exit enclosure.
- The provision of a choice of path to an exit and a choice of exit in case one is blocked.

The first three items are usually taken directly from building byelaws or National Building Code. The last two points require proper proportioning and shaping of the internal floor plate configuration in order to comply with a specific maximum 'dead end corridor' length. This can have a visible effect on the shape of floor plate and hence the overall shape of building.

### **Toilets:**

The toilets are very often located within the service core especially in high rise buildings for ease of plumbing and accessibility to the vertical risers. The extent and number of male, female, executive and disable friendly facilities are calculated, following local codes and occupancy load.

Shafts are very important from ventilation point of view as well as maintenance point of view. Minimum size of shaft, placement of pipes, access/entry to shaft for maintenance needs to be taken into account.

## E&M Service Risers:

The other essential items to be considered in the design of the service core are the vertical riser ducts for E&M services. As a rule, risers with 'wet' services should be physically separated, as should telecommunication riser ducts and those carrying electrical ducts. Floor to floor compartmentation is usually required between ducts that pass through holes in the floors of the riser cupboards, and should form part of the same compartmentation as the floor or surrounding lobby. The need for floor to floor compartmentation of services can be omitted if individual riser ducts act as fire compartments in their own right. This usually means a two-hour fire rating for ducts, including the doors. The materials for vertical E&M service risers should be non combustible with recommended fire rating.

## Refuge Area:

An area of refuge is a location in a building designed to hold occupants during a fire or other emergency, when evacuation may not be safe or possible. Occupants can wait there until rescued or relieved by fire fighters. Refuge area is required in buildings of height more than 24m. The area of each Refuge area is 4% of the area it serves. The first refuge is provided and 24m and every 7<sup>th</sup> floor above 24m.

*There are multiple external conditions and approaches that vary depending on the site & project. It is advisable to have a checklist that covers all aspects required in successful core design to meet the functional requirement of the building.*

## FIRE PROVISIONS IN NATIONAL BUILDING CODE:

NBC is a national instrument that delineates the construction norms in the country vital for the safety and development of buildings. The various important provisions in NBC related to high rise buildings & especially from fire safety point of view are listed below in brief.

1. A building 15m or above in height irrespective of occupancy is a high rise building and must obtain NOC from CFO before commencement & after completion.
2. Fire fighting Shaft / Fire Tower having 120 min fire rating comprising of protected lobby, staircase and fireman's lift, connected directly to exit at ground level is mandatory for high rise buildings as shown in Fig.
3. Refuge area is required in buildings of height more than 24m to be provided on the periphery of the floor and open to air at least on one side protected by suitable railings. Refuge areas shall be provided at/or immediately above 24m and thereafter at every 15m or so.
4. Wet Riser which is an arrangement for fire fighting within the building by means of vertical rising

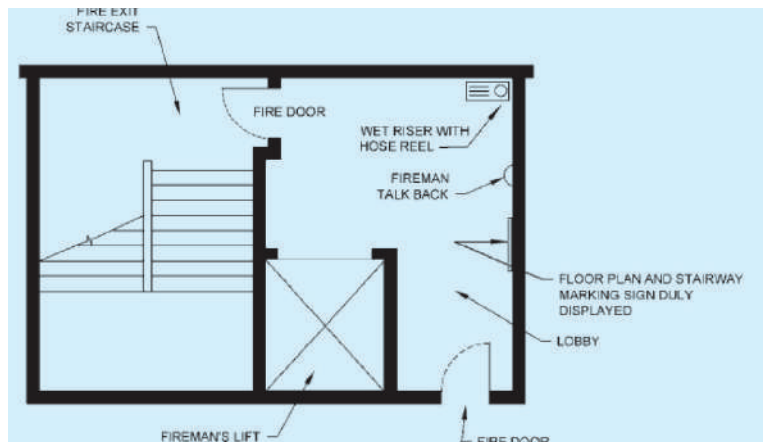

mains should not be less than 100mm nominal diameter with landing valves on each floor / landing for fire fighting purposes and permanently remain charged with water from a pressurized supply.

5. Special provisions for fire fighting that need to be provided during construction is water storage tank of 20000 lit. capacity which can be used for other construction purposes also, along with drums of 2000 lit. capacity filled with water with two buckets on each floor .
6. Emergency power supply needs to be ensured for fire and life safety systems.
7. All exit routes shall be provided with proper signage and emergency lighting.
8. Glass facade shall be in accordance with the following:
  - For fully sprinkled buildings having fire separation of 9m or more, tempered glass in a non-combustible assembly, with ability to hold glass in place, shall be provided. It shall be ensured that sprinklers are located within 600mm of the glass facade providing full coverage to the glass.
  - All gaps between floor-slabs and faced assembly shall be sealed at all levels by approved fire resistant sealant material of equal fire rating as that of floor slab to prevent fire and smoke propagation from one floor to another.
  - Openable panels shall be provided on each floor and shall be spaced not more than 10m apart. Such openings shall be operable at a height between 1.2m and 1.5m from floor, and shall be of size not less than 1000mm x 1000mm opening outwards.
9. Fire control room shall have direct access. It should have the main fire alarm panel with communication system – public address system. All controls and monitoring of fire alarm systems, pressurization systems, smoke management systems shall happen from this room. Monitoring of Integrated Building Management Systems, CCTV's or any other critical parameter in building may also be in the same room. All floor plans indicating all fire fighting details shall be maintained in this room.
10. Any basement shall have at least 2 exits.
11. The travel distance and minimum number of exits required shall be as per NBC eg. Office building will have travel distance of 30m but for fully sprinkled buildings the distance can be increased by 50% i.e 45m instead of 30m.
12. The internal staircases may be so located that it has at least one external wall. A staircase shall not be arranged around a lift shaft. The minimum width specified for each type of occupancy in NBC shall be provided.
- 13 For high rise buildings above 200m in height, provision of helipad is recommended for specific requirements like landing of fire equipment and support facilities or other emergencies.

## **SUSTAINABILITY & GREEN BUILDING CONSIDERATIONS:**

Sustainable architecture is environmentally conscious, energy saving and utilizes responsive and renewable materials and systems. The tall buildings are massive consumers of energy and therefore green building design is all the more important. The topic by itself is very exhaustive and needs detailed

investigation. Maximum advantage of daylight can be taken by shaping of plan arrangement. The orientation can be such so as to reduce the cooling / heating load. Passive design strategies like location of service core, narrower floor depth, sun shading etc. can have major impact of cooling/ heating load. Day lighting & shading are key aspects of façade design. In tall buildings the façade surfaces are very high compared to the roof area. These facades not only offer the aesthetic look and the architectural expression but can also be used advantageously to control the internal conditions for integrating photo voltaic cells in glazing and generating solar power, using double glazing to reduce cooling/ heating load etc. Innovative building technologies such as computer based Building Management Systems - BMS can help improve efficiency of services.

## **CASE STUDY:**

### **PROPOSED BUILDING FOR COAST GUARD, WORLI, MUMBAI:**

The site is located along the sea at Worli, Mumbai. The building is designed in house by CPWD, as a green iconic office tower overlooking the Arabian Sea with features derived from Sea and Ships. It is an Operational Building which will house Coast Guard Headquarter. The projected upper floors are designed in such a manner which not only compliment the form of the building but also maximizes the view of the Bandra-Worli Sea link. It is a state of art office building with all modern features.

Plot Area : 8322.20 Sq.m.

Ground Coverage : 2262.77 sqm.

Total Built Up Area: 18926.53 Sq.m.

Number of Floors: G+15 Floors.

Height of the Building: 62.8m upto terrace with helipad above.

Present Status: AE&ES awaited.

- The plot is roughly rectangular in shape with sea towards North West and road on north east.
- The site was very small in comparison with the requirements of client therefore a high rise linear built form had to be considered.





**Layout Plan**

- The Client also required some area for Parade and open activities. The major part of parking had to be
- accommodated within the building foot print. The number of cars required is 100 out of which 5 have been accommodated in automated parking in 3 levels above ground. The services like AC plant Room, Sub Station, fire room etc. along with access to automated parking has been provided at ground floor. The Clear height of Ground Floor is 8.5m for housing 3 level automatic
- parking & services. The leasing depth i.e. the distance between the exterior wall and corridor is 7 – 8.5 m average. The floor to floor height of the building is 4m. Flat slab may be provided so as to ensure minimum 2.75m below false ceiling after incorporating all services.
- Due to linear form and sea view for rooms centrally located service core is provided. This was also required as the central bay has to be free of obstructions for the automatic car parking. The efficiency of Carpet area to built up area is around 75%. Two banks of 2 lifts each has been provided one for Senior Officers & one for Staff. In addition there is a fire lift in the fire tower.
- Two staircases out of which one is in fire tower, each having 2m width has been provided. The maximum travel length to the farthest point from any staircase is within 30m as per minimum requirement of NBC. In addition automatic sprinkler has also been provided.

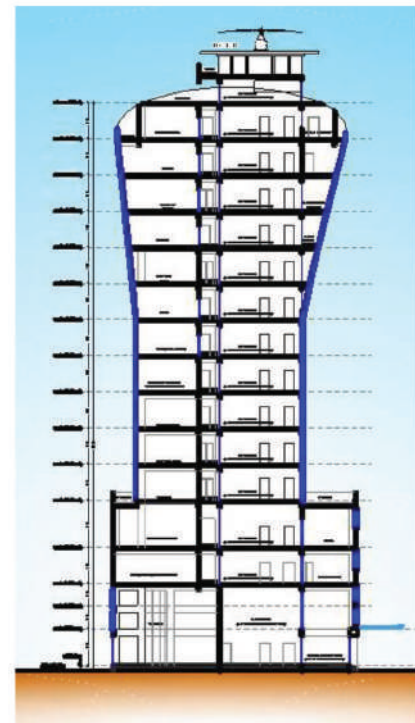

**Schematic Section**



### Floor Plan

- The toilets are located within the service core along with shaft. The minimum size of shaft as per building bye laws has been ensured. The shafts will be accessible from the toilets for maintenance.
- Services rooms & shafts provisions have been incorporated in preliminary design itself for various MEP services. All modern services like BMS, sprinkler system etc. have been provided.
- The Fire Control room has been provided on ground floor.
- Refuge areas have been provided on 6<sup>th</sup>& 11<sup>th</sup> floor of the building with 4% area it serves. The Refuge area at 6<sup>th</sup> floor basically caters to usable spaces from 6<sup>th</sup> to 10<sup>th</sup> floor. It is 4% of the usable area as per requirement of NBC.

UG Sump of 3 lakh litres capacity shall be used for domestic and fire fighting. Overhead tank 50,000 litres for domestic and 20,000 litres for fire fighting & down comer.



- Facades not only offer the aesthetic look and the buildings architectural expression but can be advantageously used to control the internal environment. Green building features like DGU will be used in glazing along with openable glass panels at regular intervals. The lower floors i.e. G+4 levels have aluminium fins along with concrete / plastered facade. Above this level glass has been used to take advantage of view.

- A provision has been made for helipad at terrace level which is basically a functional requirement of the Client for Rescue operations. The NBC 2016 recommends provision of helipad for high rise buildings above 200m in height. The helipad can also be used during emergency.

### **CONCLUSION:**

- Simple and regular shape is serene to meet the Client requirements in terms of space planning and furnishing.
- Smart core design plays a key role in increasing the efficiency of high rise building as the size of the most important element i.e. service core tends to increase affecting the efficiency which is net to gross area ratio.
- The solution to the ever increasing demand of built environment in urban areas is the Tall buildings using Modern construction technology and green materials for sustainability.
- Although facades are mainly designed for aesthetic and architectural expression but need to be advantageously used to control the internal environment to achieve sustainability.

### **REFERENCES:**

1. Service Cores – Detail in Building by Ken Yeang.
2. IACSIT International Journal of Engineering and Technology, Vol. 6 No. 1, February 2014. Paper – Study of High Rise Buildings in Indian Cities by Rupali Kavilkar & Shweta Patil.
3. National Building Code of India 2016.
4. <https://limbarup.wordpress.com/2016/09/26/high-rise-office-building-some-design-considerations/>.
5. <http://global.ctbuh.org/resources/papers/download/1308-overview-of-sustainable-design-factors-in-high-rise-buildings.pdf>

# **SOME SPECIAL FEATURES OF FIRE AND LIFE SAFETY OF HIGHRISE BUILDINGS**

**Ar. Usha Batra, SDG (PR), CPWD, Mumbai**

## **ABSTRACT**

High-rise buildings present several unique challenges not found in traditional low-rise buildings like longer egress times and distance, evacuation strategies, fire department accessibility, smoke movement and fire control.

Majority of the population are still not aware of the fire hazards or they do not even know how to react when there is a fire. Fire safety system helps us to prevent fire. It also helps us to understand the nature of fire and what steps we should take when there is a fire accident.

Part 4 of the National Building Code (NBC) of India, 2016, titled 'Fire and Life Safety' covers the requirements for fire prevention, life safety in relation to fire and fire protection of buildings. The code specifies occupancy-wise classification, constructional aspects, egress requirements and protection features that are necessary to minimize danger to life and property from fire. These requirements are taken care during construction but many times are not paid attention during alterations. Also due to sporadic requirement, neither they are maintained properly nor fire drills are regularly carried out, leading to loss of life and property to a greater extent during fire.

With more and more shift from low rise to high rise buildings, there is a need to bring greater awareness about preparedness for fire and life safety to save more lives and property.

## **INTRODUCTION**

Life safety of the occupants and fire protection of the premises are of primary concern. It is therefore necessary to educate the architects, engineers, builders and users about the need and usage of safety measures in the interests of general safety and welfare, including themselves.

Firefighting equipment being seldom used except for fighting actual fires, their maintenance is often neglected. Besides having best equipment in their perfect working order, it is equally important to have trained man power to use them, besides making the occupants conversant with the actions to be taken in case of fire as well as for speedy and orderly evacuation. Proper liaison with local fire brigade by the construction and maintenance engineers is very important and would benefit because fires which are not tackled in the initial 5 min. attain dangerous proportions soon after.

Architects and engineers must have copies of fire orders issued by fire authorities as most of them are available now online for their information and compliance which is a document containing instructions/guide lines on fire safety/fire prevention rules. It also contains details of the actions to be taken in case of fire by the occupants, their duties and responsibilities, important telephone numbers etc.

Building's evacuation plan illustrating what residents are supposed to do in the event of an emergency

should be pasted in prominent places, and the building management/maintenance engineers should hold a fire drill with occupants periodically and maintain it in working condition. NBC 2016 specifies the demarcations of fire zones, restrictions on constructions of buildings in each fire zone, classifications of buildings based on occupancy, types of building construction according to fire resistance of the structural and non-structural components and other restrictions and requirements necessary to minimise danger of life from fire, smoke, fumes or panic before the buildings can be evacuated and these provisions must be followed by government agencies, builders and public.

### **SOME INTERESTING VIEWS EXPRESSED ON NBC 2005**

When NBC 2005 was under printing, views and opinions were expressed by the authors from World Bank, IIT Kanpur and Bureau of Indian Standards. Some of the views were expressed for the sake of information only as these provisions exist in developed countries but not in India. Now more and more high rise structures are coming up in India, therefore, it was felt appropriate to make them part of this paper. Although many of the provisions are part of NBC 2005 but in a different form e.g. NBC 2005 says that the requirements of this Code should, therefore, be taken as a guide and an engineering design approach should be adopted for ensuring a fire safe design for building, whereas views expressed are - While the Code prescribes only the minimum standards of fire protection and fire safety of buildings, both in the interests of the occupants of the buildings and also in the public interests, nothing in the Part prohibits adoption of higher standards. Also, it will be necessary for all concerned to comply with all requirements of fire safety as prescribed in fire-related legislative provisions. Some interesting and worth mentioning portions are picked up for inclusion in the paper.

For ensuring the life safety of occupants from fire, the following are the requirements in general about Protected rescue paths and operations;

1. Provision of adequate No. of properly designed, unobstructed means of exit of adequate capacity which are available at all times.
2. Availability of alternate means of exit for use, if the already chosen one is inaccessible due to fire, heat, smoke and toxic gases;
3. Protection of the entire rescue path against fire, heat, smoke and toxic gases during the egress time based on occupant load, travel distance and exit capacity;
4. Adoption of compartmentation and all other adequate passive fire protection measures to ensure the safe egress/evacuation of the occupants in case of fire;
5. Provision of adequate and reliable fire alarm systems in the building to alert the occupants;
6. Provision of refuge areas where total evacuation of occupants is not contemplated;
7. (Formulation, organisation and practice of effective evacuation drill procedures.

Even if adequate exits are provided at the initial stage, often at the time of renovation/alteration, know-

ingly or unknowingly, people do not give same attention to exit requirements. In view of the above this requirement assumes great significance.

### **SOME ELEMENTS REQUIRING ATTENTION**

- Automatic Sprinkler System fails to serve their intended purpose, if they are put to non-automatic mode.
- All the passive and active fire protection requirements as per Regulations and Codes, will be of no use in terms of life safety of the occupants, in the absence of emergency lighting.
- Fire Lift can be used even by building occupants except during fire emergencies. This is a lift designed to have additional protection with controls to enable it to be used under the direct control of the fire service during fires.
- Although we provide 1hr., 2 hrs., 3 hrs. and 4 hrs. fire rating, however, in actual practice several factors affect the standard fire resistance specified e.g.
  - The amount of combustible material per unit of floor area in various types of buildings (the fire load density);
  - The height of the top floor above ground, which has a bearing of ease of escape (evacuation) and fire fighting operations.
  - Occupancy types (children/senior citizens), which again reflects the speed of evacuation;
  - The existence of basements, since basement fires may lead to accumulation of smoke and heat buildup, which may, in turn, affect the duration of fire as well as make fire fighting difficult;
  - The number of storeys in the building e.g. in a single storey, escape is direct and structural failure is unlikely.

### **Interior finishes**

Building interior finishes, particularly wall and ceiling linings, play a vital role in fire growth and eventually in fire size. It affects the fire in four ways:

- It affects the rate of heat build-up to a flash-over condition
- It contributes to flame spread over the surface,
- It adds to the intensity of fire by contributing additional fuel, and
- It produces toxic gases and smoke that adds to life hazard and property damage.

This factor is the most important since it affects occupant life safety seriously. Interior finish has been considered to be the primary cause for the heavy loss of lives in the following major fire tragedies in the world:

Date	Place	Deaths
28 Nov,1942	Coconut Grove Night Club, Boston, USA.	492
1 Nov,1970	St. Laurent Night Club, France	146
25 Dec, 1971	Hotel Fire, Seoul, Korea	165
2 Aug, 1973	Summerland Leisure Centre, Isle of Man, England	50
1 Feb, 1974	Sao Paulo, Brazil.	227
14 Nov, 1977	Flippines Hotel, Manila Philippines.	47
28 May, 1977	Beverly Hills Night Club Kentucky, USA.	165
1 Feb, 1981	Stardust Disco, Dublin	48
27 Nov, 1994	Night Club, China.	234
18 March, 1996	Ozone Disco, Manila.	162

In the above listed major fires, besides interior finish, which was the principal factor, one or more of other factors like design deficiencies, unenclosed staircases, delayed response, and lack of training also contributed to the calamities.

*Code states that finishing materials used for various surfaces and decor shall be such that it shall not generate toxic smoke/fumes.*

*Although Fire NOC is obtained on building plans but interior design / materials used in interior are not part of fire NOC. It is therefore utmost important to keep these factors in mind while designing / modifying a high rise structure.*

## **Glazing**

In case of fire door and window, if the supporting frame work to hold glass is of combustible nature, e.g. of wood, the support would be lost in case of a fire at a very early stage, and the glass would fall off defeating the very purpose for which they are provided. It means complete assembly is important, not part of assembly.

If the opening protected is more than 5m<sup>2</sup> the glass loses its fire resisting property. It will give way soon, nullifying the very purpose for which it is installed. Half an hour is the minimum fire resistance that is expected of a reasonably good building element. If this is not observed, glasses will shatter and fly off in case of fire, injuring pedestrians passing by on the surrounding streets.

*NBC 2005 states Maximum permissible area shall be 5m<sup>2</sup> for protection by wired glass or electro copper glazing. As per NBC in 2016, wherever ref has been made to fire door , it shall be as fire door assembly.*

## **External Stairs**

They serve only as an alternative means of escape in addition to the main means of escape provided inside the building. Unless they are enclosed, for tall buildings, say exceeding 8 to 10 storey, the use of these open (or partly open), external stairs may not be practicable and advisable for use for children and persons who are aged, infirm and those who are afraid of heights (those who are susceptible to vertigo)

### **Basement exits:**

Because of their situation, basement stairways are more likely to be filled with smoke and heat than stairs in ground and upper storey. Occupancies which are prohibited from being located in basements are either of high risk category, or an Assembly occupancy, making their evacuation in case of fire difficult due to smoke logging and also possible impediments to fire fighting operations. Therefore, The basic principle that basement should be served by two separate independent stairs and some activities not permitted should be strictly adhered to.

### **Static water storage tank**

Unlike in other developed countries, where well maintained hydrant water mains are available in all cities and towns, we do not have such reliable hydrant water mains even in our metropolitan cities, not to speak of towns . This being so, the only other source available for taking water for firefighting purposes are the underground static water tanks provided for the buildings (as per NBC), and the Water Tenders of various types available with the local Fire Brigades.

In a major high rise building/warehouse fire, enormous quantities of water will be required for firefighting which may last for several hours, with anything from 25-40 fire appliances working. Under these circumstances, until and unless a better alternative like a well designed city fire hydrant mains system is available, it will not be advisable to consider any reduction in the underground static water storage tank capacities, as prescribed in NBC, in the interests of public fire safety.

### **Automatic Sprinklers**

A sprinkler system is designed to check a fire in the initial stages and not to cope with a developed fire. A developed fire, beyond the scope of sprinklers, is tackled effectively by fire service intervention. In fact, it is essential that the work of fire service should supplement the automatic action of the sprinkler system to ensure that all pockets of fire are dealt with and that the water to the sprinkler system is not turned off until the fire service officer in charge gives instructions to that effect;

However when parts of buildings contain materials and processes for which water would be unsuitable as an extinguishing medium, these portions of the building can be isolated from the rest of the building by fire barriers (fire resistant walls, floors, doors, partitions etc.)

### **Additional Precautions**

Some fatal accidents have happened due to careless storage of flammable liquids in house hold occu-

pancies. Particular care has to be taken to avoid storage of low flash point flammable liquid like petrol in residential accommodation. Kitchen exhaust ducts are hazardous since they convey hot and flammable gases and vapors.

In addition they must have the required fire resistance also. The separator wall must have 4 hour fire resistance with proper fire doors and ceiling/fire stops for the openings. Either such rooms should be located at least 6m away from the main building or should be segregated from the main building by fire resistant separating walls of 4 hrs. fire resistance.

### **Exit Facilities in special cases e.g. children / patients**

This emphasizes the co-relation between occupant load and exit capacity. Educational buildings shall not be made part of mixed occupancies where other hazardous occupancy may also co-exist. In educational buildings, due care has to be taken about travel distance, number of exits, exit widths etc. Besides this, at least one staircase shall be available for evacuation, if the others become unusable due to fire. Such a provision is very important for evacuation of class rooms, particularly those used by small children, or else such children can be trapped in fire/ smoke in case of a fire emergency.

Erection of suitable fire barriers (fire resistant walls/partitions etc. of 4 hr. fire resistance) around hazardous occupancies like A/c plant, Boiler room, Transformer room etc. and the main lobby must be provided. Wherever combustible materials like wood, plywood etc. are used, they should be rendered fire resistant by fire retardant treatment.

Special facility of smoke barrier in hospital for patients confined to beds needs to be provided. A smoke barrier is a continuous protected structure or partition designed for restricting the movement of smoke. This emphasis is the need for facilities for transfer of patients from one section of a floor to another section of the same floor that is separated by a fire barrier in such a manner that patients confined to beds can be transferred with the beds, thereby getting the patients evacuated from a fire and smoke threatening area.

### **Provisions for existing buildings**

The existing buildings and structures should be inspected for fire and life safety requirements and latest provisions of the Code must be made applicable to them where ever required and feasible, specifically where any one of the following conditions exist:

- Change of use or occupancy of the building structure;
- Renovations/modifications, reconstruction or additions have been made;
- The building is found lacking in basic requirements of fire and life safety measures;
- The building/structure is considered unsafe and a threat to life, health and welfare of the occupants and (or) members of the public.

## **SOME OTHER PROBLEMS REQUIRING ATTENTION**

### **Compartmentation**

It is seldom attempted in modern buildings due to several operational as well as aesthetic considerations on the part of builders, users etc. However, this is a very important requirement from fire safety point of view, for effective confinement and control of fire and preventing the fire spreading to adjacent areas.

### **Damage caused by water**

Many a time, damage caused by water used in fire fighting has proved costlier than the fire damage itself, possibly because of the nature of the materials involved. It is therefore important that they have proper drainage arrangements in all the areas of the building. Similarly, it is equally important to have non combustible drain pipes for obvious reasons.

### **Refuse chutes**

Chutes which are used for collection and disposal of the waste from the various floors constitute a potential source of fire due to accumulation of combustible waste. Their location in staircase and a/c shafts can pose grave hazards due to chimney effect of fire. Provision of fire resistant doors at every floor level helps prevention of fire spread from floor to floor. Fires are thereby contained to floor of origin.

### **Generator supply for essential emergency services**

On detection of fire, the first normal reaction is to switch off the main electric supply, to prevent fire spread by possible short circuit etc. It is however important to keep all emergency services going which are essential for evacuation and fire fighting operation. Therefore, to have a standby generator supply which comes on automatically is a prime requirement to maintain all essential emergency services.

### **Fire fighting shafts:**

For fire fighting operations in high rise buildings, it will be almost impossible for fire fighters to carry their equipments to the upper floors of a tall building without the use of lift, which is much easier and quicker than carrying them up through stairs. In a major fire in a high rise building, fire fighting operations will involve large number of fire appliances and manpower, besides being prolonged. Under such circumstances, good fire ground communication facilities between the fire scene and Control Room are essential for ensuring operational efficiency. Buildings more than 18m in height, or with a basement of more than 10m below grade, should be provided with a fire fighting shaft. This is a protected shaft having facilities like fire fighting lifts, fire fighting stairs and fire fighting lobbies. These fire fighting shafts are designed to facilitate access of fire fighting personnel into high rise and other special hazard buildings. This facility enables the fire fighting personnel to reach the fire and conduct fire fighting operations without delay and in an efficient manner. It must be ensured that the lifts are properly maintained so that they remain available for safe operation at all times.

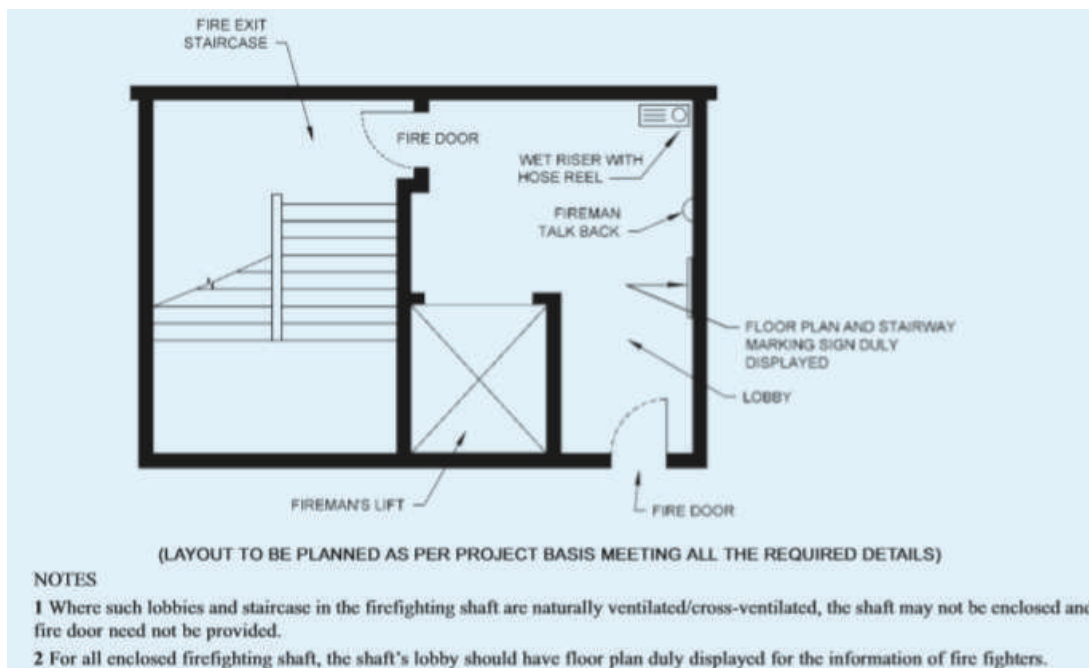

### Lift Evacuation Strategy- Modern Trends

Building Codes throughout the world had been advocating the traditional evacuation by stairs policy in fire affected buildings, especially, for high rise buildings. Years of experience have brought to focus certain facts arising from the use of staircases for evacuation in high rise buildings. Even normally healthy persons are liable to feel fatigued after about 5min. of going down stairs. Such fatigue can lead to the person getting dizzy, or slipping on the stairs, etc.

Research has found that it takes about 12 to 14 mins. to get down to the ground level using stairs from the 42nd floor of a high rise building, provided the travel is performed without a break. From buildings over 100 storeys in height, evacuees may need about 5 to 6 rest stops while coming down from the topmost floor to the ground level. Hence, including the time spent for the rest stops, it may take approx. about 40 to 45 min. for any one to reach the ground level from the top storey, which prolonged duration is not acceptable from any point of view.

*As per code, In general, buildings 15m in height or above shall be provided with fire lifts. Each fire lift shall be equipped with suitable inter communication equipment for communicating with the control room on the ground floor of the building. The speed of the fire lift shall be such that it can reach the top floor from ground level within one minute.*

*Based on experience and research, extra provisions must be made as high rise buildings once constructed shall last for at least 100 years.*

After the 11 Sept. 2001, WTC incident, many felt that had adequate Emergency Escape Lifts(EELs) were available at WTC, perhaps many more lives could have been saved. Past experience combined with research studies conducted during the last two decades, has led to the development of a new concept of Emergency Elevator Evacuation System in the developed countries.

The elevator lobby for Emergency Evacuation Lifts(EELs) should have a capacity of not less than 50% of the occupant load of the area served by the lobby. The lobby spaces should also include 1 or 2 wheel chair space of 76cm x 122cm(30 in x 48 in) for each 50 persons of the total occupant load served by that lobby. The EELs should be provided with fire fighters emergency operation devices also.

The new concept is becoming increasingly popular in many advanced countries. Incidentally, this new method has been incorporated in the design of the present-day tallest building in the world, ie., Petronas Twin Towers in Kuala Lumpur, Malaysia.

Some of the main features of the emergency evacuation lift strategy incorporated in this super high rise building are:

- The twin towers have 29 double deck elevators, (each having a capacity of 22 persons) out of which certain double deck lifts are designed as fire lifts;
- The sky lobbies on levels 41 & 42 will serve as refuge floors and staging area for egress from the upper levels(up to 80 storey)
- The shuttle lifts(Double Decker lifts) provide express service between sky lobbies and ground levels;
- Pressurization of sky lobbies;
- All lifts will be available for use in a phased evacuation mode in an emergency. Fire lifts are provided with emergency power supplies also.

#### **Corridors and Passageways:**

- As per international practice, if a corridor provides access to alternate escape routes, to avoid the risk of smoke spread, every corridor more than 12m long, which connects two or more storey exits, should be subdivided by self closing fire door(s) and any associated screens e.g. recent provisions made in Burj Khalifa.

#### **TERRACE USED AS REFUGE AREA FOR EVACUATION /HELIPAD**

For high rise buildings above 60 m in height, provision for helipad should be made. Requirement of helipad is important for very tall buildings because conventional evacuation of occupants through staircases becomes impractical and at times results in fatigue to the aged and children.

There had been several cases internationally of major high rise building fires when many persons had collected on the roofs of the burning buildings because of non availability of staircases for escape due to smoke accumulation in the escape route. In many such cases they were rescued from the roof tops using helicopter sorties. Some of the outstanding cases are mentioned below:

Date	Place	Remarks
24 Feb, 1972	Andraus Bldg. Sao Paulo, Brazil (24 storeys)	Roof used as heliport. A shuttle service of 11 helicopters used to rescue over 350 persons from the roof.
01 Feb, 1974	Joelma Bldg. Sao Paulo, Brazil (21 storeys)	72 persons rescued by helicopters
25 Dec, 1971	Hotel, Seoul, S. Korea	6 rescued by helicopters.
21 Mar, 1981	Office Bldg., Santiago, Chile (35 storeys)	Helicopters rescued several
6 June, 1983	Office Bldg., Gopala Towers, Delhi (14 storeys)	6 rescued by helicopters
31 Dec, 1986	Dupont Plaza Hotel Puerto Rico (20 storeys)	Helicopters rescued several
4 May, 1988	Office Bldg., California, US (62 storeys)	8 rescued by helicopters
20 Nov, 1996	Office Bldg., Hong Kong (16 storeys)	Several were rescued by helicopters.

*As per NBC 2005 For high rise buildings above 60 m in height, provision for helipad should be made. and NBC 2016 For high rise buildings above 200m in height provision of helipad is recommended for emergency evacuation.*

### **SOME OUTSTANDING PROBLEMS EXPERIENCED BY THE FIRE PERSONNELS**

Some of the outstanding problems which had been experienced during fire fighting operations in high rise buildings are;

- External fire fighting and rescue difficulty
- Evacuation prolonged/difficult
- Rescue and fire fighting mainly from within the building
- Being fully air conditioned, traps heat and smoke during fires, danger of flash overs.
- Smoke venting problems
- Large number of occupants in case of fire, human behavior unpredictable and special care for physically handicapped
- Special care to keep escape routes clear
- Hazards from increasing use of plastic materials, interior finish/decoration

- Multi occupancy hazards, high fire loads
- Inadequate water supplies
- Inadequate/unserviceable fire protection systems and equipment.
- Inadequate openings in glass facade
- Covering of refuge area and putting it for some other use
- Covering of open terraces and refuge areas for use of assembly and restaurants
- Covering and locking of fire staircases/exits
- Excessive use of inflammable materials in interiors
- Modifications in the buildings including change of use after clearance of Fire authorities during initial occupation e.g. adding kitchen.
- Fire fighting equipments and fire detection measures not working

For the last four decades, there had been an ever increasing number of high rise fires, of major proportions and with tragic loss of lives. Some of these major fires have indicated that fires can and quickly exceed the operational capability of even a larger, well equipped fire service. Further, even with fire resistive construction, fire, smoke and toxic gases pose a major threat to the life safety of both occupants and fire fighters.

### **SAFETY FEATURES IN WORLD'S TALLEST BUILDING – BURJ KHALIFA**

Burj Khalifa is the tallest building on the planet. It is a sleek structure that stands some 828 meters (2,716.5 feet) tall, with tip at 829.8 m ,( has observatory at 555.7) m piercing the desert sky of Dubai. A lot of features to take care of the extreme events such as earthquakes, fire, and severe storms have been included into the building's design. It is designed to withstand earthquakes up to 7.0 magnitude against 5.9 magnitude required in Dubai. Provided with a system of motion sensors which has been installed throughout the building, in order to detect and report the unusual structural movements. Burj Khalifa has also recently been connected with a number of tall buildings in the area, which helps to determine when to evacuate highly populated areas so as to reduce the casualties.

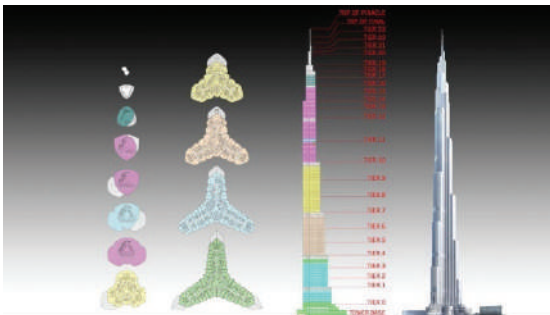

Burj Khalifa piercing the desert sky of Dubai.



Y-shaped buttresses

## Reinforced Stairways and Refuge Areas

In order to give extra safety, the stairways of Burj Khalifa are reinforced with fireproof concrete. However, it is quite unreasonable for the building occupants to walk down 160 flights of stairways in case of a major emergency, this building has got specially constructed refuge areas, which are available on every 25 floors. These refuge areas are separated from the main structure of the building by a “two-hour fire-resistant construction”. It is also air-conditioned and pressurized, in order to mitigate the migration of smoke. These areas are designed on a “defend-in-place” strategy, in which occupants can be easily isolated and protected from the nearby danger, or they are also allowed to stop and catch their breath in a protected environment on the way down in case of a full building evacuation.



hexagonal concrete core with fastest elevators in the world

## The World’s Fastest Elevators

Burj Khalifa has got the “Intelligent elevator installation” as well as the highest elevator in any building to date, it has got a total of 57 elevators and 8 escalators. The average capacity of elevators is 12-14 passengers per cabin, these elevators are also the fastest elevators in the world, having a speed of 10 meters per second. The elevators of Burj Khalifa are situated in the central reinforced fire-resistant concrete core of the building.

## Fire Safety Systems

Sprinkler systems, fire alarms, smoke evacuation systems, and stairwell pressurization are the primary fire safety systems installed in Burj Khalifa building. All these systems are tied with the home automation system which features smart multi-alarm heat, smoke, and optical sensors present in all the rooms throughout the building. This building is also equipped with 38 smoke and fire resistant evacuation lifts.

## CONCLUSIONS

- Life and Fire Safety provisions of NBC 16 must be strictly adhered to ensure life
- Safety and loss of property.
- Due care must be taken that these provisions are not ignored while alterations.
- Based on past experience and research, extra norms must be followed as life of buildings is about

70-100 years.

- Proper maintenance of fire fighting equipments, regular fire drills, availability of
- Evacuation plan and fire order must be ensured.
- No combustible material shall be used and if used, must be treated to alter its combustible properties.
- Clear escape routes must be maintained for emergency.
- Hazardous occupancies must be completely segregated.

## **REFERENCES**

<https://apah.org.in/safety-features-in-worlds-tallest-building-burj-khalifa/>

<http://www.iitk.ac.in/nicee/IITK-GSDMA/F02.pdf>

# MULTI STOREYED HIGH RISE STRUCTURES

Dr. K M Soni, Addl DG (Retd.), CPWD, New Delhi

## Abstract

With rise in population and development growth, agricultural land is going to be scarce due to basic food requirements and Greenfield development hence all the buildings would be multi-storeyed, particularly in metropolitan cities and their suburban areas or satellite cities. In future, even road and rail infrastructure may be developed at multi levels.

The definition of multi storeyed structures is also changing fast. Today, high rise means structures above four storeyed but in coming years another definition will prevail. Terms like mid rise, high rise, skyscrapers and super tall buildings have already been coined up. Mid rise buildings are said to have storeys from 4 to 12, high rise 12 to 40, skyscrapers more than 40 with height less than 300m and super tall multi storeyed buildings exceeding 300m height. Sometimes even term of mega tall buildings is used for the buildings having height more than 600m. This shows the need of high rise buildings almost all over the world.

## Benefits of multi storey buildings

**Some of the benefits of multi storeyed buildings are as given in the following;**

1. Cost effective
2. Aesthetic
3. Quality construction
4. Well ventilated
5. Energy efficient
6. Sturdy
7. Less land coverage
8. Large built up area

It is not always that multistoreyed construction has only benefits, it does have some limitations like higher maintenance and O&M cost, higher requirements of fire safety measures, higher risk of damage in case of failure of structural/non structural members due to disasters etc.

There is a need to adhere to codal provisions for design and safety measures of multi-storeyed buildings simultaneously adopt all precautions and quality control measures from concept stage to maintenance stage of such structures.

## **Important Points to be considered in Multistoreyed Construction**

Some of the points required to be considered are discussed briefly.

### **Geotechnical Investigation**

Geotechnical investigation is carried out before the work is executed i.e. immediately after the layout of the building is finalized. A multi-storeyed structure in most of the cases requires raft or pile foundation due to heavy load of the structure. The properties of soil which are required to be considered will be anywhere upto 15m or more. Normally, the soil properties below 15m may be almost constant hence soil properties minimum upto 15m are to be evaluated. Therefore, the depth of soil investigation should not be restricted to shallow depth but minimum around 20m or more until rocky profile is met with.

### **Provision of Basement(s)**

Since the foundation of multistoreyed construction requires raft or pile foundation and with depth bearing capacity of soil generally increases, it is recommended to design basement(s) in case of such structures. This also makes construction cost effective as basement construction has two advantages, one it creates useful space and second reduces the requirements of heavy footings. Higher bearing capacity at lower depth reduces cost of foundation and in case of pile foundation reduces length of piles and as such foundation becomes economical. Since basement soil is removed, it also results in less loading compared to those structures having no basements on similar conditions. In case of filled up soil, basements help in removal of such soil. Basement also provides additional space for services.

### **Diaphragm wall and Retaining wall construction**

In multi-storeyed construction due to space constraint and existing adjoining structures, diaphragm wall construction is required. Once diaphragm construction is done, retaining wall may also be required. Such construction becomes costly. Sometimes, the space between diaphragm wall and retaining wall (basement wall), is kept vacant. In case, the water enters into the space, it behaves like a water tank and affects durability of diaphragm wall and retaining wall and even may lead to leakage into the basement. Therefore, either this should be used with proper maintenance or filled up with soil.

### **Post Tensioned Slabs**

Due to higher depths of beams in conventional construction, and to accommodate air conditioning ducts or otherwise to have desired headroom, storey height is to be increased in conventional cast in situ construction. In case post tensioned (PT) slabs are adopted, it avoids beams and with same height of the building, more number of storeys can be accommodated as it avoids beams or increases headroom to accommodate air-conditioning ducts hence PT slab construction should be adopted in high rise construction for economy.



### Masonry Work

Conventionally, brick masonry with clay or flyash bricks is used in masonry work in RCC framed structures though at some places cement concrete block masonry has also been used. Such structures make the structures heavy leading to heavy columns, beams and foundation. In case, AAC blocks (Density @ 550 to 600 kg/cum) or panels of EPS blocks (Density 11 to 32 kg/cum) or similar materials are used, it results into light weight structure.



### Cladding

Many a times, cladding is provided with stones or tiles. Stones are supported on small anchors/pins without any mortar and as such if anchors or pins come out of the stone, it may fall down and pose safety problems hence supporting arrangement has to be designed properly else cladding should be avoided. Stone cladding should not be provided on brickwork/blockwork as the anchoring arrangement is likely to come out and should be supported only on shear walls. In case, cladding is required on brickwork/blockwork, tile cladding or ACP cladding should be done.



### **Water Supply Arrangements**

Water supply in high rise structures is required to be designed properly as the pressure in lines may go very high in lower floors leading to bursting of lines and fittings while pressure in upper floors may get reduced. Therefore, pressure reducing valves are to be fitted as per the requirements on each floor. Services in multi-storeyed structures should be designed and not adopted on thumb rule basis.

### **Parking and Essential services**

Parking is being designed in basements in most of the multi-storeyed structures and will continue. In future, robotic parking will be essential for skyscrapers and tall buildings. Many underground services would also be designed like metros, sub stations, markets, departmental stores etc with connectivity of parking of large campuses of multi-storeyed structures.

Helipads on rooftop may be another essential requirements of skyscrapers and super tall buildings for emergency requirements like fire evacuation, medical emergency, law and order requirements hence architects and engineers will have to include it in the designs.

### **Energy Efficiency**

Multi storeyed construction may require lifts, pumping of water, air conditioning etc and thus have high energy demand during operation and maintenance stage. Hence energy conservation and energy generation have to be given high importance during its design and construction. Three pronged strategy should be adopted as energy conservation by adopting energy efficient architectural design, installing energy efficient equipment and gadgets, use of solar power in the building itself and adopting energy efficient building materials, and conserving energy as much as possible by operating equipment at optimum temperatures and making use of natural resources. Use of facade of the building for receiving solar heat and converting into power and also storing it for later use will have to be researched. At present, there are various methods by which solar energy can be harnessed and as such all multi storeyed buildings are to be designed accordingly. Advantage of such buildings is that solar heat is easily available on most part of the building envelope due to height .

## **Safety**

Safety in high rise structures need structural safety, workers safety during construction and maintenance, safety from falling components, fire safety, intrusion safety and safety from lightening etc. There have been many instances in the country of failure of high rise structures like in Bhuj earthquake and as such in earthquake zones IV and V, we should switch over to base isolation techniques soon. Internal services and interiors are also required to be designed for earthquake conditions.

Fire incidences in high rise structures in Mumbai have resulted into heavy damages due to flames and smoke and as such top priority is to be given in high rise construction for fire safety and all the NBC norms followed with due clearances obtained from fire authorities. The users have to be sensitive not to change use of spaces and keep the services always in working conditions.

Safety from falling objects may become another major issue in India in high rise structures for example users are in habits of opening the windows. Therefore, there is a possibility of falling glass or some other materials from a height and as such safety precautions should be built in architectural design and arrangements made to maintain the services.

## **New Construction Technologies**

New construction technologies are always adopted in high rise structures due to quality, safety, economy, technological requirements and speed required for construction and maintenance. In India also, new technologies like monolithic construction using jump formwork, aluminium formwork, tunnel formwork or stay in place formwork are adopted. Steel, composite and hybrid structures will be adopted in high rise construction in future. Due to space constraints, pre fab/pre cast construction is likely to gain momentum.

## **Easy Maintenance**

Maintenance of high rise structures is costly compared to conventional low rise buildings. It is observed that maintenance cost or service charges are always more in such cases and with rise in specifications and services, cost also goes up. Maintenance of services is very important in high rise structures and staging platforms are to be provided for maintenance staff. In future, robotics may replace manual maintenance. Maintenance cost of services, service shafts, and building facade is more in case of multi storeyed structures and thus building has to be designed in such a way that it requires less maintenance.

## **Use of Information Technology (IT)**

Use of IT is going to be included in planning and construction of multi storeyed construction for architectural design, structural design, and MEP designs, operation and maintenance. Building Information Modelling (BIM) has already become almost a necessity due to many advantages. IT will take over edge in construction, monitoring and maintenance also in multi storeyed buildings. All the controls in multi storeyed structures will be automatic and IT controlled. In future, these may be robot operated due to safety considerations. Smart services, robotic parking, smart equipment and smart building concept will be adopted in case of multi storeyed buildings.

## **Concluding Remarks**

Multi storeyed construction is a must in India for all types of buildings in cities and even in small cities and towns to preserve agricultural land for sustainability. The challenge is in its safe durable design and green construction requiring least maintenance for which new construction technologies, mechanization, IT, robotics and smart equipment will have to be adopted in design, construction and maintenance suiting to various climatic conditions of the country. Capacity building in architects, engineers and contractors is immediately needed to cope up such future requirement.

## **Reference**

<http://www.alcox.in/blog/multi-storey-buildings-classification-benefits/>

1. Soni, K M (2018). Post Tensioned Construction Technology for Multi-Storeyed Buildings. CE&CR, Vol. 31(3), 63-68.
2. Soni, K M (2018). New Materials and Techniques in Construction of CBI Office in Mumbai. CE&CR, Vol. 31(2), 54-56.
3. Soni, K M (2019). High Rise Structures - Consideration of Benefits and Limitations, CE&CR, Vol 32(9), 26-28.

# RESURGENCE OF VERTICAL ARCHITECTURE IN INDIA

**Ar. Dikshu C. Kukreja**

M. Arch (Urban Design), Harvard University, USA

Managing Principal, C. P. Kukreja Architects, New Delhi

*Ranked amongst the top 100 Architecture firms in the world*

*Shikharas, Stambhs, Gopurams and Darwazas* are historical architectural marvels which have dotted the skylines of various cities across India for centuries. The use of these robust and magnificent elements of design, soaring in height and grandeur in their detail, have also been of immense significance in our culture. Often towering edifices can be deemed as important milestones in the journey of high-rise architecture. If one were to engage in a historical architectural discourse of India, they would realise that the origin of these marvels is native to the country. In this sense, it demonstrates how India was already pacing ahead in time with its pioneering engineering innovation and astounding architectural imagination than its Western counterparts.



*Amer Fort structures the skyline of Jaipur*



*Virupaksha Temple in Hampi, with its magnificent horizontal and vertical scale, dominates Karnataka's skyline*

A glance at these structures and one is awestruck and overwhelmed with the level of detailing and embellishment which the Architects and Engineers were undertaking at the time. Unlike the monotonous and banal high-rise towers that dominate the skylines of major metropolises today, the grandeur and glory exhibited by ancient edifices such as the Gopuram of Madurai, the Kirti Stambh in Chittor Fort and the Sun Temple in Konark, to name a few, is par excellence. With sculptures and paintings imbedded in the core of the design, these tall structures impressed the viewer with quality of aesthetic inventiveness.



The Kirti Stambh in Chittor Fort is a 22-metre-high tower and was built in the 12<sup>th</sup> Century



Kumbhalgarh Fort in Mewar was constructed in the 15<sup>th</sup> Century.



*Interestingly, the fortress wall of the Kumbhalgarh Fort is the second longest in the world, after the Great Wall of China, spanning 36 kilometres in length*



*Intrinsic detail of the Gopuram at Chamundeshwari Temple in Mysore which was built in the 12<sup>th</sup> century by the Hoysala rulers*

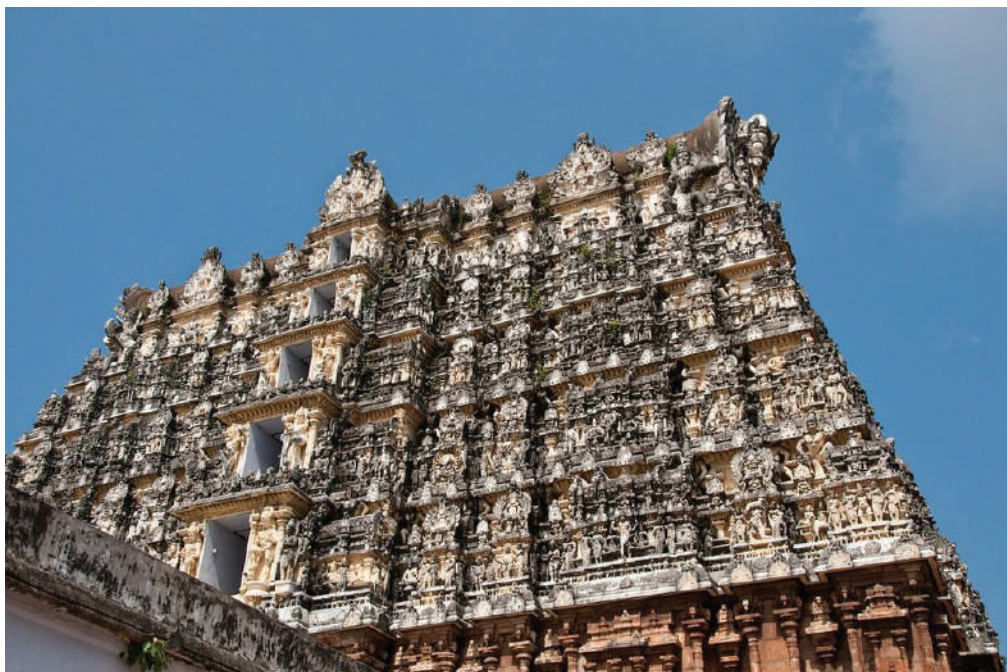

*Constructed in the 6<sup>th</sup> Century, the entire icon of the Padmanabhaswamy Temple in Kerala is carved out on a massive stone measuring 20 feet high and 2.5 feet thick*

With the arrival of Mughals and the British, a new language of architecture arose in the country, visibly culminating the era of vertical architecture. While the Mughals brought with them concepts such as the Mughal Gardens and elaborately spread low-rise, high density cities, the Colonial Architecture of the British leaned towards designing utilitarian buildings and colonies. It is safe to assume that these subsequent regimes might have been a little overawed by the vastness of land in the country, which led them to resort to a horizontally laid design and master planning. This resulted in developing cities as urban sprawls, spread over hundreds of acres of land.



*Shahjahanabad, 1857*



*Present day Shahjahanabad?*



*A panoramic view of the Blue City of Jodhpur and the imposing Mehrangarh Fort dominating its skyline*

Even after Post-Independence and Partition, the same design legacy continues to follow till this day, visible in the planning of metropolises such as Kolkata, New Delhi and Lucknow. The growth in Indian economy, thereafter, reflects in urban migration which continues to happen in large volumes across the country. In this search of a better livelihood, improved amenities and a secured future, we have perhaps forgotten that land continues to be a limited resource. Today, our country inhabits almost 1/5<sup>th</sup> of the total population of the world and continues to grow at a steady pace. With a burgeoning economy of this demeanour, our cities are buckling under the pressures of growth and development. High-rise design offers a viable solution, then, in present times and optimizes the limited land resource at hand. With this, the country seems to be coming full circle, ready to embrace its forgotten historical vertical architecture.



*The detailed works seen on the Meenakshi Temple in Madurai exhibit the bold use of art in architecture*

In an era of globalization, especially after the surge in real estate demand during the 90s, the Architects turned to Western countries to seek inspiration and in doing so, blindly aping their concepts of high-rise architecture.



*For The Lalit & World Trade Centre, located in the posh area of Connaught Place, C P Kukreja Architects (CPKA) adopted using a combination of Dhoolpur and Agra stones which were sourced locally. The design continues to be lauded for its sensitive design approach as well as the pioneering engineering solutions it offered through the project at that time.*



*High-rise development offers quick solution to the problem at hand but mindlessly aping the West has damaged the character of cities and created silos of isolation*

However, the time has come where the needs and challenges of the citizens seek to be addressed and resolved with solutions that best fit the economy, climate, geography and culture of our country while carving a distinct identity. For this, we need to look at and propose unique architectural solutions.

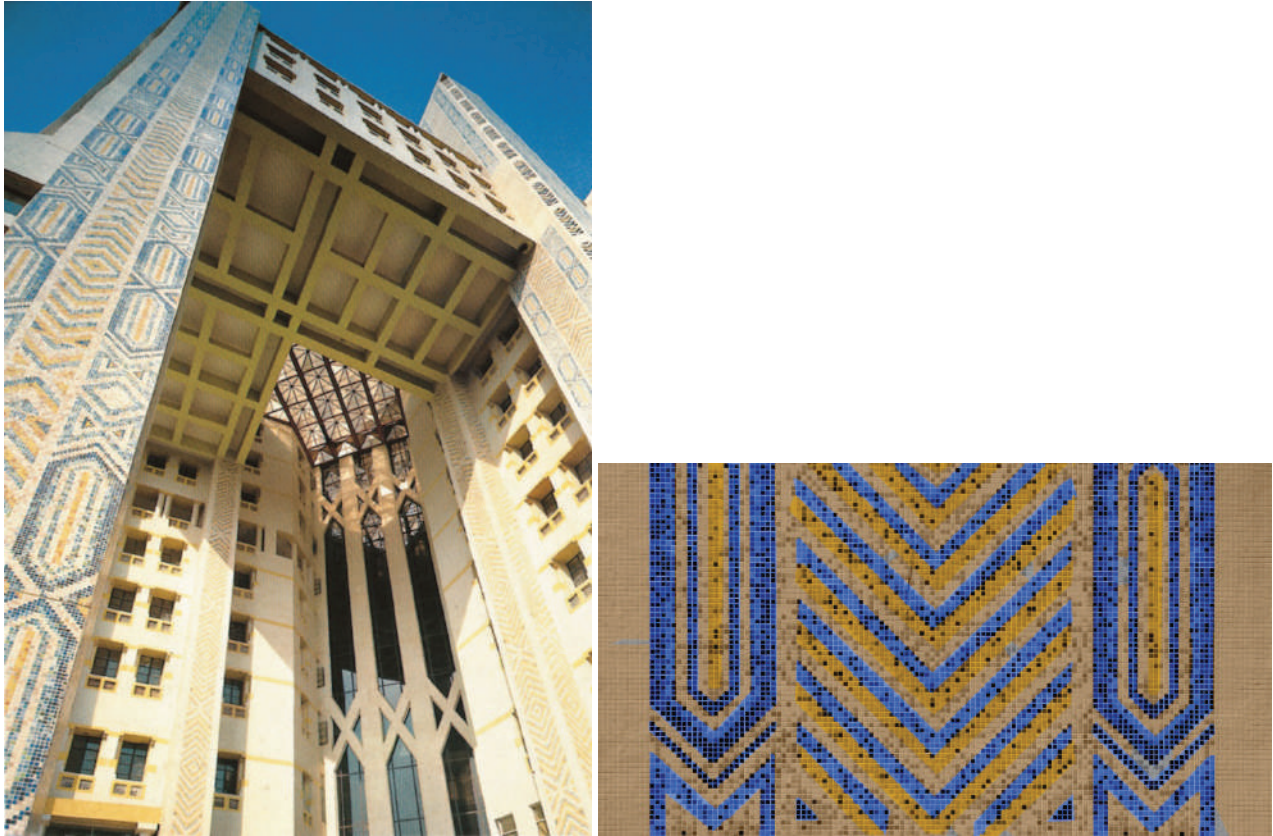

*Amba Deep Towers, designed by CPKA in 1993, achieved landmark status by imagining the complete edifice as a canvas using intrinsic glass mosaic patterns which created a distinct record of art at the largest (and tallest) scale ever created in the city.*

Current times also present the opportunity to utilize advanced technology as an effective tool to increase the efficiency of construction in terms of cost, use of resources, time and materiality to best suit the location. Ironically, India being one of the few elite nations which has achieved global prowess in engineering sectors such as Information Technology, Space Technology etc. and with institutions such as the IITs, the construction and building engineering continues to witness a conservative approach. We have the resources, potential and opportunity to develop a one-of-its kind technology which meets the requirements best suited for our country. It becomes imperative, then, to push our boundaries and reform our mindset and through it achieve aesthetically pleasant as well as strong design solutions.



*Boston's high-rises are a repetitive mass of development*

Another highly important aspect which needs to be ensured is the planning of these high-rise edifices. India is a vibrant country where social interactions amongst communities and extended families form the ethos. In such a scenario, one cannot design vertical towers, as seen in the case of western counterparts, with floors stacked one above the other, and are replicated in their internal planning with no area for shared community interaction. We should, therefore, rework design paradigms which inculcate the values of Mohallas, chowks, aangans in their ideation so as to avoid a sense of being trapped in chambers of isolation.



*East Delhi 'Transit-oriented development' Hub, a mixed-use project of CPKA, conceptualised the use of 'organic density' as a tool for spontaneous adaptation to environmental and economic diversity, and as an auto-adjustable controlling measure for the population influx and activities within the urban complex. With a proposal of design of a 100-storeyed Tower, tallest in country, the Architects have imbibed elements such as aangans on different floors to create shared recreation spaces.*



*Abundant foliage is interspersed in the landscape, creating harmonious and socially thriving neighbourhoods (East Delhi Hub, C P Kukreja Architects)*



*Khajuraho Temples with aangan (large open area) in its foreground and a series of repetitive columns which acts as a perforated screen whilst imparting a one-of-its kind architectural character*

These ideas should be able to seamlessly adapt to different requirements- from affordable housing to luxury apartments or from BPOs to Multi-National Companies. Going forward, it is also of vital importance that we are sensitive towards sustainable design and engineering. Incorporating renewable sources of energy which use wind and solar resources along with regulation of daylight and natural ventilation can be helpful in breaking away from the perception of high-rise buildings being energy guzzlers, as witnessed in the 20<sup>th</sup> Century. Again, by understanding our own climatological needs and not blindly copying the West to erect greenhouses and instead, using vernacular design elements such as *chajjas* (cantilevers), *jaalis* (perforated screens) and water bodies that have worked well for Centuries, our tall buildings can help curate a new experiential living, native to our country.



*Channels were planned to preserve and conserve rainwater as seen in the Chittor Fort*



*Rainwater conservation within the building's premises is also effective strategy to naturally regulating temperatures as seen here at the Shore Temple in Tamil Nadu*



*Stepwells, used for water storage, showcase the futuristic design planning and an incredible engineering prowess achieved at that time*

As we move away from the romantic and elaborately laid out planning of yesteryear's Shahjahanabad towards high-rise development, there needs to be a reinvention of high-rise design. Accepting the movement towards high-rise design as an inevitable and unavoidable phenomenon, we need to create new paradigms for our cities which shall embrace an Indian identity reflective of our culture and society.

# SEISMIC CONTROL SYSTEMS

Er. D S Panwar, Executive Engineer, CPWD, Guwahati

## Abstract

Earthquakes remain largely unpredictable and potentially catastrophic, a matter of continuous concern to communities in affected zones. Scientists and engineers have made considerable effort to mitigate their consequences through the design of effective protective devices. Seismic control systems are modern techniques in Earthquake Resistant Design that prevent or divert a major portion of earthquake energy from entering into the main structural system of the structure by applying various techniques

## 1.0 Seismic Resistant Design

Seismic control systems are modern techniques in Earthquake Resistant Design that prevent or divert a major portion of earthquake energy from entering into the main structural system of the structure by applying various techniques. Generally there are three types of seismic control system:

1. Active seismic control system
2. Passive seismic control system
3. Hybrid seismic control system

### 1.1 Active seismic control system

This system provides seismic protection by imposing forces on a structure that counter balance the earthquake induced forces. This system is active as it requires an energy source and computer controlled actuators to operate special braces or tuned mass dampers located throughout the building. Active system is more complex than passive system since it relies on computer control, motion sensor, feedback mechanism, and moving parts which may require service or maintenance. Active seismic control system also needs an emergency power source to ensure that it will be operational during a major earthquake and any immediate aftershocks.

Active seismic control is comparatively newest invention in the field of seismic control systems that applies a three dimensional network of counter balancing hydraulic operated weights that are controlled by sensors. When an earthquake hits the buildings, sensors located within the building determine the direction and weight of counter balancing systems that is to be moved in an opposite direction to that of earthquake induced motion, so that building remains motionless, hence causes no damage at all to the building. This technology is highly sophisticated and expensive and may not be feasible for small projects even in for future.

### 1.2 Passive control system

Passive seismic control systems are passive as these systems do not required any additional energy source to operate and are activated by the earthquake input motion only. Some examples of passive control system are as under:

- Energy dissipation devices
- Base isolation techniques
- Dynamic oscillators

### **Energy Dissipation Devices**

Energy dissipation devices are the specially designed mechanical systems to dissipate a large portion of the earthquake input energy in specialized devices or special connection details which deform or yield during earthquakes. In general, energy dissipation devices are characterized by its capability to enhance energy dissipation in structural systems to which they are installed so that the structure has to resist lesser amount of earthquake induced forces. Energy dissipation devices operate on principles such as friction sliding, yielding of metals, phase transformation in metals, deformation of visco-elastic solids or fluid and fluid orficing in fluid viscous dampers. Following types of energy dissipation devices are used:

- Friction dampers
- Metallic Yielding dampers
- Visco elastic dampers
- Fluid viscous dampers

Safety of structural system is hence achieved, basically by conversion of mechanical energy induced in the structural system into the thermal energy within these energy dissipation devices installed. The entire process is also known as Damping as energy of the vibrating structure gets dissipated out of the main structural system at these Dampers in form of heat which ultimately gets transferred to the surroundings.

Addition of energy dissipation devices enhance the damping characteristic as a result of which amplitude of motion of the structure is dampened significantly immediately after the initiation of ground motion or after the exceed once of structural motion's threshold, thereby reducing the forces on structural members. Enhancement of damping is gaining a wide popularity and is established as a major approach in earthquake resistant design.

### **Base isolation technique**

Isolation of an entire structure's motion from the shaking ground below using flexible interface between the structure and its foundation is another powerful technique which is called base isolation technique.

### **Dynamic Oscillators**

Transformation of energy among the vibrating modes by means of Dynamic Oscillators is another example of Passive Seismic control system This method includes supplemental oscillators which act as dynamic absorbers.

Tuned mass dampers (TMD) fall in this category, TMD, with its frequency of vibration tuned to the exciting frequency is attached/ connected to the main structural system. During excitation, TMD simply moves in out of phase to that of the main structural system thereby imparting opposing inertial forces to that of the external vibrating forces acting on the structure, while doing so TMD is simply maintaining its inertia property.

### 1.3 Hybrid seismic control system

This system combines features of both passive and active seismic control systems. In general it has reduced power demands, improved reliability and reduced cost when compared to fully active system.

### 2.0 Base Isolation technique:

Isolation of entire structure's motion from the shaking ground below using flexible interface between the structure and its foundation is called base isolation.

Basic principle of seismic base isolation is to increase the structure's natural time period leading to decrease its natural frequency of vibration to that of its corresponding fixed based structure and that of the predominant period of soil at the site too.

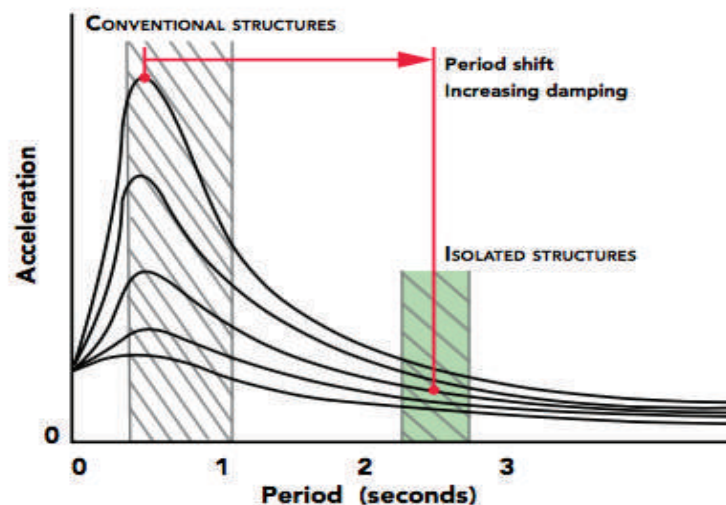

Base isolation uses base isolator layer at its base that has high stiffness along the vertical direction but low lateral stiffness. The isolation system shifts the fundamental time period of the structure to a large value and dissipate the energy in damping, limiting the amount of force that can be transferred to the superstructure. In this way, the superstructure can be decoupled from earthquake induced ground motions and its tremendous energy. Decrease in frequency of vibration also decreases the pseudo acceleration of structure thereby reducing the base shear.

Base isolated buildings have much longer first mode time period of vibration than its fixed base structure. The higher modes are essentially not excited by the ground motion, although their pseudo acceleration are large, because their modal static response are very small. The primary reason behind the effectiveness of base isolation in reducing earthquake induced forces in a building is the lengthening of the first mode period.

In context of seismic design of structures, base isolation can be replaced with seismic isolation i.e. the structure above the ground, which is most affected during earthquake is separated from the effects of earthquake forces by introducing a mechanism that will help the structure to hover. The concept of base isolation is quite easy to grasp. It can be explained as a bird flying during an earthquake is not affected. In simple words if structure is floating on its base, the movement of ground will have no effect on the structure.

## 2.1 Purpose of Base Isolation

Wind and Earthquake are the most predominant loads that demands lateral design of a structure. Again, earthquake load is not controllable and it is not practical to design a structure for an indefinite seismic demand. Only practical approach left is to accept a demand and make sure the capacity is more than the demand. The inertial forces caused due to earthquake is directly proportional to the mass of structure and the ground acceleration. Increasing ductility of the building or increasing the elastic strength of the structure is the most conventional method of handling seismic demand. Engineer has to increase the capacity exceed the demand.

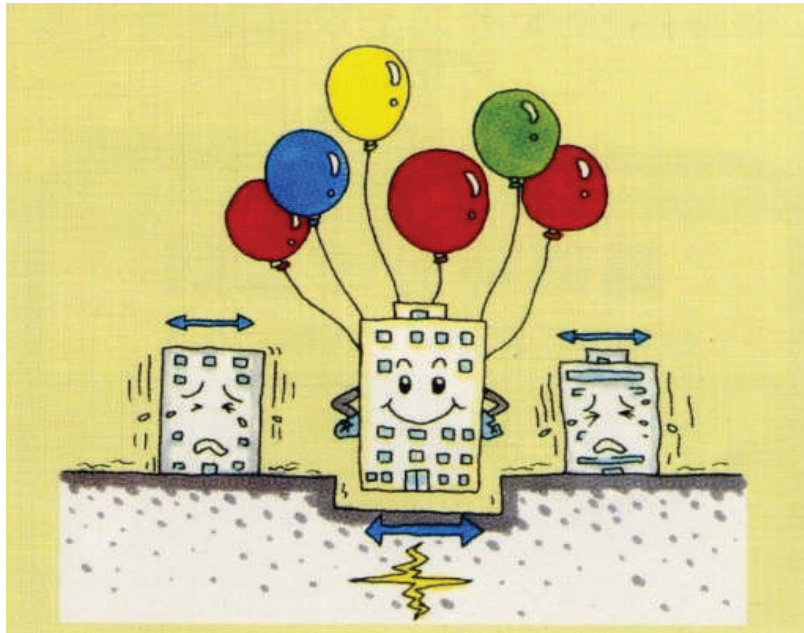

Logic of Base Isolation

Base isolation takes an opposite approach, i.e. to reduce the seismic demand instead of increasing the capacity. Controlling ground motion is impossible, but we can modify the demand on structure by preventing/reducing the motions being transferred to the structure from foundations.

## 2.2 Principle of Base Isolation

The basic principle behind base isolation is that the response of the structure or a building is modified such that the ground below is capable of moving without transmitting minimal or no motion to the structure above. A complete separation is possible only in an ideal system. In a real world scenario, it is necessary to have a vertical support to transfer the vertical loads to the base.

The relative displacement of ground and the structure is zero for a perfectly rigid, zero period structure, since the acceleration induced in the structure is same as that of ground motion. Whereas in an ideal flexible structure, there is no acceleration induced in the structure, thus relative displacement of the structure will be equal to the ground displacement.

No Structure is perfectly rigid or flexible, therefore, the response of the structure will be between the rigid and flexible. Maximum acceleration and displacements are a function of earthquake for periods between zero to infinity. During earthquakes there will be a range of periods at which acceleration in the building will be amplified beyond maximum ground acceleration, though relative displacements may not exceed peak ground displacements. Base isolation is the ideal method to cater this, by reducing the transfer of motion; the displacement of building is controlled.

Displacement occurs at CG of the structures for fixed base structures, which will be approx. two-third height for buildings and at isolation plane for base isolated structures with lesser displacement within the structure. The response of a base isolated structure and a structure without base isolation can be illustrated as shown in the figure below. The displacement and acceleration is controlled by base isolation.

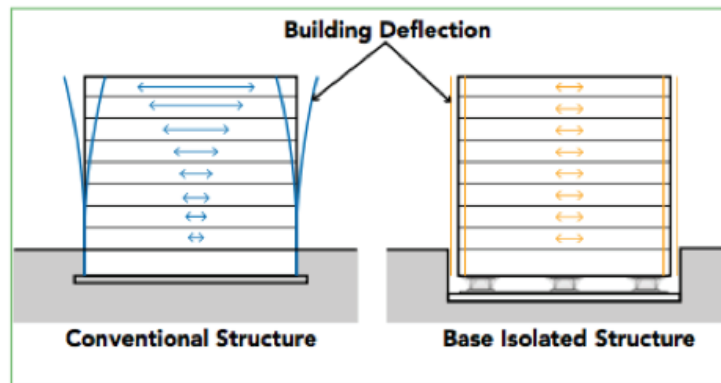

Response of base isolated & non-isolated structure

### 2.3 Basic requirements of an isolation system

- Flexibility
- Damping
- Resistance to Vertical or other service loads.

### 2.4 Type of Base Isolation Systems

Earthquakes cause inertia forces proportional to the product of the building mass and the ground accelerations. As the ground accelerations increases, the strength of the building must be increased to avoid structural damage. It is not practical to continue to increase the strength of the building indefinitely. In high seismic zones the accelerations causing forces in the building may exceed one or even two times the acceleration due to gravity, it is easy to visualize the strength needed for this level of load, which

means that the building could be tipped on its side and held horizontal without damage. Base isolation is one of the most widely accepted techniques to protect structures and to mitigate the risk to life and property from strong earthquakes. Earthquakes will happen and are yet uncontrollable; so it should be tried to increase the capacity

Base isolation system should be capable of restraining the structure under strong gust of winds and gravitational pull. Though an ideal solution is yet to be discovered or invented, there are a few practical isolation mechanisms which are widely used in the field of earthquake engineering. Which means that these systems are capable of reducing the seismic demand of the structure.

### Major types of Isolators

- Elastomeric Bearings
- High Damping Bearings
- Lead Rubber Bearings
- Flat Slider Bearings
- Curved Slider Bearings or Pendulum Bearings
- Ball & Roller Bearings

#### 2.4.1 Elastomeric Bearings

Bearings formed of horizontal layers of synthetic or natural rubber in thin layers bound between steel plates. These bearings are capable of supporting high vertical loads with very small deformations. These bearings are flexible under lateral loads. Steel plates prevent the rubber layers from bulging.



Elastomeric Bearing Pad Laminated bearings with profiled outer steel plates

Lead cores are provided to increase damping capacity as plain elastomeric bearings does not provide significant damping. They are usually soft in horizontal direction and hard in vertical direction.

## 2.4.2 High Damping Bearings

High damping rubber bearing, also known as HDR, has very similar appearance to lead rubber bearings, but they are totally different in nature. High damping rubber bearing is composed of special rubber with excellent damping attribute, sandwiched together with layers of steel without any lead plugs.

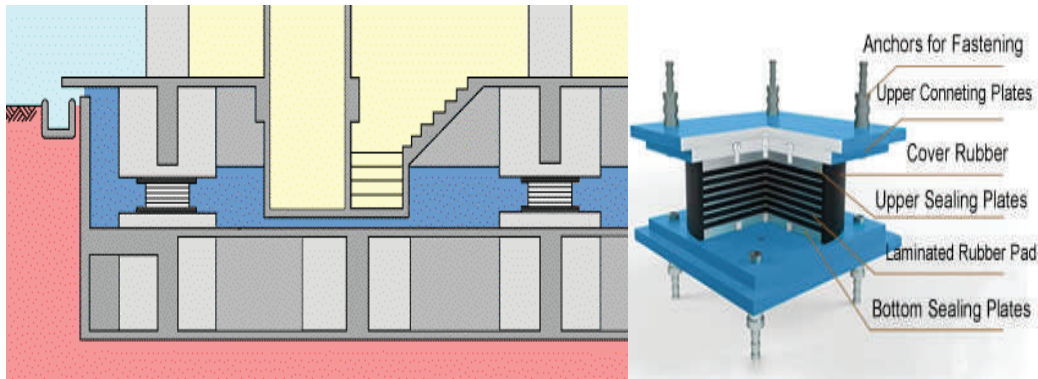

A high damping rubber bearing is very stiff in nature, however, during earthquake, it becomes very flexible in horizontal direction so that they can reduce the earthquake force upon the building or bridges by changing its own shape. Most of all, it can spring back to its original shape after earthquake owing to high elastomeric property.

## 2.4.3 Lead Rubber Bearings

Lead rubber bearing, applied to building and bridge constructions, is a practical and cost-effective choice for seismic isolation. It is composed of laminated elastomeric bearing pad, top and bottom sealing & connecting plates and lead plug inserted in the middle of the bearing.

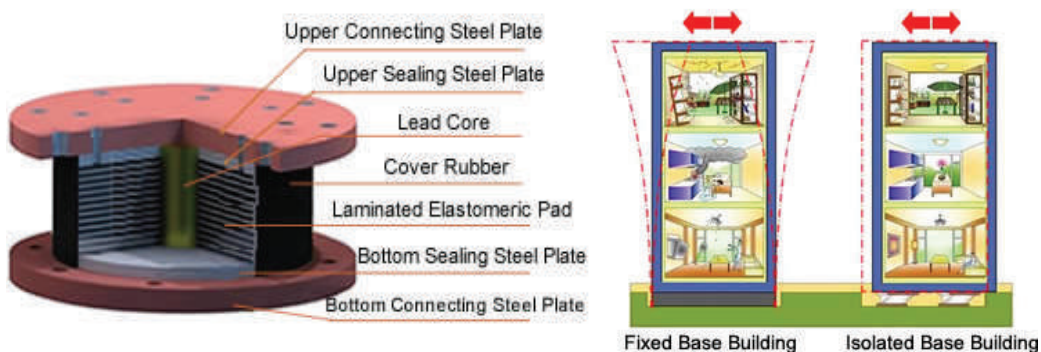

During the earthquake, the un-isolated building will vibrate back and forth in varying directions due to the inertial forces and result in deformation and damages of the building. In contrast, the base isolated building will also displace but remains its original shapes and avoid damages - that is because the lead rubber bearing effectively dissipates the inertial force upon the building, extends the building's period of vibration and decrease the acceleration of the building.

The lead plug will slide with laminated rubber during earthquake but convert this energy of movement to heat so that it efficiently reduces the inertial force upon the building, which slow the vibration of the

building. Meanwhile, the rubber part will preserve its original shape due to high elasticity.

### 2.4.4 Flat Slider Bearings

Sliding systems with a predefined coefficient of friction can provide isolation by limiting acceleration and forces that are transferred. Sliders are capable of providing resistance under service conditions, flexibility and force-displacements by sliding movement.

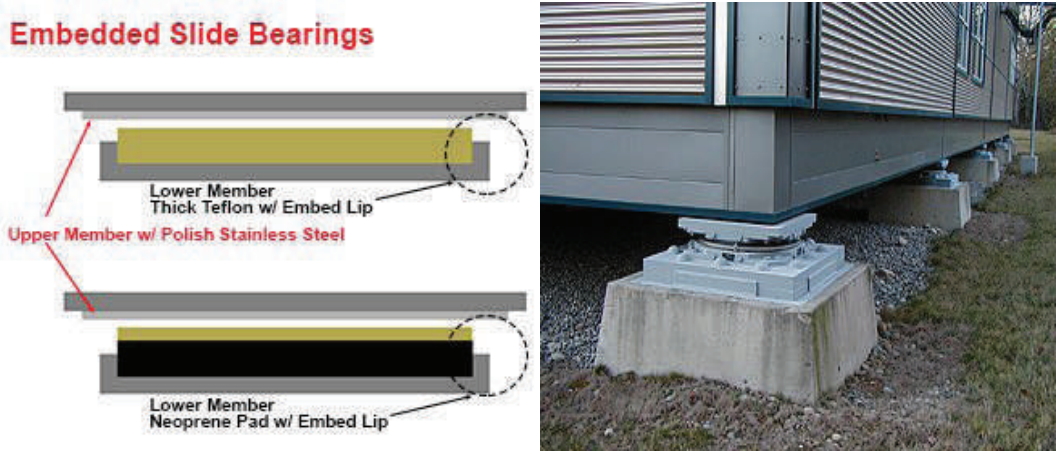

Shaped or spherical sliders are often preferred over flat sliding systems because of their restoring effect. Flat sliders provide no restoring force and there are possibilities of displacement with aftershocks.

### 2.4.5 Pendulum Bearings

Sliding friction pendulum isolation system is one type of flexible isolation system suitable for small to large-scale structure. In recent years, the Friction Pendulum System (FPS) has become a widely accepted device for seismic isolation of structures. The concept is to isolate the structure from ground shaking during strong earthquake.

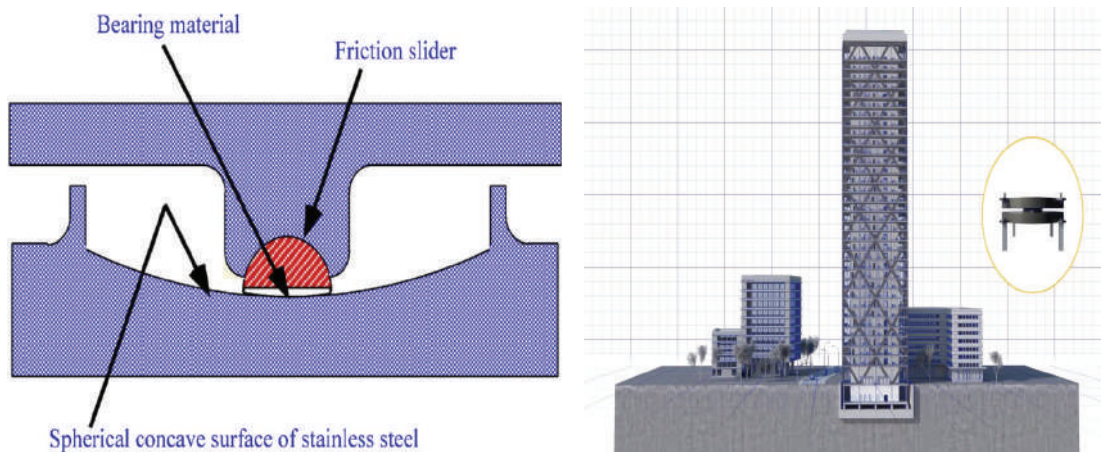

Seismic isolation systems like the FPS are designed to lengthen the structural period far from the dominant frequency of the ground motion and to dissipate vibration energy during an earthquake. The sliding properties of the surface materials are key for the performance of the isolation system. The FPS consists of a spherical stainless steel surface and a slider, covered by a Teflon-based composite ma-

terial. During severe ground motion, the slider moves on the spherical surface lifting the structure and dissipating energy by friction between the spherical surface and the slider. This isolator uses its surface curvature to generate the restoring force from the pendulum action of the weight of the structure on the FPS.

### 2.4.6 Ball and Roller Bearings

For isolation applications in machinery isolation, roller and ball bearing are used. It includes cylindrical rollers and balls. It is sufficient to resist service movements and damping depending on the material used.

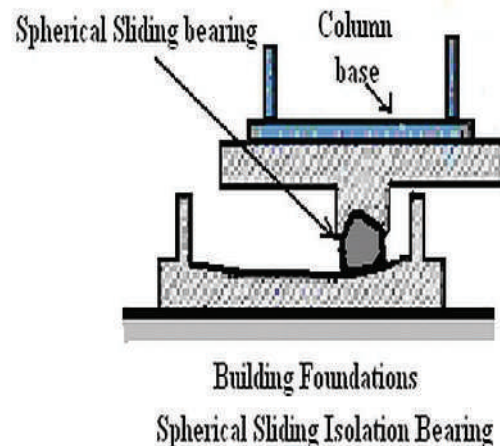

### 3.0 Advantages of base isolation

- It reduces floor acceleration and inter storey drift.
- Less (or no) damage to structural members.
- Better protection of secondary systems.
- Prediction of response is more reliable and economical.

### 4.0 Disadvantages of base isolation

- Base isolation can't be done on every structure, for example: it is not suitable for structures resting on soft soils.
- Becomes less efficient for high rise buildings.
- Unlikely other retrofitting base isolation cannot be applied partially to the structure.
- Implementation in efficient manner is difficult and often requires highly skilled labours and engineers,

### 5.0 Applications of base isolation

- First application in New Zealand in 1974.
- First application in US in 1984.

- First application in Japan in 1985.
- First application in India in 2003.
- LA city hall (height 138m) in Los Angeles is the tallest base isolated building in the world.
- The 300 bed Bhuj Hospital that claimed 176 lives when it collapsed during the major January 2001 Gujarat Earthquake was the first new building in India to be fitted with earthquake – resistant NZ developed base isolation technology.

## 6.0 Conclusions

- Seismic base isolation method has proved to be reliable method of earthquake resistant design.
- The success of the method largely attributed to the development of isolation devices and proper planning.
- It is cost effective for new constructed building, its initial cost is higher but in major earthquake there is less non structure damage.
- The system not only protects people and infrastructure from damage by seismic activity but sometimes can also reduce overall expenditure by cutting the cost of construction of extra strengthening measures and maintenance.
- The field of engineering is as dynamic as the world we live in and so is the requirement of the innovation in the construction industry. One such innovation is Base isolation system.

## References

- Sarvesh K. JAIN and Shashi K. THAKKAR, "Application of Base Isolation for Flexible Buildings", *Proceedings of the 13th World Conference on Earthquake Engineering, Canada, 2004, Paper no. 1924*
- DELFOSSE G. C, "THE GAPEC SYSTEM: A new highly effective aseismic system", *Proceedings of the VI World Conference on Earthquake Engineering, New Delhi, 1977*
- P. P. ROSSI, P. LENZA and M. PAGANO, "Base Isolation Strategy for Framed Buildings", *Proceedings of the 11th World Conference on Earthquake Engineering, Paper no. 1345*
- Oladeinle MH, Edokpia RO, Unulgbé, AI- A study of static performance of fixed inclined slide bearing-A power law model
- Nirav G Patel- Study on a base isolation system.

# SAFETY CHALLENGES IN HIGH RISE BUILDINGS AND WAY FORWARD

Dr. Sanjai Kumar Srivastva, EHS Head North

L&T Construction, Buildings and Factories IC



## Introduction:

Growing needs of people and fast urbanization have raised the demand for construction of the high rise buildings in cities; as horizontal development is having its own constraints due of high cost and limited land, thus vertical construction is one of the viable option for meeting the demand of houses for millions for the country like India to meet the rising needs and expectations of people. Thus exponential growth in construction of high rise building has been witnessed in recent years.

We have seen the development of technology in most of the sectors, construction work is still labour intensive, based on information available in the public domain, around 53 million people are engaged in construction activities across India and, by 2030, India is expected to be the third largest construction market globally which is next to agriculture. Modern architectural ideas are soaring to new heights and cities are growing unbelievably taller and taller every day.

Due to its inherent linkage with other sectors, its contribution is nearly 7.9% of total GDP, which is very significant.

The issue of making human lives more secure remains central, as it is the human being for whom all these modern cities are being created. What type of norms and regulations will define safety standards, what technology will protect people living and working at such enormous heights? Again and again we are faced with fire at high rise buildings resulting in enormous loss of valuable lives, documents and properties. While approving high rise buildings, which are a necessity in growing metropolis short of space, the issue of overall safety measures has not been adequately addressed. It is high time that all stakeholders put their heads together to find realistic and implementable solutions to make living and

working safe.

Various past studies have revealed that even in industrialized countries, construction remains an extremely dangerous occupation. Construction workplaces keep changing, almost daily due to the inherent nature of construction activities, thus posing serious hazards to employees and workmen alike. The inherent activity-related risks/hazards such as working at height, casual attitude, ignorance, and exposure to inclement weather, required skill sets, poor literacy levels and the like can be mitigated by involving individuals with active management support

The improvement of safety levels in high rise buildings is in the interest of everyone and requires combined efforts of government officials, private security agencies, professionals and every member of the society. Therefore, it is very important to establish a networking platform for building proper structures, providing dependable equipment, training all concerned and for speedy information exchange among all stakeholders, dealing with, working and living in high rise buildings. There is also a serious potential of fires due to the storage and use of flammable substances and a potential for disasters due to collapse of the structures and subsidence of the soil on which the construction activity is being carried out.

The number of fatalities at work in the construction sector remains a matter of serious concern for the Government, employers.

### **Safety issues in High rise buildings:**

Taking cognizance of the data on types of accidents in the Indian industry, of the 130 deaths every single day due to occupational accidents across various sectors, 38 occur in the construction sector alone! Each precious human life lost impacts not only the families but the society as well. The only way to stop this agonizing loss is to constantly develop and upgrade our systems and procedures as well as competency of all team members to make the EHS process more robust and to institutionalize best practices.

The safety and health issues in construction industry need to be pay more attention due to the frequently development of high rise building in the country.

Many of the unpredictable hazards and accidents are available at the construction site and thousands of workers were injured and killed in every year.

The most common accidents at high-rise building construction site are workers fall from height and injuries caused by fallen object

This article is focused to identify the causes of accidents at high-rise building construction site and to identify the preventive measures for accidents at high-rise building construction site.

Besides that, this article will help in explaining the causes of accidents and identifying area where prevention action should be implemented, so that workers and top management will increase awareness

in preventing site accidents.

### **Safety while designing and construction:**

In India while designing the building, safety requirements pertaining to building construction and minimizing safety risk in designing stage of building is still not given desired focus.

There is also a myth that safety concerns will lead to greater cost and reduced productivity.

During a recent studies in other countries, it was found that:

- 60% of accidents studied could have been eliminated or reduced with more thought during design (European Foundation 1991)
- 50% of general contractors interviewed identified poor design features as affecting safety (Smallwood 1996)
- 47% of likelihood of reduction of 100 construction accidents studied, by design changes (Gibb et al 2004)
- 42% of 224 fatality incidents linked to design (1990-2003 in U.S.) (Behm 2004)
- 22% of 226 injury incidents linked to design (2000-2002 in OR, WA and CA)

In India although many laws and code of practices related to building design are in force but due to lack of stringent implementations many of the requirements are ignored while designing, the data related to faulty design of building is hardly available but Investigators and expert are pointing the cause of incident as faulty design, in some cases although they might have not caused the accidents, but proper design could have eliminated or minimized the risks and consequences of accidents while construction. This is not only attributed for whole building design but part thereto.

Apart from meeting all applicable codes requirements, factors to be addressed for safe design are:

- Realistic modelling
- Constructability
- Redundancy
- Design for maintenance
- Unusual and overlooked loading.
- Occupancy patterns
- Selection of safe materials.

## **Causes of accidents during High rise construction:**

Most accidents in high-rise building occur during the construction phase. That is because, in general, temporary structures and processes used in construction are more susceptible to failure than permanent structures themselves.

Approximately fifty percent of construction fatalities have been attributed, to falls from heights and fall through openings, Furthermore, Collapse of soil, failure of formwork and scaffolds, uses of defective equipments, tools and tackles, collapse of crane , improper guarding, hazardous chemicals , poor site lay out, run over through vehicle, improper ventilation , absence of lock out or tag out systems , improper roof works, unsafe structural erections and fire have a high risk of fatal accident, though fatalities occur across a wide range of construction activities.

Unsafe act is also a major contributing factor in accidents.

There are so many other reasons of causing the accident on high-rising building. Apart from the obvious reasons there are so many hidden reasons which can create a catastrophic incident.

Some of the hidden causes or contributory factors of accidents during constructions are:

- Lack of meticulous planning and periodical review on safety aspects.
- Engaging unskilled and untrained workforce.
- Unauthorized changes in sequence, materials, manpower, and equipments.
- Lack of training to working crew.
- Lack of risk perception and mitigation.
- Inadequate budgetary provision for safety expenses.
- Selection of contractors without considering their safety practices and safety performance.
- Lack of safety culture in constructing agency.
- Lack of Integration with other business process with EHS within project.
- Lack of adopting innovative or less dangerous practices.

## **Way forward to address the safety challenges and make workplace safer:**

As we scale up to accept new challenges in the fiercely competitive global arena, a high standard of safety will be a key differentiator. To take up the challenge, we have to make constant systematic and sustainable efforts to develop and strengthen SAFETY aspects in our design and operations.

For a sustainable business model, construction should be planned and carried out in a socially responsible manner, augmenting tenets of health and safety at various phases including engineering, procurement and execution.

A strong safety culture is a key element to attain global benchmarking of socially sustainable construction that can only be realized through collaborative efforts of all stakeholders including industry, academia, government and the public at large.

Identifying hazards and mitigating the risk prior to commencement of work is key for preventing accidents at construction sites, most effective way of addressing risks, are elimination of risk, substitution with less dangerous equipments or process and permanent reduction of risk by adopting engineering controls.

Managing safety well commences with leadership commitment and involvement to align the efforts to achieve international standards in Safety.

Construction business must proactively align with occupational safety and health standards in line with the good practices of global corporations in construction field.

It is important to adopt a structured approach towards the improvement of safety compliance through individual objective setting to inculcate the importance of safety in one's life. While such objective setting makes an individual more responsible and vigilant for his acts, it also demonstrates the management's commitment towards the safety and occupational health of its employees, and for the company at large. This has been successfully adopted through performance monitoring system for individuals by continuous review and linking with appraisal process to make every one accountable for safety requirements and related performance, tool used for this is safety app and automatic generation of safety performance score every month in L&T Construction for each individual and created a safety culture and sense of responsibility and accountability thus helped in accident prevention. This may be followed across construction business.

Over the years, several initiatives have been taken in L&T construction for safety cultural transformation, which may be instrumental in improving our collective commitment across construction business in India. We need to further strengthen these efforts to match with the global eco-system and establish our prominence in the international market.

As we proceed, we moved for adoption of innovative methods and application of advanced technologies like digitalization, artificial intelligence, Building Information Modelling (BIM), training through virtual reality (VR) kits etc.

L&T have successfully implemented complete digitalization of safety process to create a safe eco system and this has helped us in monitoring safety performance, inspections, compliances, safety assurance prior to start of work on day.

This invariably includes workmen repository, awareness through e-learning, app-based work permits and checklists, workmen tracking (restricted entry to unsafe zones) through RFIDs, online incident, near miss reporting, EHS suggestions and issuance of improvement slips reporting and real time feedback to top management.

It is imperative that during the initial engineering stage, the constructability and ease of installation is given paramount importance. Accordingly, the design needs to address modularization of work in order to increase groundwork, reduce work at heights and exposure to adverse weather conditions/environment.

As we move forward, implementation of BIM would help project visualization, hazard identification, efficient scheduling and improvement in safety. Soon, this will enable us to migrate from labourintensive to equipment intensive operations to reduce exposure of workers to hazards.

Workmen are key to the success of any project. Enhancement of their skill sets, job specific training and recognition will lead to more motivated workmen thereby creating a safer work environment.

A committed approach and the adoption of new technological solutions will help us to standardize processes, improve overall quality of the products and services rendered and thereby drastically reduce unsafe acts that result in Loss of Time and Cost.

Adoption of a 'zero tolerance' policy for safety violation is very important to effectively deal with these deviations and minimize recurrence. A structured approach towards 'consequence management' can play a pivotal role in this matter, establishing a culture of compliance.

Let us all take a resolve to adopt Safety as a core value, which is non-negotiable.

# ARCHITECTURAL TRENDS IN HIGH RISE OFFICE BUILDINGS

Ar. Nitin Gupta, Director

M/s Arcop Associates Private Limited

High-Rise buildings are the direct product of urbanization in the world. Compactness of a dense urban center leads to very high land price, which makes going vertical in the sky financially viable. Skyscrapers or High-Rise buildings were invented in New York and Chicago in early 20's.

Since then the structure design technology and the vertical transportation technology has progressed leaps and bounds and allowed architects not only to go higher and higher but also creatively mould these behemoths into urban sculptures.

It is interesting to note that while USA was the front runner in creating world record for highest building in the world till the third world became flag bearer for the desire to make the next highest building in the world. Malaysia, Taiwan and Dubai got into the Race and the crown that rest in Dubai in form of Burj Khalifa may remain in Middle East for a long time with Kingdom Tower in Saudi under construction and due to beat BurjKhalifa, when finished.



KINGDOM TOWER, SAUDI ARABIA



BURJ KHALIFA, DUBAI UAE



CUSTOMS OFFICE TOWER, WADALA, MUMBAI

Lee Kuan, the father of Singapore built skyscrapers in Singapore as a symbol of growth for his country. In recent years we have observed a very similar phenomenon in India.

The state chief ministers are vying for creating the most futuristic high rise building in the state capital as a symbol of progress in their state and attract investment. The central government ministries are implementing high rise towers in metropolitan cities like the Income Tax Tower at Bandra Kurla, Mumbai and proposed **Customs Office tower at Wadala, Mumbai** and **Police Headquarters, Delhi**.



POLICE HEADQUARTERS, HYDERABAD

The state of Andhra Pradesh got bifurcated and as a result state of Telangana was created. This set in a great healthy competition between the two state governments to create modern buildings in their state capitals.

Hyderabad, the capital of new state Telangana was already a well-established metropolis and Amravati, the new capital of Andhra Pradesh became the talk of the architectural offices around

the world.

Telangana created a grand vision inspired by Singapore to create a dozen of government high rise buildings. First in this vision was The Police Headquarters Tower at Banjara Hills. Government official brief to the architects was to create a new Icon for the city. The project is almost nearing completion and seems to be delivering the result as per the desire and brief of government.

It may be noteworthy to highlight the impact that some of the government high rise buildings in downtown Connaught Place in Delhi have created on the skyline of Delhi. The most impactful being the **LIC Building** by Ar.Charles Correa and STC building by Ar.Raj Rewal and **NDMC Tower** by Ar. Kuldeep Singh.



**NDMC TOWER, NEW DELHI**



**LIC BUILDING, NEW DELHI**



### **A BUILDING BY PRIVATE DEVELOPER**

The virtue of Government and rightly so is that as a system government has no need for greed and is not under any pressure to create real estate wealth out of its buildings. Hence the architect gets more freedom to design rather than become a mere FAR agent for builder. The Government is more responsible on issues of sustainability and environment and can take a longer term vision of utilizing energy saving technologies like solar roofs and facades.

Sequel to the Police headquarters in Hyderabad is the Iconic **Image Tower**. The ambitious ultra-modern high rise building envisioned by the IT Ministry of Telangana to house the Gaming and Animation Industry of Hyderabad

It may also be interesting to compare the timeless quality of architecture and the iconic nature of these buildings with rather insipid, characterless and drab commercial office glass towers created by the private developers around the country in the last two decades.



**IMAGE TOWER, HYDERABAD**

While the southern part of India was simmering and shining in its high-rise architecture as a result of Hyderabad vs Amravati competition, eastern India was experiencing stability in Assam after three decades of terrorism and political turmoil. The young CM of Assam desired to express this by creating vision to build the highest twin tower of India, so Hi-Tech and futuristic in its architecture that the state of Assam comes in direct competition with developed world of Far East and becomes a new gateway for

India in east. The Twin Tower today is called **World Trade Centre, Guwahati** and has established the building project as one of the key ten infrastructure projects happening in India.



**WORLD TRADE CENTRE, GUWAHATI**

The inference is that Government High Rise buildings shall be able carry the flag for creating iconic architecture for the Indian Cities and will continue to give architects the opportunity to explore new ideas and technology to keep pushing the skyscraper architecture in India.

# DIGITAL TELEPORTATION - ULTIMATE TRANSPORTATION IN & BEYOND HIGH RISE BUILDINGS

Er. C.K.Varma, CE CSQ (E), CPWD

## Abstract

As the buildings moved vertically under the pressure of population, vertical transportation has also assumed greater significance. Gone are the days when ladders were used for going up the roof. Permanent ladders in the name of stairs were then conceived, designed and built for upward, smooth and safe movement within the building. Later came the elevators which have revolutionised our thought process in upward movement within a building. But the journey has never stopped thereafter. There have been continuous improvements in a fast track mode in the way people are transported within a building particularly from one storey to another. This paper discusses the ultimate in the journey of vertical transportation system in buildings i.e. the teleportation or more precisely Digital Teleportation.

## Introduction

Teleportation contrary to transportation is basically transfer of matter or energy from one point to the other, without crossing the physical space between them. This concept was well depicted in a popular TV serial Startrek in the 90's wherein it was used in a spaceship that was traversing to the new frontiers.

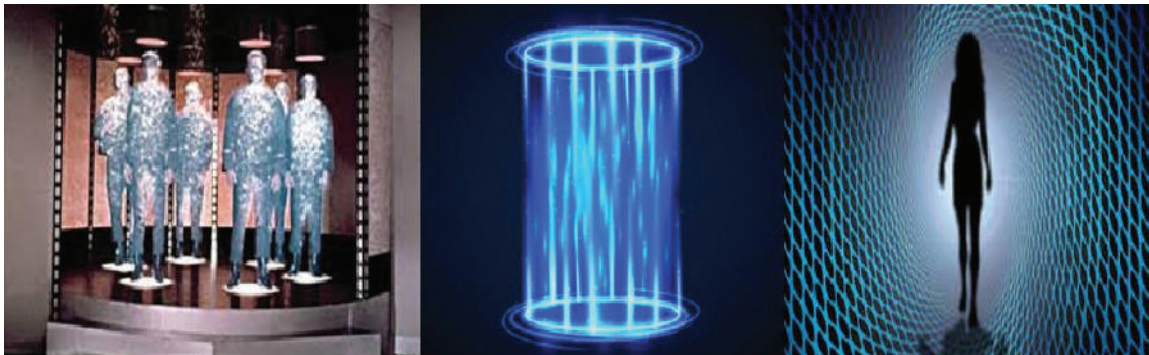

Figure 1: Teleportation depicted

Viewing that, it looked like that teleportation is only a matter of fiction and will never become reality. Nevertheless, consider that if teleportation becomes a reality; it will be a very fascinating technology which will make it possible for humans to travel vast distances without having to travel physically. It is not a secret now that a few enthusiast scientists have taken up this challenge and achieved partial success in developing the technology of teleportation.

## What is Teleportation?

The word Teleportation is the combination of Telecommunication and Transportation. As a concept, it looks amazing but impossible or at the most a very distant reality. However, scientists are working on this concept day and night and when it will turn into reality, it will be possible to get rid of unsafe and tedious physical transportation devices on one hand and travel will be instantaneous on the other hand. And when it will be possible, it will be like scanning human body down to the subatomic level and crushing all favourite parts at initial point and then sending all the scanned data to destination point, where a computer like machine will build up everything exactly ditto from nothing in a fraction of a second. However, there is one drawback in the entire process. It is that the original will be destroyed paving way for the scanned one to take over as original . Anyway, the original disrupted in the process will have to be discarded and everyone time “new you” will be born/emerge after teleportation.



**Figure 2: Teleportation Process Explained**

### The Work So Far

It is very difficult to believe this to happen. But then what we are seeing today in our life was also unbelievable a few years back. Thus, we have already travelled from the world of actual to virtual, from the world where machines were assisting us to the world where machines have taken over all important works from us. A few years back, it was impossible to believe that our office, bank, post office, theatre, music system etc. will be within our fingers. But science and technology has made that possible. So Teleportation should also not be seen with suspicion.

The hope is more than alive because scientists have achieved success in establishing quantum transportation which is nothing but one step forward towards the technology called teleportation. In quantum transportation, quantum information can be transported from one place to another by classical communication. Since it has been possible to transmit one or more qubits of information between two quanta, the concept of teleportation of humans is a possibility. The only limitation so far is that it has only been possible to do so at the quantum stage with the speed of light and only the molecules. However, scientists are combining the principles of Quantum transportation, Telecommunication and transportation for achieving breakthrough in this area of research.

The work is continuing today more vigorously than before as the researchers are combining different elements of telecommunications, transportation and quantum physics in amazing ways and the day is not far ahead when we will enter the era of digitalisation in the field of transportation as well.

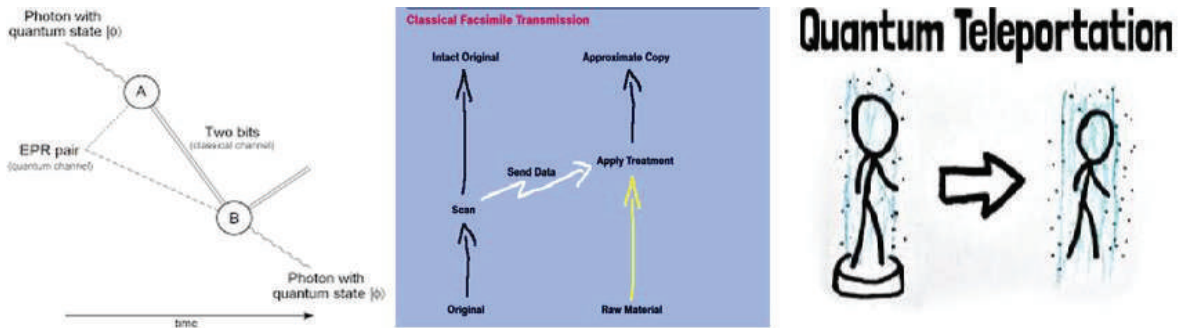
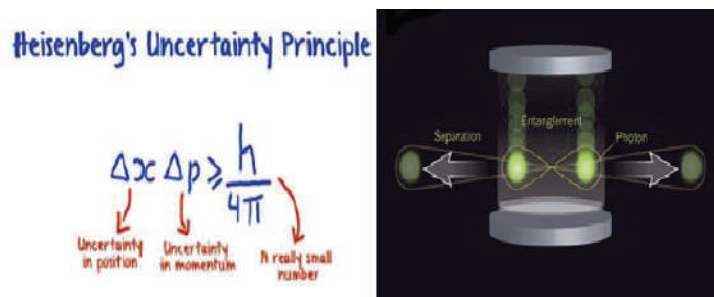

**Figure 3: Process of Quantum Teleportation**

### Experiments in Teleportation

The success story of teleportation began when in the year 1998, physicists at the California Institute of Technology (Caltech) & two European groups, successfully teleported a photon. Photon is nothing but the lightest known particle of energy that carries light. It was a great breakthrough towards making teleportation theory a reality. This team read the atomic structure of a photon and sent this data across 3.28 feet (about 1 meter) of coaxial cable and created a replica of the photon on the other side. As predicted, the original photon no longer existed once the replica appeared.

The Heisenberg Principle of uncertainty says that “location and momentum of a particle cannot be simultaneously known” was the main barrier and was skirted a little to carry out this experiment. This experiment further paved the way for particles bigger as well as larger than a photon. Thus knowing the position is essential for quantum teleportation. So phenomenon of entanglement in which three photons are used together was used to achieve the photon teleportation. But in the process, original photon ceased to exist before information sent to the third photon.

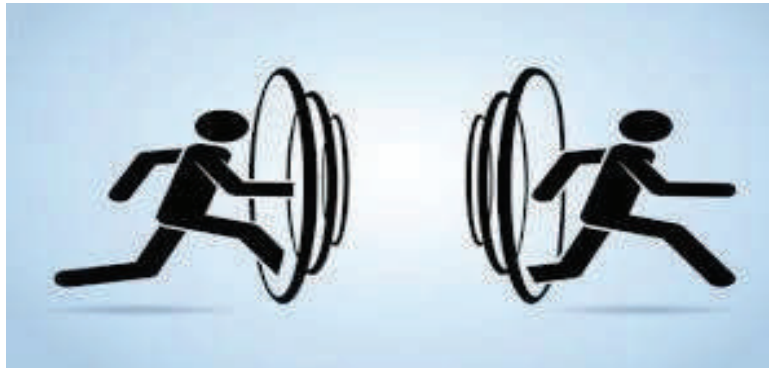

**Figure 3: Process of Quantum Teleportation**

Since then, scientists had worried a lot and could not make an impressive progress because of the dilemma to lose the original. However in 2002, researchers at the Australian National University successfully teleported a laser beam, and in 2006, a team at Denmark’s Niels Bohr Institute teleported information stored in a laser beam into a cloud of atoms about 1.6 feet (half a meter) away.

Further in 2012, researchers at the University of Science and Technology of China made a new teleportation record. They teleported a photon 60.3 miles (97 kilometres), 50.3 miles (81 kilometres) farther than the previous record [source: Slezak]. Just two years later, European physicists were able to teleport quantum information through an ordinary optical fibre used for telecommunications [source: Emerging Technology from the arXiv].

Given these advancements, quantum teleportation will affect the world of quantum computing and subsequently the teleportation. These experiments are important in developing networks that can distribute quantum information at transmission rates far faster than today's most powerful computers.



**Figure 5: Passing Through Teleportation Device**

### **Fears/Barriers attached to Teleportation**

Teleportation is one of those technologies which terrifies us more than it inspires. Certainly, travelling instantaneously from one part of the globe to the other or from Mother Earth to another planet in our solar system or any other solar system is an awesome power but at the risk of transforming our original particles. What if, our scanned version comes out

distorted due to some fault in the computer or power outage; we will remain so throughout our remaining life. Again if....., our teleported destination changes by mistake, we can never be at the designated place and where we will be again terrifies us. So technology has to find answer to all these fears and worries for our reassurance and faith in this technology of digitalisation of transportation.

Nevertheless, if a machine can digitize us and rebuild it on the other side of the planet, then why bother with a perfect copy? There are chances that the teleported copy could be far better in terms of youth, smartness and strength and we may be more happier than in earlier phase. Further, who knows that if one passes through the teleportor may emerge renewed with more vigour, virtues and more energy. Do we then call it as digital revolution in transportation which has both temptation and bad sides? However, if we ever achieve it, life, death, matter, space and time all will be mastered in one stroke.

### **Conclusion**

1. It is possible to achieve teleportation in the near future probably in this century itself which will revolutionise transportation ways, means and needs.

2. It may be possible to time travel, if this concept becomes real and one can meet his/her parents including forefathers who have died long back and meet the future generation also which will be ultraexciting.
3. Humans however will not remain their true/original selves but will turn into multiple scannedcopies.
4. The Highways, automobiles running on them at high speeds , carbon emissions from them, road rages etc. will be things ofpast.
5. Interplanetary travel will also become a reality and human mobility will be unimaginable.
6. All living beings including humans will reduce to data/information in real sense as their own transmission will beinstantaneous.

## **References**

<https://www.google.com/search?>

# RISK ASSESSMENT OF VERTICAL TRANSPORTATION SYSTEM IN HIGH RISE BUILDINGS

Er. C. K. Varma, CE CSQ (E), CPWD

## Abstract

Vertical Transportation System is an absolute necessity in High Rise Buildings for taking passengers within the building to their floor of choice. No high rise building today can be conceived without considering an appropriate vertical transportation system. Elevator is normally considered to be Vertical Transportation System in a High-Rise building. Elevator however is a general term while Lift is considered to be more specific while dealing with a high-rise building. Where numbers of floors are relatively higher, traction lift with high speed is the logical choice while for lesser number of floors, hydraulic lift with lower speed is also an option. But what considerations should be given while provisions are made for this system in a high rise building, is required to be assessed very carefully. This is because lifts are more prone to risk of human life and fire. This paper aims to highlight this and more from other considerations like quality, energy efficiency etc.

## Introduction

Risk assessment of providing Lifts in a High Rise building is very essential to understand the factors contributing to the dangers of human life because Lift is electro-mechanical equipment controlled by an electronic controller and moving inside a manmade structure made up of concrete and bricks. Further ,it remains in service for minimum 12X5 or 12X6 hours in an Institutional/Office building or 24X7 hours in a hospital / residential building. Moreover, during the entire working hours, the duty of the lift is quite stringent i.e. going up and down frequently as well as infrequently. The operation of the lift is also not done by professional persons always but by the users only who neither have expertise nor any kind of license. It has been seen that mostly ladies and children tend to operate the lifts in a residential tower. So the potential hazards of the lifts come to the fore when statistics pertaining to accidents of the lifts is seen and analyzed.

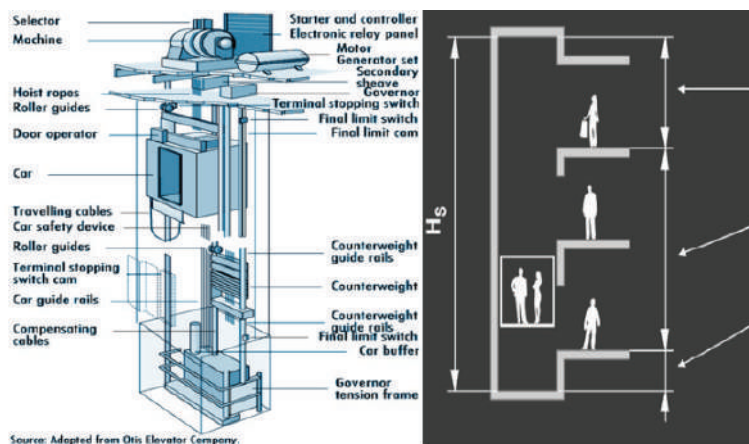

Figure 1: Scheme of Lift arrangement in a building including Various Parts of Lift

## **A Quick Way to Risk Perception**

A view of Newspaper Headlines of past will provide a quick method of Risk Perception. A few of these are given below:

1. Mumbai: Domestic help dies after leg gets caught in gap of elevator- The Times of India dated 22 Oct 2019.
2. Hyderabad: 9 year-old girl crushed to death in lift- The Times of India dated 19 Oct 2019.
3. Rajasthan: Kid crushed to death in temple lift- The Times of India dated 15 Oct 2019.
4. New Delhi: One dead, six hurt as wire of lift snaps at building site- The Times of India dated 06 Sep 2019.
5. Bengaluru : Four year-old boy crushed to death under lift -The Times of India dated 10 July 2019
6. Hyderabad: Mechanic dies in lift accident- The Times of India dated 30 May 2019.
7. Hyderabad: Elderly woman dies after fall in lift shaft- The Times of India dated 09 May 2019.
8. Hyderabad : Sweeper slips into lift shaft, crashes to death - The Times of India dated 20 Apr 2019.
9. Delhi: 4 workers die after tower crane lift collapses- The Times of India dated 29 Oct 2018.

The above headlines are the reported mishaps. There can be other accidents which might have gone unnoticed due to not being reported. A quick analysis of the above incidents, conclude that lifts is a high accident prone device despite many safety devices and processes built into the lift system. Thus issue of human safety becomes paramount in Lifts. Therefore most stringent safety standards should be followed.

## **Other Issues in Lift management**

There are other issues as well important in the performance of Lifts. These are:

1. Longer Down time of the Lifts- indicates a badly maintained lift which is an eyesore because up and down passengers always curse a standing lift.
2. Fire Rating of The Lift - Lift is very important in case of fire in a high rise building. In every Lift bank, at least one lift is designated as a Fire lift which in case of fire emergency is used by Firemen for reaching to the floor of fire and evacuation of trapped persons. Thus under extreme circumstances of fire, Lifts should not fail which is determined by the Fire Rating of the Lift Car.
3. Providing accessible environment- a well maintained and quality lift is very important to achieve this regulation of the Government. If most of the time lift will not function properly or will be down, the very purpose of providing accessible environment in a high rise building will be lost.
4. Passengers' comfort as well as ride quality – These are dependent on jerk and acceleration and are also very important parameters to be included in the Risk Analysis. Energy Efficiency is one more

point on which positive view is to be taken by all building owners.

5. Thus, all the above points should form part of the risk analysis and after doing proper evaluation and analysis, proper decision regarding quality, quantity, Safety, Reliability of Lift should be taken.

### **Steps in Risk Assessments**

Usually following steps are required in any risk assessment:

1. Identification of potential hazards based upon the past experience of experts and users.
2. The target group inhabiting the building
3. Assessment of various Risks including their probability of occurrence
4. Record making and Review.

### **Types of Risks in Lifts**

In case of Lifts, risks may be of following types:

1. Manufacturing Risks- Using Inferior Material, improper Quality Checks etc.
2. Installation Risks- Installation by inexperienced persons, No safety checks, No trial run of Lift for a sufficiently reasonable period etc.
3. Operational Risks- Occurrence of different types of faults due to multi-hand operations and wear and tear due to different operating conditions etc.
4. Maintenance Risks- Longer down time due to lesser availability of spare parts, trained staff etc.

### **Safeguards after Risk Assessment**

A good eligibility criterion for selection of Lift makers needs to be developed first, so that only quality brands should qualify in the bidding process. Following are the points worth considering for this purpose:

1. The Financial Turnover of the company during at least last three years. Some reasonable value should also be assigned to it so that applicant's financial standing can be judged.
2. The Net Worth of the company should also be asked with the condition that it should not be negative in any of the past years. This will be of significance particularly to evaluate that manufacturer is not facing any liability issue.
3. There should be a reasonable Manufacturing Experience specially spanning the entire estimated life of a lift. Normally, the life of a lift being electro-mechanical equipment is considered as 15-20 years. So a company should have these many years of experience of Lift Manufacturing, erection and satisfactorily maintaining them.
4. The Testing Facility is a must for testing various parameters of the Lift including speed, capacity,

safeties, Quality Standards etc. This indicates the seriousness of the Lift Manufacturer to carry on the Business for a longer Duration.

5. The Manufacturing Plant of the firm should also be modern and latest in order to avoid bad workmanship etc.
6. The firm should have trained staff and dedicated maintenance staff.
7. The downtime of Lifts in operation should not be more than 2-3 hrs in case of a minor faults and 7 days in case of major repairing.
8. The firm should guarantee availability of spare parts for the entire life period of the Lift.
9. Firm's capability to provide robust After Sales service. Since Lift is prone to frequent maintenance due to its stringent operational cycle , the firm should possess a strong network of maintenance personnel for repair and rescue operations.
10. Fire Rating of Lift car should also be specified as per Standards. Since Lift car has to work during Fire. So it should be able to withstand the high temperature generated by Fire during rescue operations.
11. Similarly there may be many other threats which should be properly analysed and incorporated in the eligibility criteria.

With this elaborate eligibility criteria in force, only quality manufacturers will be eligible to quote while ineligible ones shall be disqualified straightaway.

### **Barriers to Eligibility Criteria**

1. All new and ineligible manufacturers may make a big hue and cry regarding not being able to participate in the tendering process.
2. There can be court cases also on the ground of Natural Justice. But human life is more important and hence these cases should be defended vigorously.

### **A few interesting Facts about Lifts**

The storey of development of upward travel through machines is very interesting and dates back to 236 BC when the first lift was made and the credit for this goes to none other than Archimedes, a Eureka Man. It was reported by Roman architect Vitruvius and is the earliest known record of a lift. At that time, lifts were made from hemp rope and powered by animals or people.

Over the years, lifts improved as technology advanced. King Louis XV had one of the earliest elevators got designed for passenger use, known as the "flying chair." It was installed at Palace of Versailles in 1743 to allow mistress of King Louis to secretly visit him.

One of the big leaps in elevator technology came with the during industrial revolution while the first electric elevator was built by the German inventor Wener Von Siemens in 1880. Elisha Graves Otis (August 3, 1811 – April 8, 1861) an American industrialist has invented a safety device for preventing elevators from falling if the hoisting cable fails. He had founded OTIS Elevator Company which is a leading Lift

Brand worldwide.

Alexander Miles. Alexander Miles (May 18, 1838 – May 7, 1918) an **African-American** inventor was awarded a patent for automatically opening and closing **elevator** doors on October 11, 1887. This invention made elevators safer. In 1889, the first commercially successful electric elevator was installed. Joseph Giovanni, an American inventor, patented a safety bumper in 1944 that prevented the elevator doors from closing on a passenger or another obstacle.

Otis Elevators, now owned by Elisha Otis' sons, installed the first control system that automatically controlled the varying speed of elevators in 1924. The system automatically controlled the acceleration, speed between floors, and deceleration as the elevator came to a stop. Otis Elevators installed an elevator in the newly completed Empire State Building that was capable of traveling 1,200 feet per minute (366 meters per minute), according to Funding Universe Company Histories. The Empire State Building now contains 73 elevators. Otis Elevators introduced microprocessors into their elevator control systems, which they called Elevonic 101, in 1979, which made elevators fully automated,

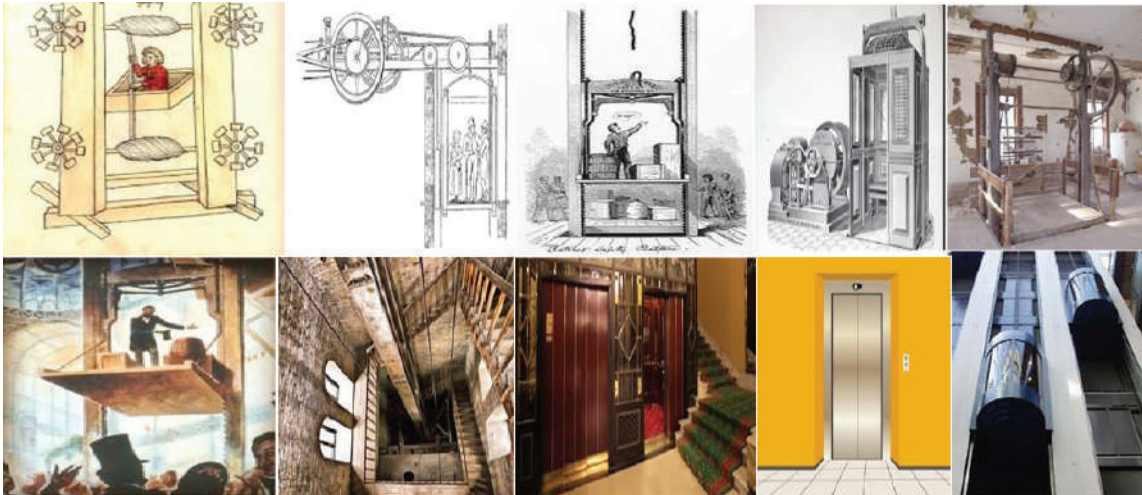

Figure 2 Progress in Elevators Technology

Schindler, Kone and Otis are ranked today as the major **elevator** and escalator manufacturers worldwide.

### Conclusion

1. Proper risk assessment is essential before going for call of tender elevator in a High Rise Building.
2. Robust eligibility criteria for selection of lift manufacturers is must in order to provide a cushion to the building owner and the building contractor for possible mishaps.
3. Transparent lift is also one of the options where any part requiring maintenance is visible to all and can be maintained in time.

### References

<https://www.google.com/search?>

# **SMOKE MANAGEMENT IN HIGH RISE BUILDINGS**

**Er. C S Mital**, Former Chief Engineer (Elect), CPWD

## **INTRODUCTION:**

Increasing Urbanisation, shift in employment opportunities from agriculture sector to industry or service sector and general growth in population has put stress on the availability of land in urban areas. This has necessitated construction of Multi storeyed buildings, be it for residential, office or Institutional use. At present we have thousands of high-rise buildings in India.

High rise or Multi story buildings provide good opportunity for showcasing creativity by Architects and Engineers alike. This has also resulted in a race amongst Modern Buildings to touch the sky. Each mega new building being constructed is planned to be higher than existing ones.

We all know the disastrous effects of fire. In spite of best materials use and good engineering practice happening of fire cannot be ruled out. Experience shows that in case of fire in high-rise buildings, much more people suffocate and die due to smoke as compared to casualties due to fire burn etc.

This paper discusses requirement of National Building code-2016 regarding Smoke Management in High-rise buildings and strategies to be adopted to comply those requirements.

## **1. High Rise Buildings:**

National Building code defines a high rise building as “A building 15 m or above in height (irrespective of its occupancy)”.

### **2.1 Height of the building is defined as follows:**

“The vertical distance measured in the case of flat roofs, from the average level of the ground around and contiguous to the building or as decided by the Authority to the Terrace of the last liveable floor of the building adjacent to the external wall; and in the case of pitched roofs, up to the point where the external surface of the outer wall intersects the finished surface of the sloping roof; and in the case of gables facing the road, the mid-point between the eaves level and the ridge. Where the building is located in a sloped terrain, height shall be determined from the lowest level (that is approachable by the fire service vehicles) to the terrace level. Architectural features serving no other function except that of decoration shall be excluded for the purpose of measuring heights.”

## 1. SMOKE:

**2. 3.1 What is Smoke:**Smoke is a collection of airborne particulates and gases emitted when a material burns or smolders, together with the quantity of air mixed into the mass. It is commonly an unwanted by-product of fires.

Smoke is an aerosol or mist of solid particles and liquid droplets that are close to the ideal range of sizes for scattering of visible light.

### 3.2 Effects of smoke:

Smoke scatters visible light and obstructs visibility of paths etc .This creates difficulty or delays in evacuation, which further compounds the effects of fire in a building.

The smoke kills by a combination of thermal damage, poisoning and pulmonary irritation caused by carbon monoxide, hydrogen cyanide and other combustion products.

### 3.3 How Smoke travels in High-Rise buildings:

Smoke propagation is affected by the building construction, air supply and smoke exhaust system. Smoke and toxic gases migrate outside the fire area to other areas in the structure and to Exposed areas.

**3.4 Smoke Management:**The whole strategy of Smoke management in a high-rise building revolves in control of smoke,its confinement to a limited area and spread to open atmosphere. Nowadays Most of the high-rise buildings are centrally airconditioned with fixed windows. In case of fire in such buildings smoke cannot vent and chances of suffocation of occupants increases. Smoke Management in Centrally AC high rise buildings need to be done with utmost care.

## 4 Smoke control:

### 4.1 Smoke control of Building Material

a) Surface Interior Finishes: The use of combustible surface finishes on walls (including facade of the building) and ceilings affects the safety of the occupants of a building. The finishing materials used for various surfaces and decor shall be such that it shall not generate toxic smoke/fumes.

b) IS 12777 :1989 Method for Classification of flame spread of materials may be made use of, while selecting various material for finishes. As per NBC-2016, Class-1 materials can be used in any situation, Class-2 materials may be used in any situation except walls, facade of building, staircase and corridor, Class-3 materials may be used only in living rooms and as lining to solid partitions, Class-4 materials shall be used with caution and in any case not to be used in kitchens, corridors and staircases. Panelling (lining) shall be permitted in a limited area, It shall not be permitted in a vestibule.

c) When frames, walls, partitions or floors are lined with combustible materials, the surfaces on both sides of the materials shall conform to the appropriate class, because there is considerable danger from fire starting and rapidly spreading within the concealed cavity unknown to the occupants whose escape may be hampered thereby.

d) Some materials contain bitumen and, in addition to risk from spread of fire, emit dense smoke on burning; such materials shall be excluded from use under these conditions and shall also not be used for construction of ceiling where the plenum is used for return air in air-conditioned buildings.

## 4.2 Smoke Control in Electrical Installation

a) wiring and cabling shall be with flame retardant property.

b) Medium and low voltage wiring running in shafts, and within false ceiling shall run in metal conduit.

c) The electric distribution cables/wiring shall be laid in a separate shaft. The shaft shall be sealed at every floor with fire stop materials having the same fire resistance as that of the floor. High, medium and low voltage wiring running in shaft and in false ceiling shall run in separate shaft/conduits.

d) use of bus ducts/solid rising mains instead of cables is preferred.

**4.3 Smoke Control in Battery Rooms:** Wherever batteries are provided, the same shall be segregated by 120 min fire rated construction. Ventilation to the room shall be provided as per manufacturer's instructions.

**Confinement and prevention of spread of Smoke in building:** Various methods to be adopted for confinement of smoke to affected area or preventing spread of smoke to other living area are discussed below:

### 5.1 Natural Ventilation:

a) As far as possible multi story buildings should be naturally ventilated so that in case of fire, smoke can be easily dispersed in atmosphere and occupants do not suffocate. It is always preferable to have Exit passage and Exits ( including Staircase, lift lobby etc) naturally ventilated. In case of naturally ventilated areas, there is no need to have mechanical smoke exhaust systems or Pressurization systems, because operation of such systems in real life situations remains a puzzle, in spite of best practices.

b) **Natural Ventilation of exit passageway** (from exit to exit discharge) shall be preferably naturally ventilated else it shall be pressurized. In case of natural ventilated staircase, openings/glazing in nearby walls shall be placed at least 3 Mtr away from windows of staircase.

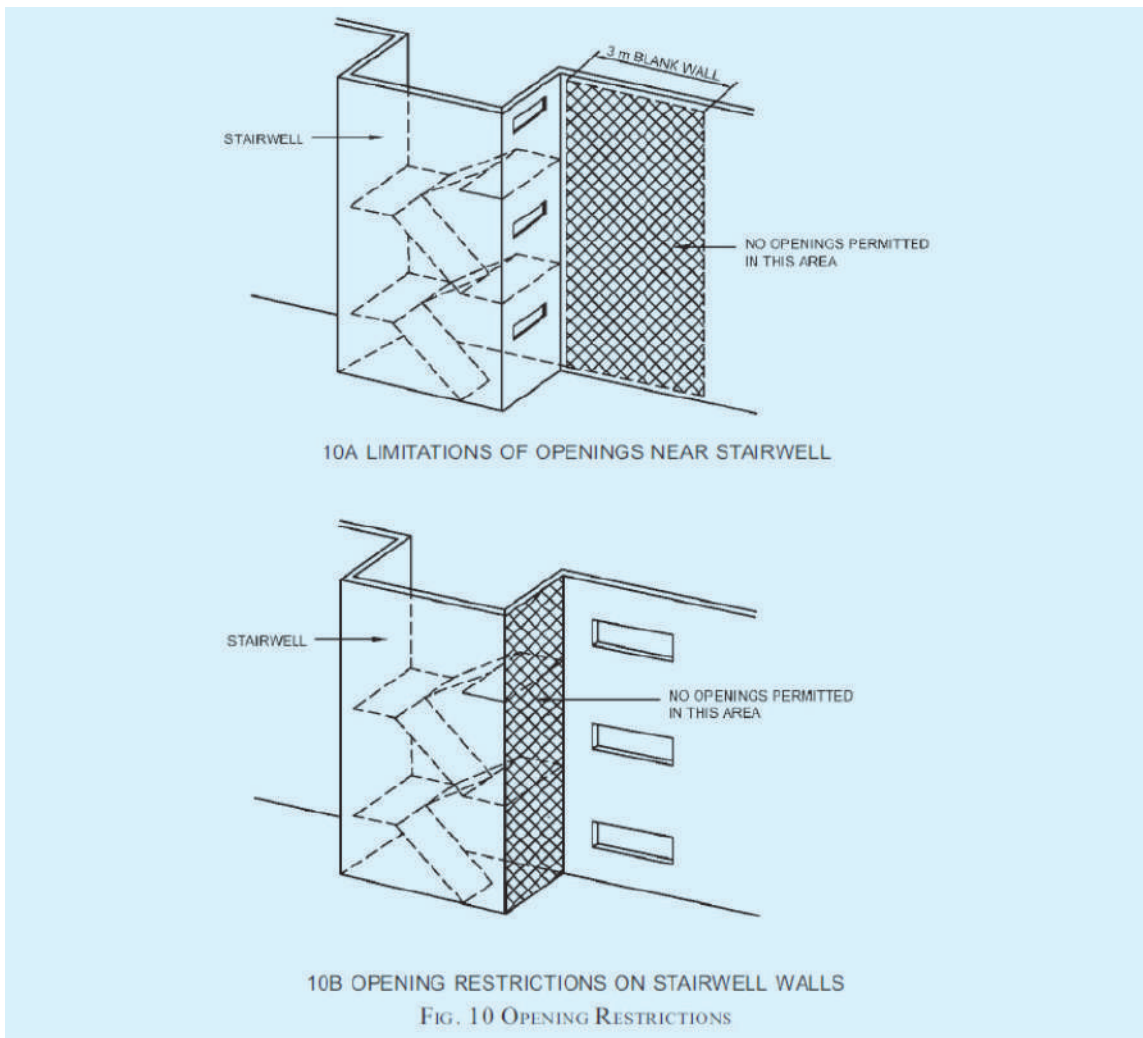

## 5.2 Basic requirements:

- a) Experience has shown that concealed spaces within a building, such as, space between ceiling and false ceiling, horizontal and vertical ducts and shafts, etc, tend to act as flues/tunnels during a fire. Provision should, therefore, be made to provide fire stopping within such spaces.
- b) For non-naturally ventilated areas, fire doors with 120 min fire resistance rating with shall be provided and particularly at the entrance to lift lobby and stair well where a funnel or flue effect may be created, to prevent spread of fire and smoke.
- c) Service ducts and shafts Openings in walls or floors which are necessary to be provided to allow passages of all building services like cables, electrical wirings, telephone cables, plumbing pipes, etc, shall be protected by enclosure in the form of ducts/shafts having a fire resistance not less than 120 min.

The space between the electrical cables/conduits and the walls/slabs shall be filled in by a fire stop material having fire resistance rating of not less than 120 min.

#### d) Refuse chutes

Refuse chutes, if any provided in a building, shall have opening at least 1 m above roof level for venting purpose and they shall have an enclosure wall of non-combustible material with fire resistance of not less than 120 min.

They shall not be located within the staircase enclosure or service shafts, or air conditioning shafts. Refuse chutes inspection panel and doors shall be tight fitting with 60 min fire resistance. Sprinkler protection system shall be provided for the refuse chutes. Refuse chutes shall be at least 6 m away from exits.

### 5.3 Compartmentation

**5.3.1 Purpose:** To limit the fire or smoke within affected compartment: Each fire compartment shall be separated to other fire compartment by fire rated barrier, so that in case of fire in one compartment, fire and smoke cannot travel to other compartment. Occupant of affected compartment are immediately evacuated to safer place.

5.3.2 All **floors shall be compartmented/zoned** with area of each compartment being not more than 750 m<sup>2</sup> in non-sprinkled buildings while the maximum size of the compartment shall be as follows in case of sprinklered basement/building:

#### Use of Area /Compartment Area m<sup>2</sup>

- i) Basement car parking 3 000
- ii) Basements (other than car parking) 2 000
- iii) Institutional buildings:
  - Subdivision C-1 1 800
  - Subdivision C-2 and C-3 1 125
- v) Mercantile and assembly buildings 2 000
- vi) Business buildings 3 000
- vii) All other buildings  
(Excluding low hazard and moderate hazard industrial buildings and storage buildings) 750

In addition, there shall be requirement of a minimum of two compartments if the floor plate size is equal or less than the areas mentioned above. However, such requirement of minimum two compartments shall not be required, if the floor plate is less than 750 m<sup>2</sup>.

4.3.3 In addition to floor compartmentation as above, in High rise buildings we shall have following additional compartments (as applicable):

- i) Each Staircase
- ii) Each Lift shafts
- iii) Each Lift lobbies
- iv) AC Plant room
- v) Substation
- vi) Electrical room
- vii) Pump room
- viii) Each Escalator Shaft
- ix) Atrium

5.3.4 Compartmentation shall be achieved by means of fire barrier ( wall or glass ) having fire resistance rating of 120 min. Compartmentation in basement is achieved by using a combination of wall and water curtain. Compartmentation for Escalator and Atrium is achieved by providing smoke barrier ( fire cloth curtain ) and sprinkles around the shaft at each level as shown below:

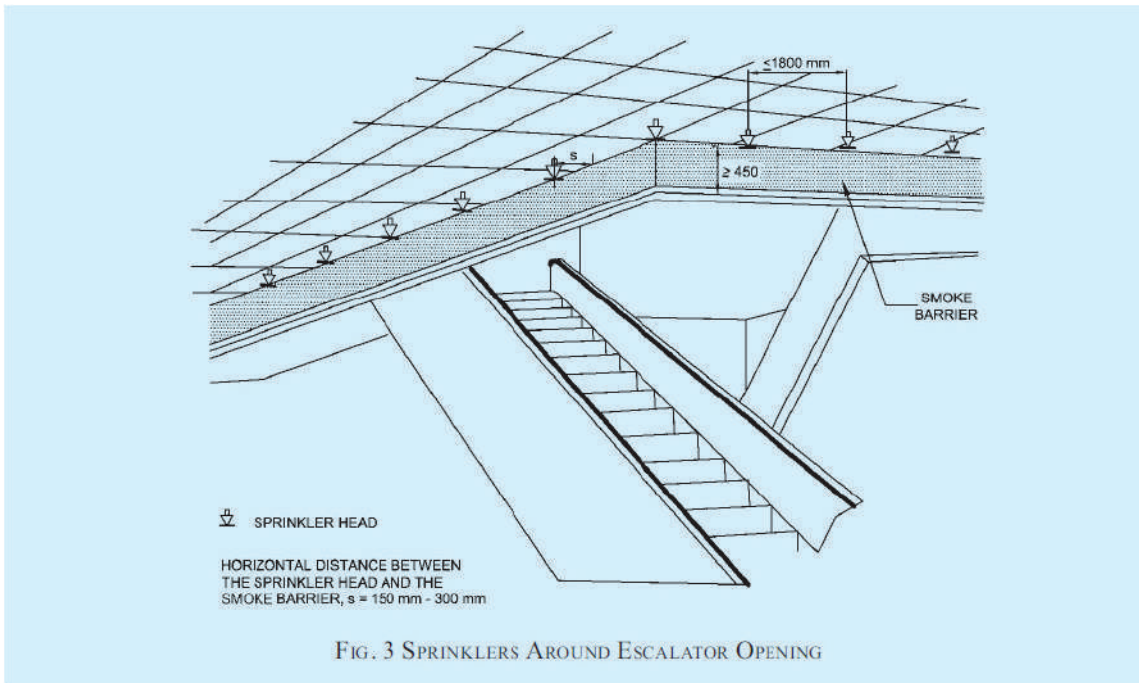

#### 5.4 Smoke Management through Ducts, Dampers and Air handling unit of Airconditioning

### 5.4.1 Duct work

- a) Air ducts serving main floor areas, corridors, etc, shall not pass through the exits/exit passageway/ exit enclosure. Exits and lift lobbies, etc, shall not be used as return air passage.
- b) As far as possible, metallic ducts shall be used even for the return air instead of space above the false ceiling.
- c) Wherever the ducts pass through fire walls or floors, the opening around the ducts shall be sealed compartment. Such duct shall also be provided with fire dampers at all fire walls and floors unless such ducts are required to perform for fire safety operation; and in such case fire damper may be avoided at fire wall and floor while integrity of the duct shall be maintained with 120 min fire resistance rating to allow the emergency operations for fire safety requirements.
- d) The materials used for insulating the duct system (inside or outside) shall be of non-combustible type. Any such insulating material shall not be wrapped or secured by any material of combustible nature.
- e) Exhaust air (or exhaust duct) shall not be collected (or pass) through annular space above false ceiling in Exit corridor or exit passageways.

**5.4.2 Fire/Smoke dampers:** Such dampers are provided so that these are either closed (if opened) or opened (if closed) automatically in case of fire to either prevent spread of smoke or for dissipating smoke to atmosphere.

Damper shall be of motorized type/fusible link. Damper shall be integrated with Fire Alarm Panel and shall be sequenced to operate as per requirement and have interlocking arrangement for fire safety of the building. Manual operation facilities for damper operation shall also be provided.

These dampers are located in supply air ducts, fresh air and return air ducts/passages at the following points:

- i) At the fire separation wall,
- ii) Where ducts/passages enter the vertical shaft,
- iii) Where the ducts pass through floors, and
- iv) At the inlet of supply air duct and the return air duct of each compartment on every floor.

### 5.4.3 Air Handling Unit

From fire safety point of view, separate air handling units (AHU) at each floor shall be provided so as to avoid the hazards arising from spread of fire and smoke through the air conditioning ducts. The air ducts shall be separate from each AHU to its floor and in no way shall interconnect with the duct of any other floor. Within a floor it would be desirable to have separate air handling unit provided for each compartment.

Air handling unit shall be provided with effective means for preventing circulation of smoke through the system in the case of a fire in the served AC area or at air filters or from other sources drawn into the system, and shall have smoke sensitive devices for actuation in accordance with the accepted standard and control.

## 5.6 Smoke Management of exits using Pressurization

a) In building design, **compartmentation** plays a vital part in limiting the spread of fire and smoke. The design should ensure avoidance of spread of smoke to adjacent spaces through the various leakage openings in the compartment enclosure, such as cracks, openings around pipes ducts, airflow grills and doors. In the absence of proper sealing of all these openings, smoke and toxic gases will obstruct the free movement of occupants of the building through the exits. Pressurization of staircases is of great importance for the exclusion of smoke and toxic gases from the protected exit.

b) **Pressurization Level** The pressure difference between the pressurized space and the adjoining area of the pressurized space, expressed in Pascal (Pa)

c) **Pressurization:** Pressure differentials between affected and unaffected areas help in confining smoke to area having lesser pressure. The establishment of a pressure difference across a barrier is used to protect exit, stairway, lobby, exit passageway or room of a building from ingress/penetration of smoke in high-rise buildings. In pressurization, air is injected into the staircases, lobbies, etc, as applicable, to raise their pressure slightly above the pressure in adjacent parts of the building. As a result, ingress of smoke or toxic gases into the exits will be prevented. The pressurization of staircases and lift lobbies shall be adopted as given in Table 6 of NBC. The pressure difference for staircases shall be 50 Pa. Pressure differences for lift lobbies (or corridors) shall be between 25 Pa and 30 Pa.

d) **When the emergency pressurization is brought into action**, the following changes in the normal air conditioning system shall be affected:

i) Any re-circulation of air shall be stopped and all exhaust air vented to atmosphere.

ii) Any air supply to the spaces/areas other than exits shall be stopped.

iii) Pressurization system shall be integrated and supervised with the automatic/manual fire alarm system for actuation.

iv) Wherever pressurized staircase or lift lobby is to be connected to unpressurized area, the two areas shall be segregated by 120 min fire resistant wall.

v) Fresh air intake for pressurization shall be away (at least 4 m) from any of the exhaust outlets/grille.

## 5.7 Smoke Exhaust of Areas Above Ground

In normal high-rise buildings, Smoke exhaust system having make-up air and exhaust air system or alternatively pressurization system with supply air system for exit access corridors shall be required. This would enable easy exit of people through smoke-controlled area to exit discharge

Smoke exhaust system having make-up air and exhaust air system (12 air changes) shall be required for theatres/auditoria, Large lobbies, Conference rooms etc. Exit access corridors of Hotels, guest rooms and indoor patient department/areas having patients lacking self-preservation and for sleeping accommodations such as apartments, custodial, penal and mental institutions, etc shall also be provided similar systems.

The mechanical Smoke Exhaust system or pressurization system shall be automatic in action with manual controls in addition. All such exit passageway shall be maintained with integrity for safe means of egress and evacuation. Doors provided in such exit passageway shall be fire rated doors of 120 min rating. The smoke exhaust fans in the mechanical ventilation system shall be fire rated, that is, 250°C for 120 min.

For naturally cross-ventilated corridors or corridors with operable windows, such smoke exhaust system or pressurization system will not be required.

### **5.8 Smoke Exhaust of Areas Below Ground:**

**5.8.1 Natural Ventilation:** Vents with cross-sectional area (aggregate) not less than 2.5 percent of the floor area spread evenly round the perimeter of the basement shall be provided in the form of grills, or breakable stall board lights or pavement lights or by way of shafts.

**5.8.2 Mechanical Ventilation/Smoke Exhaust System:** If natural ventilation can not be provided, mechanical ventilation system having minimum 12 air changes per hour in case of fire or distress call and 6-8 air changes in normal mode needs to be provided. In case of Sewage treatment plant no of r changes required is 30.

#### **5.8.2 Requirements for Smoke Exhaust of Areas Below Ground:**

a) In multi-level basements, independent air intake and smoke exhaust shafts (masonry or reinforced concrete) for respective basement levels and compartments therein shall be planned with its make-up air and exhaust air fans located on the respective level and in the respective compartment.

b) Due consideration shall be taken for ensuring proper drainage of such shafts to avoid insanitation condition.

c) Inlets and extracts may be terminated at ground level with stall board or pavement lights as before. Stall board and pavement lights should be in positions easily accessible to the fire brigade and clearly marked AIR INLET or SMOKE OUTLET with an indication of area served at or near the opening.

d) Smoke from any fire in the basement shall not obstruct any exit serving the ground and upper floors of the building.

e) The smoke exhaust fans in the mechanical ventilation system of basement shall be fire rated, that is, 250°C for 120 min.

- f) The smoke ventilation of the basement car parking areas shall be through provision of supply and exhaust air ducts duly installed with its supports and connected to supply air and exhaust fans. Supply air grills shall be installed at foot level ,while exhaust grills at higher levels.
- g) Power supply panels for the fans shall be located in fire safe zone to ensure continuity of power supply.
- h) Power supply cabling shall meet circuit integrity requirement in accordance with accepted standard .
- i) The smoke extraction system shall operate on actuation of flow switch actuation of sprinkler system. In addition, a local and/or remote .manual start-stop control/switch shall be provided for operations by the fire fighters.Visual indication of the operation status of the fans shall also be provided with the remote control.
- j) No system relating to smoke ventilation shall be allowed to interface or cross the transformer area, electrical switchboard, electrical rooms or exits.
- k) Smoke exhaust system having make-up air and exhaust air system for areas other than car parking shall be required for common areas and exit access corridor in basements/underground structures and shall be completely separate and independent of car parking areas.
- l) Smoke exhaust system having make-up air and exhaust air system for Sub Station/ AC Plant Room/ Pump room or other mechanical areas shall be separate.
- m) Supply air grill shall not be less than 5 m from any exhaust discharge openings.
- n) Outside air intakes shall be located at least 8 m away from exhaust stacks, toilet shafts, cooling tower and/or any other polluting source.
- o) Exhaust outlets shall be located at a minimum height of 3 m away from ground level and away from doors, occupied areas and operable windows. Locating exhaust outlets above the roof, projecting upwards, is preferred.

### **5.9 Smoke Management: Glazing**

- a) All gapsbetween floor-slabs and façade assembly shall be sealed at all levels by approved fire-resistant sealant material of equal fire rating as that of floor slab to prevent fire and smoke propagation from one floor to another.
- b) Openable panels shall be provided on each floor and shall be spaced not more than 10 m apart measured along the external wall from centre-to-centre of the access openings. Such openings shall be operable at a height between1.2 m and 1.5 m from the floor, and shall be in of size not less than 1 000 mm × 1 000 mm opening outwards. The wordings .FIRE OPENABLE PANEL : OPEN IN CASE OF FIRE, DO NOT OBSTRUCT. of at least 25 mm letter height shall be marked on the internal side. Such panels shall be suitably distributed on each floor based on occupant concentration. These shall not be limited to cubicle areas and shall be also located in common areas/corridors to facilitate access by the

building occupants and fire personnel for smoke exhaust in times of distress.

### **5.10 Providing Guidance for Exit in case of smoke, using Exit signage**

a) Where there is a smoke, visibility becomes very low. In such case exit Signage is a great boon for occupants to follow desired path for evacuation. Following signages the occupants should be able to easily identify the way to exits. Size and Color scheme of Exit signs shall be provided as per IS :9457:2005.

b) Exits shall be clearly visible and the route to reach exit shall be clearly marked and signs posted to guide the occupants of the floor concerned. An exit sign indicating the direction to an exit shall be provided at all changes in direction. Signs shall be illuminated and wired to an independent electrical circuit on an alternative source of supply. The exit sign with arrow indicating the way to the escape route shall be provided at a suitable height from the floor level on the wall and shall be illuminated by electric light connected to corridor circuits. All exit way marking signs should be so installed that no mechanical damage shall occur to them due to moving of furniture or other heavy equipment.

c) No point in an exit access should be more than 30 m from a visible exit directional sign. Further, all landings of floor shall have floor indicating boards prominently indicating the number of the floor.

d) Photo luminescent markings shall be pasted at internal hydrant boxes.

### **6. Conclusion:**

Fire in any building cannot be ruled out. Building planner has to consider the worst scenario of smoke and fire in such buildings. Efforts of Architects and Engineers should be to use materials causing minimum and least poisonous smoke. High-rise buildings should be planned and maintained for safe and economical Life and fire safety arrangement. Safety of occupants in distress of any kind should take precedence over any fancy idea/feature in any high-rise building. No one should lose life due to Architects or Engineers who designed, constructed or are maintaining such buildings.

# FIRE SAFETY AND BUILDING SERVICES IN HIGH RISE BUILDINGS

Er. Sandeep Goel, Director, M/s Proion Consultants Pvt. Ltd., New Delhi

High-rise buildings have an iconic and exceptional liking world over as they provide a unique challenge to the design fraternity to meet the objectives of occupant safety, building resilience in construction and an approach to design and plan MEP Services.

As per National Building Code define High-rise building as “**A building 15 m or above in height (irrespective of its occupancy)**”.

As per NFPA a High-rise is defined as “**A building where the floor of an occupiable story is greater than 75 ft (23 m) above the lowest level of fire department vehicle access**”.

However, in true sense high rises are more detailed explained and categorized by their Heights by Council of Tall Building and Urban Habitat (Chicago) USA as Tall, Supertall and Megatall.

## Supertall and Megatall Buildings

Tall buildings that achieve significant heights are classed in two additional sub-groups: A “supertall” is a tall building 300 meters (984 feet) or taller, and a “megatall” is a tall building 600 meters (1,968 feet) or taller. As of today, there are 149 supertalls and only 3 megatalls completed globally.

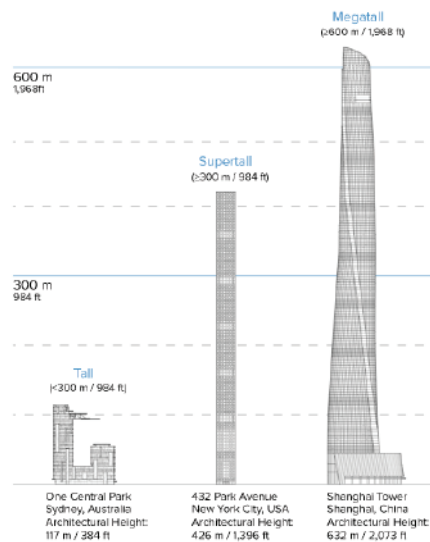

AS per CTBUH, Although number of floors is a poor indicator of defining a tall building due to the changing floor to floor height between differing buildings and functions (e.g., office versus residential usage), a building of 14 or more stories – or more than 50 meters (165 feet) in height – could typically be used as a threshold for a “tall building.”

In design of fire safety and building services of the Projects and Buildings in most cases, the challenges are to be holistically planned for Projects and Buildings over 100 meters of height since beyond this height these buildings pose several unique challenges not found in traditional low-rise buildings; longer egress times and distance, evacuation strategies, fire department accessibility, smoke movement and fire control while on Building Services the aspect of Electrical Services distribution, Water Supply Zoning, Conveyance of Soil and Waste and most importantly the design and planning of vertical transportation such as elevators which are also put to use for assisted evacuation. On the HVAC Systems, the hydraulic pressure zoning by use of Heat Exchangers and the placement of High Side Equipment

are also to be considered for energy efficiency in distribution.

Towards Occupant safety, the multiple floors of a high-rise building requiring occupants on the high-rise floor to travel great vertical distances on stairs in order to evacuate the building.

On the construction aspect, high-rise buildings construction is characterized by high demand of construction technology and complex engineering works.

NFPA Research paper (2016) on High-Rise Building states:

*Five property use groups account for almost three-quarters (73%) of high-rise fires:*

1. Apartments or other multi-family housing (62% of all high-rise fires)
2. Hotels (4% of high-rise fires)
3. Dormitories (4% of high-rise fires)
4. Offices (2% of high-rise fires)
5. Facilities that care for the sick (2% of high-rise fires)

Design Codes such as IBC, IFC, NFPA, CIBSE are used to ascertain the approach on the design and planning of high-rise building fire safety and building services.

Importantly, the National Building Code of India and the referred BIS Codes do provide an updated and modern approach on the design and planning of high-rise buildings fire safety and building services.

The approach of this paper is to highlight the aspect of Fire Safety and Building Services design.

**On Fire Safety, the key aspects of consideration are:**

#### **Fire Alarm System:**

The selection, design and planning of Fire Alarm is considered the most important since at the outset it can raise alarm, generate evacuation messages and align the functioning of the electromechanical systems which are so very important for the safety of the occupants.

All efficient egress design will not be significant if the Occupant are not warned or alarmed of an incident and given the directions to proceed to exit.

Fire Alarm System include (Manually Operated Fire Alarm System, Public Address System, Talkback System).

Photoelectric alarms are more responsive to smoldering fires whereas ionization detectors are better for flaming fires. Photoelectric tend to be more commonly used in residential occupancies, as they are quick to detect smoke coming from burning fabrics and furnishings.

Due to the varied nature of environments in commercial projects, there are many different types and

combination of fire alarm systems to fulfil specific fire safety requirements. These include wireless or radio fire alarms, VESDA and voice alarms with built-in public address systems.

Depending on the occupancy, Manually Operated Electronic Fire Alarm System (M.O.E.F.A) or Automatic Operated System (A.F.A) shall be provided in the building.

Also, in the same essential aspect of provision, is one of the most ignored and not efficiently designed - Egress Signage, its power back up and Emergency Lighting System. All these systems are required to enable the Occupant to proceed to exit in case of fire and smoke scenarios in the areas of building-occupancy.

**Means of Egress:**

The design and planning of Safe Means of Egress require collaborative working of Architects and MEP Engineers to keep the spaces with ease of access and control the smoke ingress in the identified, enclosed and demarcated areas which are in specific classified as Exits and Exit Passageway.

The term means of egress relates to a continuous way of travel from any point in a building or structure to a public way consisting of three separate and distinct parts:

- (1) the exit access
- (2) the exit
- (3) the exit discharge

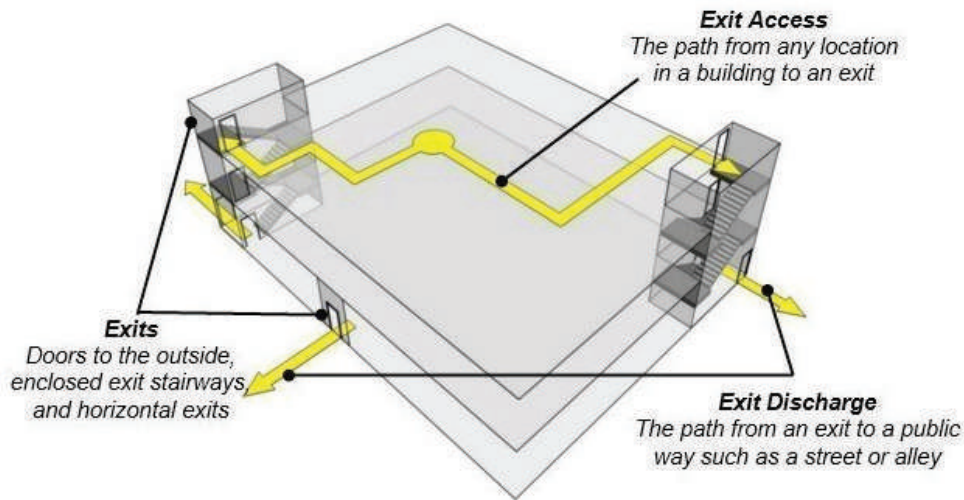

Separation of the means of egress from other use areas is important to ensure a route of safe passage for the occupants. Occupants from the zone of fire origin may be moved to another area of the building that is protected from the fire zone. Phased evacuation is often associated with high-rise buildings. For Evacuation through Protected routes Exit signages, Fire Rated doors, Hold Open devices, Emergency lighting etc., are used.

## Fire Tower:

The NBC 2016 introduced the aspect of Fire Tower in High rise buildings. It can be difficult for the fire and rescue service to safely reach and work close to fires, under such circumstances additional facilities are required to ensure that there is no delay and to provide a secure operating base.

Fire Tower includes a Fireman lift, Staircase, Fireman Talkback and Wet riser with Hose reel.

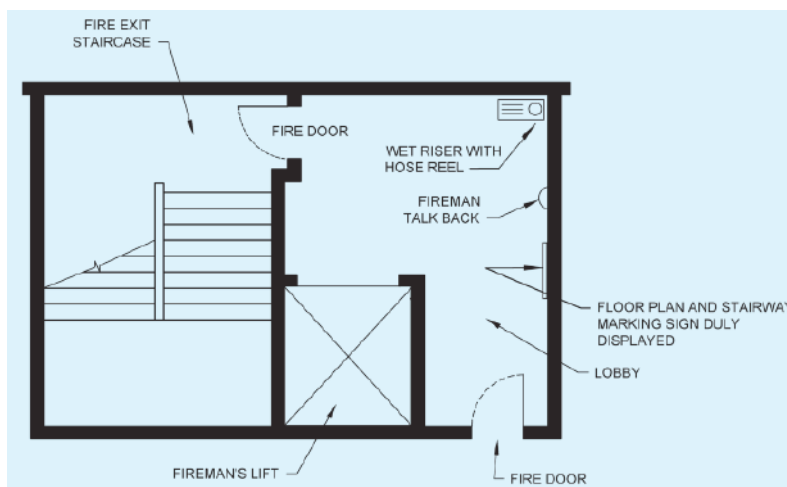

As per NBC all buildings higher than 15 m required to have Fire Tower.

## Refuge area:

An area within the building for temporary use during egress. It generally serves as a staging area which is protected from the effect of fire and smoke.

A 2-way Talkback system is provided in each area of refuge, through which call to Fire Command Centre in case of fire.

As per NBC, Part 4, Refuge area in residential building is required in building height more than 60 m. It shall be provided above 60 m and thereafter at every 30 m.

In Business building refuge area is required for height more than 24 m. It shall be provided immediately above 24m and thereafter at every 15m.

## Automatic Suppression system:

An automatic sprinkler system is designed to detect a fire and extinguish it with water/any other extinguishing agent in its early stages or hold the fire in a compartment and not allow to spread in the building.

Many types of Sprinkler System are present such as

1. Wet Pipe Fire Sprinkler Systems
2. Dry Pipe Fire Sprinkler Systems
3. Foam Fire Sprinkler Systems

#### 4. Pre-action Fire Sprinkler Systems

#### 5. Deluge Fire Sprinkler Systems

Each system is used in different situations for example Dry pipe sprinkler system is used where ambient temperature is every low hence pipe can have tendency to freeze.

#### **Smoke Extraction System:**

In case of fire in a building, whether a residential or commercial it is necessary to extract the smoke from fire zone in order to evacuate people and possible victims, to protect the building structure and facilitate fire-fighter access. It helps to improve the visibility of occupant, reduce the temperature to soar and supply fresh air dilute toxicity of atmosphere.

This system is installed in Exits, Lift Lobby, Exit Passageway, Identified Corridors, basement car parking and common areas of access to exits in Basements.

Smoke Exhaust system consist of extraction fans, Fire damper, fire rated ductwork etc.

#### **On Building Services, the key aspects of consideration are:**

##### **Electrical Services:**

Electrical supply and distribution in any building is an essential service enabling functioning of the important aspects of lighting, water supply, comfort conditions, air flow, ventilation, aspect of air conditioning, heating, vertical transportation and other services in the building.

Requirement of electrical power in a building/ complex increases over the time span of the building with ever increasing requirements of ancillary services and it is prudent to have the electrical supply and distribution services well designed considering future expansion, flexibility, scalability and most importantly, professional and well organized electrical installation ensuring owners/ users' understanding and propose use of installation without burdening the system beyond the proposed requirements.

While in most cases, the cause (or initiation) of fire is attributed to electrical installation which may or may not be correct in consideration, it is a known fact that fire initiated due to any reason will involve the electrical installation and can result in failed functioning of the life safety services, which are so crucial towards requirement of life safety aspects of evacuation annunciation, creating of compartments, pressurization and ventilation of exits, vertical transportation and importantly, fire protection services.

In high rise buildings, electrical distribution is to be efficient and safe.

For buildings where dry type substations are installed/provided at upper floor, the base substation shall be in such a way to provide direct access to the firemen in case of any emergency. The power supply control to any substation or transformer located at upper floors shall be from the base substation so that in case of fire, the electrical supply can be easily disconnected to avoid additional losses. The power supply HV cables voltage shall not be more than 12 kV and a separate dedicated and fire compartmented shaft should be provided for carrying such high voltage cables to upper floors in a building.

##### **Water Supply and Soil/ Waste + Vent Piping:**

The design of efficient and reliable plumbing systems in high-rise structures requires careful awareness

of water pressure issues, water access logistics, hot water system efficiency, drainage problems, vent stack problems. On aspect of height the building, understanding the constraints imposed by gravity, and being aware of established plumbing design principles, the design engineer can avoid the challenges that these systems can pose.

Therefore, in any high rise building the most essential aspect of design and planning is on zoning system.

In water supply, most of the codes would require number of floors on the zone to be 8 to 10 while the equivalence in cold an dot water supply is essential to meet the user safety. A well zoned system avoids surges and exceeding permissible pressures while also helps in energy saving in pumping and distribution.

Pressure control on the drainage side presents other challenges. True, water is essentially the same in either system; however, drainage theory holds that considerable air travels downward with the water flow. This theory asserts that water flowing in a vertical pipe tends to adhere to the pipe's walls, acting very much like a sleeve of water with a hollow core of air, all sliding down the pipe's walls until it reaches a ratio of approximately 6/24 full of the pipe cross-sectional area.

This watery sleeve travels at almost 15 feet per second (fps), propelled by gravity but restricted by friction. When the piping remains vertical, the entrained air is relatively simple to control, but when piping offsets from the vertical, the fluid flow velocity drops considerably, filling the entire pipe diameter. Horizontal, sloped drainage piping should flow in the 4–8 fps range, so it is easy to see that a large slug of water can quickly develop. This can lead to compressing air in the path of the fluid and/or lowering air pressure on the leaving side of the fluid flow. The impact of these fluid and air fluctuations can be controlled by effective use of yoke vents, relief vents, and vent connections at the bases of stacks. Here again, the solutions are largely not unique and have been used successfully on many intermediate-height and even extremely tall high-rise buildings.

A related concern is the impact of the hydraulic jump on the piping itself. The mass of water and the rapid change of velocity from vertical to horizontal cause this jump. While the pressure associated with this jump is significant, it does not destroy the fitting at the base of the stack. Rather, the movement of the pipe stresses the frictional forces that hold the joint to the pipe, leading to eventual coupling failure.

### **Conclusion:**

A systematic and well-planned approach aligned to the Codes would be required in the design and planning of Fire Safety and Building Services for a high-rise building. There are essentially aligned requirements of lighting protection system, efficient solid waste handling, sustainability goals and aspects, rain water storage and façade integration leading to overall high efficiency criteria being met with EPI (Energy Performance Index) benchmarking and also meeting the safety requirements for the Occupants.

This requires a collaborative approach by Stakeholder and close working between Architectural and MEP Design Team.

The topic is vast, but the vision is infinite.

# **REQUIREMENTS FOR HIGH RISE BUILDINGS-**

## **CASE STUDIES OF IIT BOMBAY PROJECTS**

**Er. P. C. Mathur**, CE cum ED, CPWD, Mumbai

**Er. Saransh Kataria**, EE & SM, CPWD, Mumbai

### **Abstract**

Indian cities are witnessing immense demographic expansion due to migration from surrounding villages, leading to urban sprawl, housing demand, rise in cost of land. Housing has developed into an economy generating industry. Given this demand, while high-rise residential structures have become a solution in the metropolitan cities but they have their own challenges in planning, designing and execution. The paper presents the case studies of the design features of the Research Park building(G +14 storeys) & Faculty accommodation( Residential Building B-25 with Stilt/Ground + 20 storeys) being executed by CPWD for IIT Bombay.

### **INTRODUCTION**

Tall buildings throughout the world are becoming popular day by day. With the advent of modern day construction technology and computers, the basic aim has been to construct safer buildings keeping in view the overall economics of the project. A high-rise building, apartment tower, office tower, apartment block, or block of flats, is a tall building or structure used as residential and or office use to decongest the urban sprawl on the ground level, and increase the urban density, housing higher number of families in lesser space. Benefits include they act as landmarks; create unique skyline and efficient land use.

A building is considered to be as high rise when it extends higher than the maximum reach available to fire fighters. When this happens fire is fought by personnel from inside the building rather than from outside. From the structural point of view it can be defined as a building where height will be affected by lateral forces resulting from earthquakes and wind forces to an extent that such forces will play a major role in the process of design.

### **WHY HIGH RISE BUILDINGS ARE REQUIRED**

**The main reasons to build tall can be summarized as:**

- Economic gain in areas with high land prices
- Building a denser city
- Publicity
- Fascination

## CASE STUDY- RESEARCH PARK BUILDING AT IIT BOMBAY



The Research Park Building is being constructed on triangular plot of area approximately 9500 square meters. It is proposed for G+14 with total height 69.9meters. Broad scope of work assigned to CPWD is to construct the RCC structure along with E&M services & finishing of common areas & Research Park office. The internal area i.e. units will be leased out to the industries & companies for R&D work and the finishing of the units shall be carried out by them as per their specific requirement. The building has been designed for GRIHA rating of 3 stars.

**The salient features and design details are as below:**

Architectural Design Parameters:

### 1. Orientation

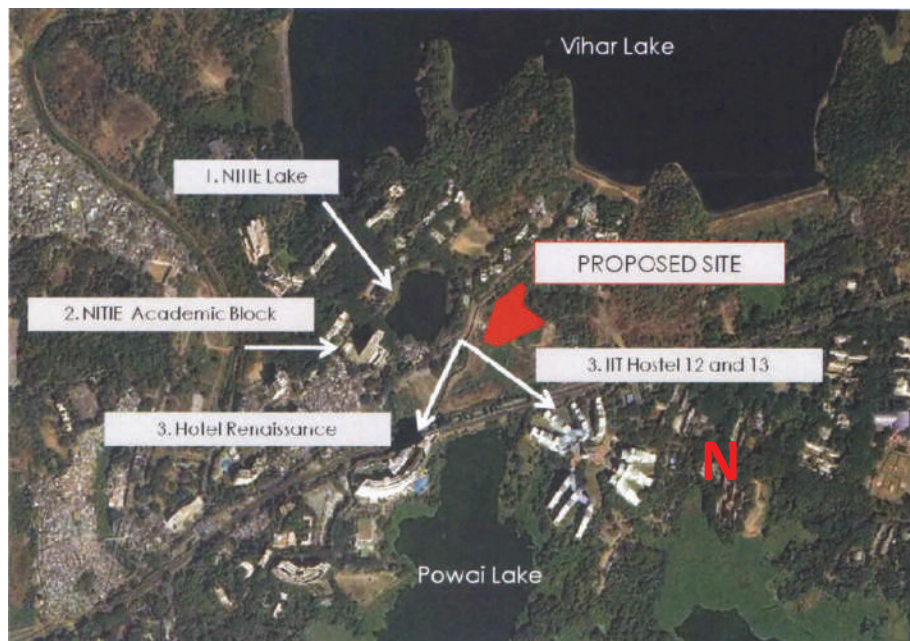

The building is located while taking advantage of maximum north light and south-west breeze, while minimizing effect of harsh light and heat on the south side. There are three lakes in the immediate

diate vicinity of the site, the NITIE Lake, the Powai Lake and the Vihar Lake. The design utilizes maximum scenic views towards the North, South and West. The elevation of the site is approximately between 61M to 64M above mean sea level and has gradual contours.

## **2. Lighting**

General lighting has been designed to create comfortable ambient light as 200-300 lux to suit the user requirements considering the recommended Luminous flux levels higher than the average in the institutional building. Controls and sensors will be used to conserve energy. The building has been designed to maximize the use of daylight. Light shafts provision is proposed in the concept design that will open the building to its surroundings. Sculpting of the building will help in directing light to the interiors of the building. Design of the façade, shading etc. helps in optimizing the light entering the building.

## **3. Air Conditioned ventilation**

VRV (Variable Refrigerant Volume) system is proposed for the building. This will assist in better control the usage of the conditioned air, thus conserving energy and creating an efficient life cycle. Typically temperature in Mumbai varies between 20°C and 33°C, with annual average relative humidity recorded as 74%. This is considered while designing the air conditioning system.

## **4 Natural ventilation**

Approximately 50% of the total carpet area of the building is naturally ventilated. Massing of the buildings designed to enhance natural ventilation in the building. Buffer zones on outer side of the building, will be a plus for naturally ventilating these spaces. Mumbai has a moderate climate. Additionally, proximity to the Powai Lake and surrounding tree cover has created a very comfortable micro-climate at the site. Hence, natural ventilation of the building is favorable. Displaced ventilation improves natural ventilation.

## **5. Heat**

Typically temperature in Mumbai varies between 20°C and 33°C. Hence, heating of the building is not needed. Insulation to heat is necessary. This will be done by buffer zones, shading, materials and other design tactics. Window openings help in dissipating heat from the building. DGUs (Double glazed Unit) with high reflectivity will be used for glazing to reduce heat gain.

## **6. Water**

Total water demand has been assessed as 1,89,000 LPD. Underground water storage of 4,00,000 liters (including fire tank of 2,00,000 liters capacity) has been planned for the building. Storm water management will be based on GRIHA guidelines. Low flow plumbing fixtures will be provided to conserve water. STP for capacity 155 KLD is proposed and its effluents will be utilized for gardening purpose.

## **Layout of the building**

The main purpose of the building is research work; thus the building has to accommodate all the required services with compliance of safety rules and regulations. Hence for appropriate accommodation

and accessibility of required services each wing is flanked by two corridors; internal corridor used for pedestrian movement which is well connected to all service cores and thus minimizing walking distance within the building and the external corridor is the service corridor which is shared amongst all the spaces along its length and has a separate access. The external corridor also helps in creating a buffer from direct sunlight and rain, thus minimizing the energy consumption for cooling down the space and also provides comfortable natural light for internal spaces. The structural Grid in the central area is 9m x 9m. The large column free space will provide flexibility in usage of building.

Each floor has three strategically planned service-cores at the corners, which are well equipped with fire-exit staircase, passenger lifts, one freight lift, toilet, differently abled toilet and a pantry/store. Building plan is largely divided into three parts namely; 1) Industrial units which comes in five different sizes namely the large unit which is 1000 sqm, medium size units which is 500 sqm, small unit type 'A' which is 100 sqm, small unit type 'B' which is 200 sqm, MSME (Micro Small and Medium Enterprise) rooms which are 50 sqm and accelerator room of 50 sqm.

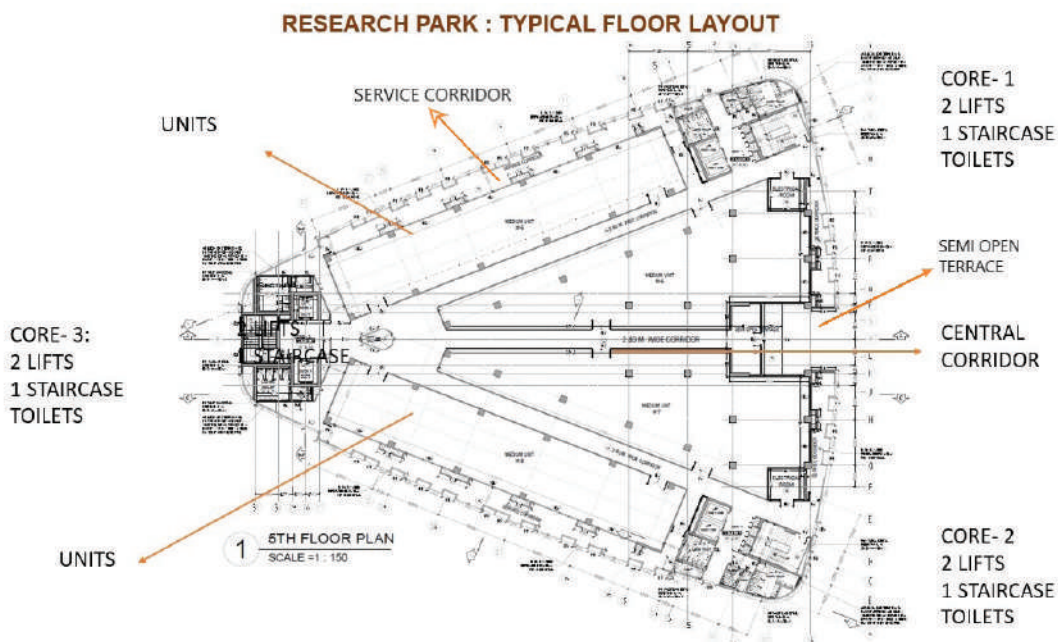

The lower floors of the building upto the seventh floor comprises of utilities and heavy engineering areas namely Workshop, Large units, Medium units and some small units & hence the floor height is kept 5.4 m & 4.5 meters. On all the heavily loaded floors there is one terrace area which serves the purpose of relief spaces and break-out spaces. On the eighth and ninth floor are the public assembly spaces like auditorium, video conferences and seminar rooms along with its allied spaces like discussion rooms and other facilities. The tenth floor is the food court which connects with the ninth floor by a staircase. The upper four floors comprises of small units, MSME rooms and accelerator, discussion rooms and research park office. Introduction of light well from the tenth floor up to the fourth floor will help in increasing the light quality and spatial quality of the lower floors. The façade of the building is proposed using combination of perforated GFRC & curtain glazing.



## **Structural Design Approach :**

The Structure has been designed with a combination of Ductile Shear Walls and Special Moment Resisting Frames. The lateral seismic forces are resisted completely by this combination of Shear Walls and Moment Resisting Frames. The structure is assumed to respond elastically to all the working loads. The structure will be analyzed and designed for all the primary load cases and load combinations using state of art software packages (ETABS) or manual analysis as required. Suitable load combinations are performed and performance of the structure in various states of service ability and collapse has been checked accordingly. Design is based on limit state design for reinforced concrete structures.

## **Electrical& Mechanical Services Design :**

### **Electrical**

1. Bus ducts/ rising mains have been preferred instead of cables for the Research Park building resulting in simple power distribution system.
2. There are dedicated shafts for rising mains / power supply cables and low voltage lines.
3. Shafts are protected by fire proof doors and at every floor fire barrier is provided to curb the flow of smoke from one floor to another.
4. There is provision of emergency supply for fire and life safety. These are routed through separate duct independent from normal supply.
5. There is provision for emergency lighting and escape lighting. Escape path shall be illuminated continuously.

### **HVAC and Smoke Control**

Air cooled Variable Refrigerant Flow (VRV)/ DX – Type air conditioning system has been proposed and the air conditioning system has been designed to provide year round thermal environmental control. The air conditioning system shall consist of outdoor units, fan coil units, copper piping, air distribution system, insulation, control wiring, etc. The refrigerant used shall be CFC/HCFC free. The outdoor units of both common areas and research laboratories shall be located on the ledge provided at each individual floor. As the false ceiling is proposed, the indoor units shall be of any suitable type (Cassette, Ducted). There is separate AHU for each floor so that return air of one floor will not pass to another floor thus reducing flow of smoke from one floor to another in case of fire.

### **Fresh air**

Fresh air required for all common areas has been taken from Energy Recovery Wheels unit and for video conference, auditorium, seminar room etc. natural fresh air has been taken from peripheral area through ducting.

### **Toilet Ventilation**

The toilet ventilation system shall be provided at 15ACPH. The Toilet exhaust shall be achieved with the help of exhaust grills and GI duct network, which shall carry the exhaust air and throw it with the help of exhaust air fan at terrace level. Similarly, kitchen exhaust shall be designed for 40 ACPH and shall be achieved with the help of grills, GI duct network, scrubber and exhaust fans located on the terrace floors.

### Staircase & Lift well pressurization

All lift lobbies & staircases shall be pressurized with tube axial fans. The tube axial fans shall be placed on the terrace floor ceiling to pump in fresh air, in the event of a fire, so as to maintain the staircase & lift lobby under positive pressure of 50 Pa, to prevent the ingress of fire / smoke into the staircase & lift lobby. Two lifts per core shall be pressurized to prevent the ingress of fire / smoke in case of fire. This shall be achieved with the help of tube axial fans placed on the terrace floor in front of lift cores, which shall pump in fresh air into the lift core to maintain positive pressure of 50 Pa.

### Fire fighting system

High Rise building being very sensitive to fire fighting and evacuation needs to be carefully planned keeping in view the services and evacuation plans. The Research Park building is complying the stringent municipal fire norms as below:

The building abuts on 12 mtrs. Wide Road on North and south side.

### Refuge area provided as under

Refuge floor	Refuge area (required)	Refuge area (proposed)	At the height from Ground level.
4 <sup>th</sup> floor	651.00 sqm	851.00 sqm	22.80 m.
11 <sup>th</sup> floor	651.00 sqm	651.00 sqm	53.10m.

1. Main underground tank is provided with capacity of 2 lakh litres for fire fighting system as per NBC. Overhead tank of 20,000 litres capacity provided over each staircase.
2. 1 no. Electric Motor driven Hydrant pump of capacity 2850 LPM against a head of 120 m, 1 no. Electric Motor driven Sprinkler pump of 2850 LPM against a head of 120 m, 1 no. Standby diesel pump of 2850 LPM and 1 no. Jockey pump capacity of 240 LPM at 120 m head each for Hydrant and sprinkler have been provisioned.
3. There is provision of fire hydrant near each staircase in 3 cores of the building. Whole building is provided with automatic sprinkler system.
4. Down comer system is also provided along with one booster pump of 900 LPM at a head of 35 m each for hydrant and sprinkler as gravity pressure will not be sufficient if fire occurs at higher floors.
5. There are 3 nos. of staircases provided with stairs width of 2.0 m.

### Fire Alarm and Public Address system

1. Analogue Addressable fire alarm system is provided with analogue addressable detectors. Main fire command station with GUI interface software is provided at the entry near reception which shows actual locations of various system and sensors on the floor plan.
2. Repeater panel is provided at every floor to monitor the status of various system and detectors at each floor.
3. Manually operated call boxes are provided near each staircase in 3 cores so that it is visible and easily accessible to all.

4. The building is provided with public address system with ceiling speakers mounted on each floors forming zones. Each zone can be evacuated in a phased manner by selective switching in call station.

### **Lifts**

1. Two nos. of lifts will be provided in Each core. (Total six nos. Lifts- Five nos. of Passengers)
2. Lifts of 20 persons capacity having speed 1.75 m/sec and one Goods lift of 1.0 Tonne capacity and speed 1.0 m/sec which will also serve as stretcher lift). One of the lift in each core shall be Fire lift as per norms.
3. There shall be an alternate electric supply of an adequate capacity apart from the normal electric supply of the building and the cables run in a route safe from fire, i.e. the lift shaft. In case of failure of normal electric supply, it shall automatically trip over to alternate supply.
4. Being high rise building, regeneration drive is proposed in lifts which will result in overall
5. Energy saving.

### **Sewage Treatment Plant**

STP of 155 KLD capacity designed for capacity equivalent to 80% of estimated daily water demand. STP of aerobic treatment system such as FAB/MBBR type shall be provided. The location of STP is approx. 200 mts from the plot at a low lying area. The location is chosen so that excavation can be minimized.

### **Integrated Building Management System (IBMS)**

For monitoring and controlling the energy consumption of the building a very robust computer and DDC (Direct Digital Controller) based system is proposed for monitoring and controlling HVAC (Chillers, AHUs, Fans, Pumps, CTs), ELECT (HT + Main LT + PCC Panels, DG), WMS (STP, Pumps) and LV ( Fire Alarm, Lift, Security).

### **Rain Water Harvesting**

Rainwater Harvesting is not proposed by IIT Bombay as site is located in close vicinity to three lakes and the ground water table is also very high at about 3 to 5 mts. Hence the RWH was not considered feasible by IIT Bombay

### **Green Building Norms**

The building is designed for minimum 3 star GRIHA rating. The provisions for Flyash concrete , AAC blocks, low e value glass, Water efficient fixtures , LED lightings , Solar water heaters, STP, RWH are proposed. The green building norms which are required to be followed during the construction such as sedimentation tank, protection of natural flora & fauna, proper handling of materials, waster segregation are also being followed at site. The GRIHA team has visited the site in July 2019 & their recommendations are complied.

### **CAR PARKING**

76 Nos. of open car parking shall be provided.

### **Landscaping**

The building is surrounded by patches of green belt all around the internal circulation road. The planters at the plinth level is provision for better aesthetics. The provision of grass pavers in parking lot & in open area is also provisioned. The trees which were cut have also been transplanted along the boundary wall of the plot.

### Others

- 1) Aviation obstruction light is provided which is required in High rise building.
- 2) Lightning arresters are provided.
- 3) CCTV & Access Control System
- 4) UPS



The B-25 building is a Residential Building, to accommodate the senior faculty members of IIT Bombay, The location for the B-25 Building is on a trapezoidal plot area adjacent to the CTR building. The building is proposed for Stilt/ground+20 with total height 69.65 mts. The building has been designed for GRIHA rating of 3 stars.

The salient features and design details are as below:

### Architectural Design Parameters:

#### 1. Orientation and Layout

The building is located in the close vicinity of Powai lake. The building is in cross shape and has four wings and a central common area. There are 4 flats in each floor except on 7<sup>th</sup> and 14<sup>th</sup> floor where refuge area provided in place of one flat. The building has been so aligned along with the existing CTR building so as to maintain the general layout of the area. Also this layout enables 3 out of 4 flats to have lake view of Powai lake. To increase privacy, all bedrooms and toilets have been planned at one end and kitchen at other end along with a large living cum dining room. Also though there is one central lobby the flat entrance have been so planned that each flat has their own private space in the lobby. The central common area consists of 2nos. of staircases and 2 nos. of lifts .The Total Built up area is 16600

Sqm. Built up Area of each flat is 165.66 Sqm. comprising of one Living cum Dining room and three bed rooms ( two with attached Toilets), one Guest bed room, kitchen and one common Toilet. Stilt/ground floor has been provided for 18 nos. car parking and space/ rooms for various services.

## 2. Natural ventilation

Being a residential building a huge emphasis has been laid on providing maximum cross ventilation. Hence the building has been planned as a cross shaped building with four wings and a common central area. This enables maximum area of the building open to natural air and sunlight, hence providing for cross ventilation and natural light in each flat. Also, full balcony has been provided in the living room to ensure maximum ventilation.

## 3. Water

Underground water storage tank of capacity 2,09,000 litres (including fire tank of 1,50,000 litres) has been planned for the building. Storm water management will be based on GRIHA guidelines. Low flow plumbing fixtures will be used to conserve water. Rain water harvesting has been proposed to conserve rain water.

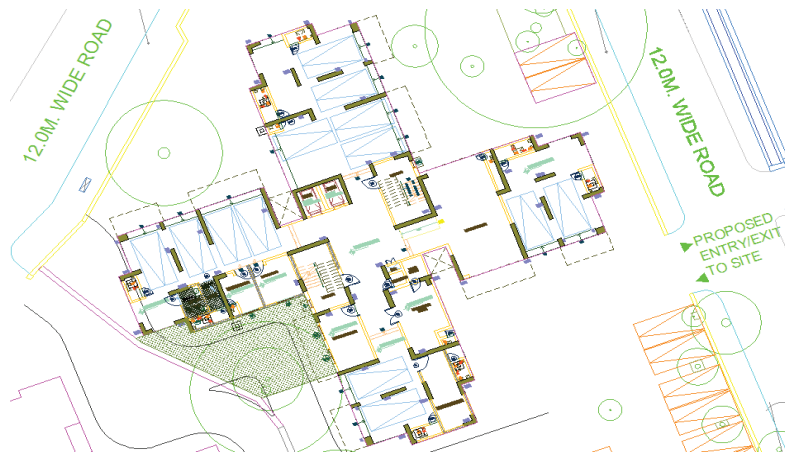

**Proposed Site Plan**

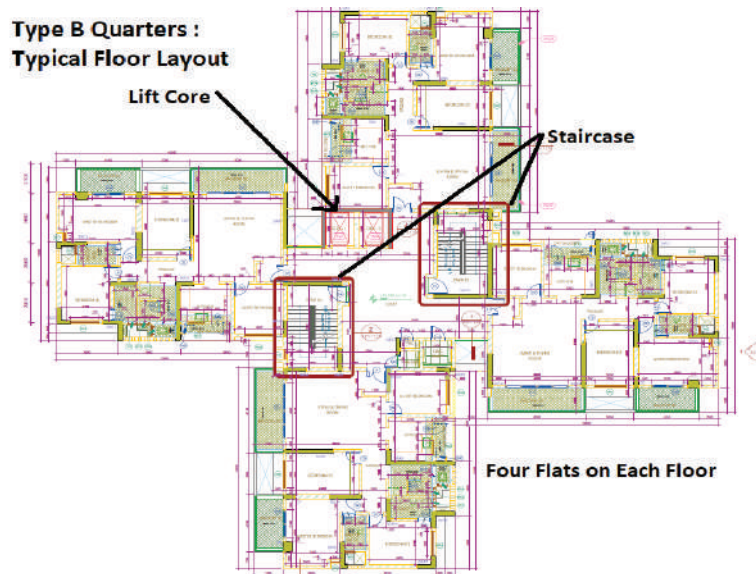

### Structural Design Parameters:

No.ofFloors	22 Floorsuptoterrace
Number of Floors along with height of floor	1. Stilt/Ground Floor : 4.5 m 2.1st to 20th Floor : 3.25 m  The height of stilt/Ground floor has been kept as 4.5 to take care of various services.
Totalheightofbuilding	69.6 m
Foundation	The B-25 building has been designed on pile foundations considering the lateral loads and the issue of dewatering and unmanageable storing of excavated soil at site. Piles of 800mm diameter and average depth of 10 meters were used. Total 182 piles divided into 5 groups each covered by a pile cap have been provided.
Type of floor slab & Structure	Conventional RCC slabs & Beams column moment resisting frame with shear walls. Typical shear wall width is 300mm.

### Electrical and Mechanical Services Design

#### Electrical Services

1. As it is a residential building cables have been used for power supply
2. There are dedicated shafts for power supply cables and low voltage lines.
3. Shafts are protected by fire proof doors.
4. There is provision of emergency supply for fire and life safety. These are routed through separate duct independent from normal supply.
5. There is provision for emergency lighting and escape lighting. Escape path shall be illuminated continuously.
6. Each flat shall be provided with Telephone/EPBAX, TV Antenna and Data sockets.
7. Energy efficient LED Fittings and BLDC fans shall be provided.

#### Fire-fighting system :

The Type B residential building is complying the stringent municipal fire norms as below:

#### Refuge area provided as under

Refuge floor	Refuge area (required)	Refuge area (proposed)	At the height from ground level.
7th floor	146.88	172.28 sq.mtrs	24.15m.
14th floor	146.88	172.28 sq.mtrs.	46.90 m.

1. Main underground tank is provided with capacity of 1,50,000 litres for fire fighting system as per fire NOC. Overhead tank of 20,000 litres capacity provided over each staircase.
2. 1 no. Electric Motor driven Hydrant pump of capacity 2850 LPM against a head of 120 m, 1 no. Electric Motor driven Sprinkler pump of 2850 LPM against a head of 120 m, 1 no. Standby diesel pump of 2850 LPM and 1 no. Jockey pump capacity of 240 LPM at 120 m head each for Hydrant and sprinkler have been provisioned.
3. There is provision of fire hydrant near entrance of the building all along the periphery. Whole building is provided with sprinkler system.
4. Down comer system is also provided along with one booster pump of 900 LPM at a head of 35 m each for hydrant and sprinkler as gravity pressure will not be sufficient if fire occurs at higher floors.

**Fire Alarm and Public Address system :** Provisioned in the building as per municipal specifications

### **Lifts**

1. Two nos. of lifts of 13 persons capacity and speed of 2m/sec will be provided. One of the lift shall be Fire lift.
2. Being high rise building, regeneration drive is proposed in lift which will result in overall energy saving.

### **CAR PARKING**

18 nos. of stilt and 60 Nos. of open car parking shall be provided for 78 nos. flats .

### **CCTV**

Provision of CCTV Systems comprising of 4 nos. of Dome/ PTZ Cameras, Cabling will be provided at main entrance lobby.

### **Other**

1. Lightning arresters are provided.

## **IV CONCLUSION**

With the emergence of dense urban spaces and mass transit systems the high rise building are the need of the hour and the planning of structural & E & M services play a crucial role in designing of High rise structures. The case study of Research park building and Faculty accommodation (B-25 building ) concludes that due diligence & analysis is required for planning, designing and execution of high rise buildings keeping in view the fire outbreak and evacuation purpose.

# SUSTAINABILITY IN SKYSCRAPERS

Ar. Bulbul Biswas, Senior Architect, CPWD

## Abstract

High rise buildings have been growing taller. These buildings have an enormous demand for energy during construction as well as during operation. Therefore it is necessary to examine the design factors that affect the energy consumption of these structures. Some recent designs have been successfully executed to harness solar and wind energy incident on these buildings.

A study of tall buildings and factors affecting sustainable design process through case studies and the emerging trends in design of tall buildings has been taken up to find whether tall buildings can be sustainable and to what extent.

## Introduction

The pace at which industrialization, urbanization and agglomeration has advanced, the imagination of yesterday has become reality of today. As industrialization triggered employment in the suburbs and towns, urbanization followed. The densification of population in urban areas led to high-rise buildings. Tall buildings are known to have high embodied energy and also require high operating energy. The heights of buildings kept rising, creating enormous demands on infrastructure. The trend of energy efficiency in tall buildings has been invoked as a response to the rising heights of the buildings as well as their dependence on infrastructure and amenities within controlled environments.

As recent construction trends have shown, high performance skyscrapers are achievable goals by adopting appropriate strategies to reduce both embodied energy and operational energy demands. Sustainability of skyscrapers must be viewed as a part of a city's sustainable growth. A zero energy building is a possibility through high performance design, integrated physical systems, a symbiotic building within its context and an interactive power grid with the buildings energy generating system. A tall building can accommodate many more people on a smaller land than would be the case with a low-rise building on the same land. A tall building is in effect a vertical transformation of horizontal expansion.

The full implications—the physiological, psychological, social, economic and environmental implications of vertical living, due to a great number of people confined in smaller spaces are yet to be manifest. Management of the skyscraper, evaluation of its performance and assessment of tenant satisfaction are other essential components to achieving more sustainable skyscrapers.

High-rise buildings are more expensive to construct per square meter, as they produce less usable space and their operation costs are significantly more than conventional buildings. One way to achieve increased efficiency of development is by creating clusters of tall buildings. Clustering of buildings in the form of tall buildings in densely built-up areas is the opportunity for creating open spaces like play-

grounds, plazas, parks, and other community spaces by freeing up space at the ground level.

### **Skyscrapers: Key Design Influencers**

The design of tall buildings is a combination of art and science. Foremost is the requirement of a profound respect for the forces of nature. These forces, namely, gravity, wind, seismic effects, thermal conditions and settlement collectively create the major design profiling for a building.

Architectural and structural requirements are the second important deciding parameters in the design of high-rise office buildings, and dictate the floor slab size and shape, leasing depth, structural frame, floor-to-floor height, vertical transportation and core layout.

Building services are the next design criteria to add to the functionality of the building. Fire services in tall buildings are planned so that an eventuality can be fought by fire personnel from inside the building rather than from outside.

### **Sustainability Considerations in skyscrapers**

In 1983, the UN established the **World Commission on Environment and Development** in an attempt to resolve the conflicts arising out of the aspirations of the developed and developing worlds. In 1989 they published '**Our Common Future**' or the **Brundtland Report**, which launched the concept of sustainable development and was reinforced at the Earth Summit in Rio.

**Sustainability in Skyscrapers** refers to the environmentally sensitive approach towards designing of tall buildings coupled with building management systems. The basic principle of Sustainability is "advancement that meets the needs of the present without overlooking the requirements of the future". The aim should be to obtain a building close to an ideal "ZERO ENERGY" building. A sustainable high-rise building is one which is efficient enough to perform all the building functions with the ability to produce an equivalent amount of energy that it consumes. It is environmentally conscious, energy saving and utilizes responsive and renewable materials and systems.

The embodied and operating energy of a skyscraper is higher than traditional low-rise construction. The challenge to achieve sustainability in skyscrapers is their inherent energy requirements for vertical transportation, heating, cooling and communications. They exert significant demand on infrastructure and transportation systems, creating overcrowding and traffic congestions. They do have advantages over low rise buildings that typically use more valuable land area than vertical high rise towers. However, it is important to consider skyscrapers in the context of urban density. When the land use and energy requirements of a skyscraper are compared to a small city, the advantages of concentrating people and services into a vertical city becomes clear. A pilot study on Urban Sustainability has shown that low-rise suburban development can require up to 5-10 times the road and energy infrastructure as high-rise. Thus, while a skyscraper as a stand-alone solution has an inherently higher embodied energy, high-rise can be part of an overall more sustainable solution when considered in a wider context.

The principal design factors that are crucial for achieving a high performance skyscraper are site con-

text, environment, structure and use of materials, energy consumption, use of water, ecological balance, community development etc. Due to the diverse disciplines involved, full integration of architecture and engineering is crucial. **This demands smart design, smart operation and integration.**

Integration of structure, mechanical systems and facades has been a significant factor in achieving energy efficient skyscrapers. The success of a green building lies in controlling the energy consumption. In a typical commercial skyscraper, the highest energy used is in operating the HVAC systems, followed by lighting systems and then by the other elements like elevators, plumbing and sewerage systems. Therefore in sustainable skyscrapers, priority is given to passive systems of heating and cooling over active and mixed systems.

One of the most efficient methods to achieve sustainability in tall buildings is **using prefabricated components manufactured in a controlled, offsite environment**. This solution is cheaper because it significantly decreases construction times by enabling construction and engineering challenges to be addressed before construction starts. It also reduces the number of workers, as fewer activities are carried out onsite - which in turn reduces noise and minimizes the impact of construction on the local area, including lower air pollution and CO2 emissions.

Another way to make skyscrapers more sustainable throughout their life cycle is to **improve the energy efficiency**. Energy efficiency in skyscrapers is achieved by minimizing the energy demand requirements through solutions like double skin facades, which improve insulation and minimize solar gain while still maximizing natural light. Energy efficiency can also be achieved by exploring solutions which incorporate on-site energy generation into the building design. Some of the possibilities to be considered are-

**Passive solar gain:** The site area can be utilized taking advantage of daylight together with the façade to gather sunlight by fixing the orientation of the building.

**Structure and Material:** The core provides structural stability and a steel framed structure can be made of recycled material for sustainability.

**Façade Technology:** Facades can be used to control the internal conditions by providing double/triple skin glazing with ventilation system.

**Harnessing Solar Energy:** The active solar energy can be utilized through technical installations like solar collectors or photovoltaic (PV) panels.

**Harvesting Wind Energy:** Higher altitudes of tall buildings face high wind speeds, which can be funneled towards wind turbines to produce more energy.

**Combined Heat and Power:** CHP system, also known as co- or tri-generation system is the simultaneous production of power, heat and chilled water. It avoids transmission losses and thereby cost savings.

**Fuel Cells:** A fuel cell is a reactor that combines hydrogen and oxygen to produce electricity, heat and water with high level of environmental qualification, as they are clean, quiet and efficient.

**Rainwater Harvesting:** This method collects rainwater onto roofs and stores in a tank before eventual use.

**Biomass Energy:** This refers to the concept of growing plants as a source of energy. Biomass fuel, like waste paper can be used to generate electricity and steam.

**Geothermal Energy:** Hot springs are an example of geothermal energy. Similarly, water is pumped through boreholes to obtain heated water, which is then used for space heating. This process is called borehole heat exchange (BHE) system.

An emerging powerful tool for innovative ways to create sustainable solutions in high-rise is integration with the digital environment. Tall buildings can be designed as platforms to take full advantage of the latest and future **SMART technology**. Thousands of SMART sensors feed data to the integrated Building Management Systems to allow the building to adapt and optimize for improved energy efficiency, safety and security. SMART technology integrated with architecture can improve comfort and productivity for the building users.

## Case Studies

Three case studies are discussed to understand the sustainability features used in some skyscrapers and to explain the constantly evolving meaning of sustainability in the emerging and fast developing world of tall buildings. Each building redefines the term sustainability in the context of its geographical location, infrastructure and local demands and constraints.

### Case Study 1.

Shanghai Tower, Shanghai

#### Project Details:

**Height:** 632 meters (2,073 feet)

**Floors:** 128 floors above ground and five below ground

**Total floor area:** 380,000 sqm (+141,000 sqm below ground)

**Completion:** 2014

LEED Gold certification

China Green Building Three-Star rating

#### Salient Features:

The Shanghai tower is designed as 9 cylindrical building zones stacked one over the other.



The building has twin layers of transparent facade.

The outer layer twists through 120 degrees as it rises.

The building has the fastest elevators in the world.

### Design Concept

The mixed use tower has created a sustainable living concept in a vertical city. The high density development has been combined with traditional lane housing concept with a communal open space. In Shanghai tower, the vertical neighbourhoods have their own sky garden to foster interaction and a sense of community. It has a mix of shops, restaurants, offices and hotels. It also has many public spaces & sky gardens throughout the building.

The design has 33% of the site as reserved green space, integrating the landscaped areas with architecture like the historic palace gardens and temple gardens of China. The outdoor spaces accommodate diverse activities, large and small. Each vertical neighbourhood rises from a sky lobby, a garden atrium that creates a sense of community and supports daily life with a mixed use program to cater to tenants and visitors. The sky lobbies function much like traditional town plazas and squares, bringing people together throughout the day. These civic spaces recall the city's historic open courtyards which combine indoors and outdoors in a landscaped setting.

To make the structure stable in strong winds, it has an innovative spiraling cylindrical shape that is aerodynamic.

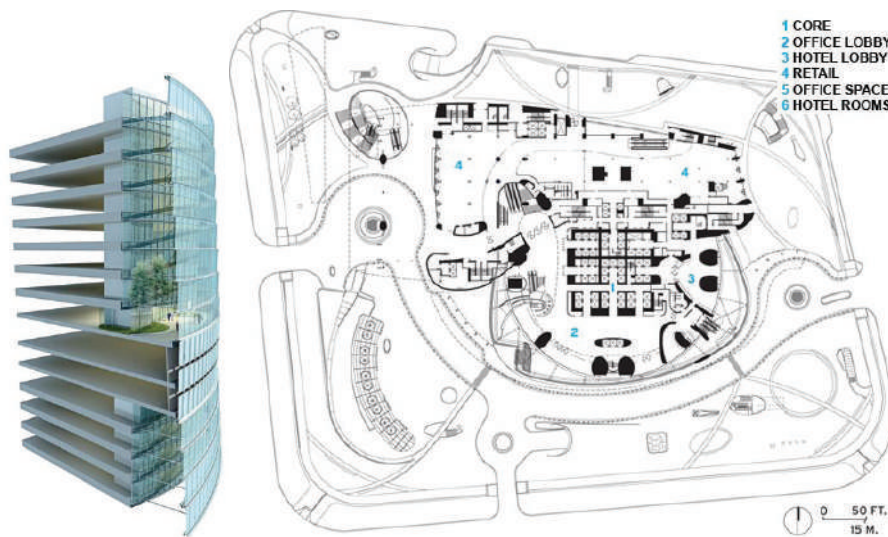

Fig 1. SITE PLAN

Fig 2. DOUBLE SKIN GLASS FACADE

### Sustainability features

The entire building is wrapped by two layers of transparent skins with a complex Curtain Wall Support System (CWSS). The outer skin gradually narrows at each floor level, giving the glass tower an elegant tapered profile, while a V-notch in the curtain wall accentuates the spiraling geometry. The inner skin

is cylindrical. The main feature considered for the exterior wall performance is based on a bioclimatic concept of a passive atrium system, where two skins are located in such a way as to create a large, full height atrium space capitalizing on all the benefits of captured air and provide the natural convection. The ventilated atriums serve as insulation cover which keeps the temperature stable and acts as a buffer between inside and outside (see Figure 2). As a result, the cool outside air is warmed in winter and heat from the building interior is dissipated in summer. In order to create a relatively comfortable atrium environment, the ventilation system is designed with a great degree of efficiency with only the first 15 feet (4.6 metres) of atrium mildly conditioned with the use of a perimeter Fan Coil Unit (FCU) that either heats or cools, primarily during weather extremes, leaving the majority of the atrium to be ventilated with a combination of natural updraft and regulated top exhausts, as well as with spill air on the first and last floor of each zone. And the condensation of moisture on the outer curtain wall in the atrium in winter is solved by equipping fins.

The ventilated atriums house landscaped public gardens (see Figure 3). These landscaped sky lobbies help to improve air quality, create visual connections between the city and the tower's interiors, and provide a place where building users can interact and mingle.

Building codes in China's urban districts are highly sensitive to the impact of sunlight reflecting off glass façades toward surrounding buildings. The ratio of glass on the building cannot be more than 70% and the glass has to have reflectance that does not exceed 15%. Therefore the light pollution category was the most impactful variable in the overall exterior wall concept design

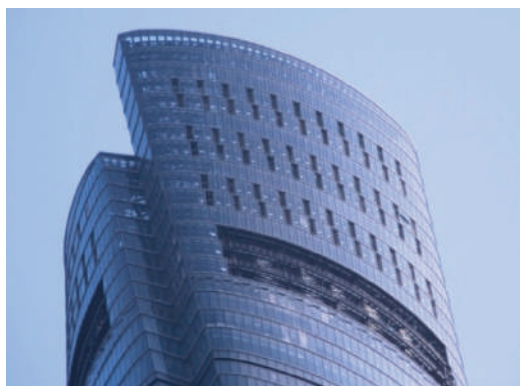

**Fig 3. SKY LOBBY**



**Fig 4. WIND TURBINES**

and glass selection. The exterior curtain wall glass ratio is very high, at about 87% (including spandrel area), and the interior curtain wall has a glass ratio of about 60%.

Ground source heat pump (GSHP) or Geothermal heat pump system exchanges heat between the constant temperature of soil and the building to maintain the comfort temperature of interior space. Because the underground soil temperature is relatively stable throughout the year, higher than the ambient air temperature in winter and, lower than the ambient air temperature in summer, therefore GSHP system is suitable for both heating and cooling.

Air-conditioning with ice thermal storage is green, cost-effective and reliable solution for cooling offices, schools, malls, convention centres and other buildings with daily comfort cooling requirements. Ice Storage is like a battery for a building's air-conditioning system. It uses standard cooling equipment, plus an energy storage tank to shift all or a portion of a building's cooling needs to off-peak, night time hours. During off-peak hours, ice is made and stored inside ice storage tanks. The stored ice is then used to cool the building occupants the next day.

Combined cooling, heat and power (CCHP) or Tri-generation is the simultaneous onsite generation of electricity, heat and cooling from a single fuel source. Waste heat from turbine provides energy to heat recovery unit, then produce heat and generate chilled water for air conditioning or refrigeration. This simultaneous generation from a single fuel source makes CCHP system highly efficient compared to conventional power generation, and making it the ideal solution for organizations which have significant cooling requirements. This system is installed in the lower energy centre which is set up in floor B2.

Skyscrapers are ideal for wind power, because of abundant wind resources on top of the building all year round. Hence Shanghai Tower design team chose this renewable energy. The wind power at the top was 2 to 3 times more than at ground level, 270 horizontally oriented wind turbines with the total capacity of 135kW are installed between the inner and outer curtain walls. In addition, there are 54 vertical axis wind turbines set on 565 to 569 metres height of the tower. With the daily average wind speed 6m/s, wind turbines at the top of the building will produce annually an estimated 157,500 kWh in renewable energy and will power the exterior lighting and public spaces. (see Figure 4).

For the effective conservation of water resources the water treatment system was optimized to recycle the bath wastewater from the hotel area, the toilet wastewater from the office area and the rainwater collected by the building. The treated water is used for basement garage washing, plant irrigation and toilet flushing etc.

Elevator is one of the largest energy consuming equipment of high-rise buildings. There are 106 elevators in Shanghai Tower, few of those are double deck elevators. The real benefit of the double deck elevator is that while people can be transported in the same time as single deck elevators, the required shaft area is reduced. (see Figure 4).

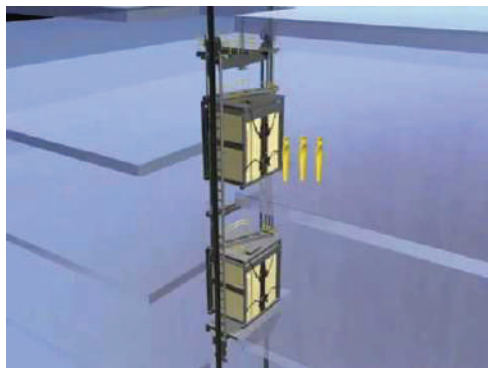

**Fig 5. DOUBLE DECK ELEVATOR**



**Fig 6. VIEW OF SHANGHAI TOWER**

Sustainable Construction Management - In order to preserve nature resources and lower the negative influences of construction on the surrounding environment, sustainable construction management was implemented to Shanghai Tower. It mainly addressed soil balance, construction road use, noise, dust, water, light pollution, local material use and recycling construction solid, etc.

To save energy and provide extra protection, the tower is built like a thermos bottle with an outer skin consisting of two-layer glass facades, some water is recycled, some rain water is caught and reused, and wind turbines and solar panels help to produce energy.

## Case Study 2:

### Bahrain World Trade Center, Bahrain

#### Project Details:

**Height:** 240 meters (790 feet)

**Floors:** 50 floors

**Total floor area:** 88617 sqm

**Completion:** 2008



The Best Tall Building Award in 2008 for Middle East and Africa

EDIE Award for Best Use of Technology within a large scheme for 2007

LEAF Award for Best Use of Technology within a Large Scheme for 2006

#### Salient Features:

It is the first skyscraper in the world to integrate wind turbines into its design.

Buffer spaces were created between the external environment and indoor air conditioned spaces.

Dynamic Insulation through deep gravel roofs has been used in some locations.

Sloping Elevations have balconies with overhangs to provide shading.

Use of high quality solar glass, where shading is not provided to glazing.

Variable volume chilled water pumping has been used, which operates with considerably less power.

The site has extensive landscaping.

#### Design Concept

The plan remodeled a hotel and a shopping mall in a prestigious area near the Arabian Gulf. The WTC is an extension of the Hotel complex and comprises two 50-storey sail-shaped commercial office towers, which taper to a height of 240m and support three 29m diameter horizontal-axis wind turbines. The

podium provides a one-storey extension to the existing shopping mall. The towers are integrated on top of the three-storey podium, which accommodates a new 9,600 sqm shopping centre of boutique stores, restaurants, food court, hotel space for the Sheraton, business centre, health club and spa, and 1,700 onsite parking spaces. The two towers provide 50,000 sqm of office space over 41 storeys and a viewing deck on the 42nd level.

### Sustainability features

The two towers are linked via three sky-bridges, each holding a wind turbine, totaling to 675kW of wind power production capacity. Each of these turbines is 29 m (95 feet) in diameter and aligned towards north, which is the direction from which air from the Persian Gulf blows in.

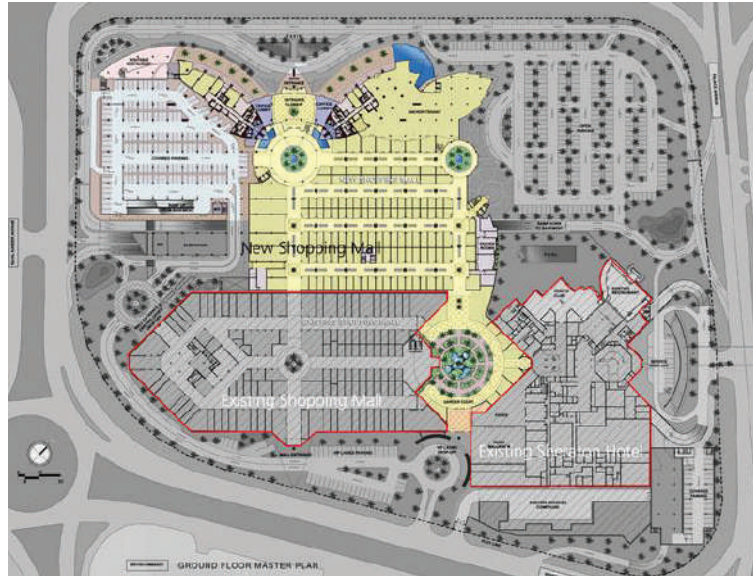

Fig 7. SITE PLAN

The sail-shaped buildings on either side (see Figure 8) are designed to funnel wind through the gap to provide accelerated wind passing through the turbines. This was confirmed by wind tunnel tests, which showed that the buildings create an S-shaped flow, ensuring that any wind coming within a 45° angle to either side of the central axis will create a wind stream that remains perpendicular to the turbines, significantly increasing their potential to generate electricity.

The wind turbines are expected to provide 11% to 15% of the towers total power consumption, or approximately 1.1 to 1.3 GWh a year. This is equivalent to providing the lighting for about 300 homes. They are expected to operate 50% of the time on an average day. (see Figure 9).

Additional high-quality solar glasses used with low-shading coefficient reduce the air temperature of the building. Balconies to the sloping elevations with overhangs also provide appropriate shading. The opaque fabric elements of the building are given enhanced thermal insulation.

There is a connection to the district cooling system, which works on sea water cooling /heating rejection and has a high-energy conversion efficiency contributing to low-carbon emissions. Chilled water is used to cool the building and the entire complex. There are also reflection pools at entry points of the build-

ing, providing local evaporative cooling. Moreover, extensive landscaping reduces site albedo, generates CO<sub>2</sub> and shades the on-grade car parks. Additionally, low-leakage, openable windows installed in the building support the mixed-mode operation in winter months.



**Fig 8. PLAN & ELEVATION**

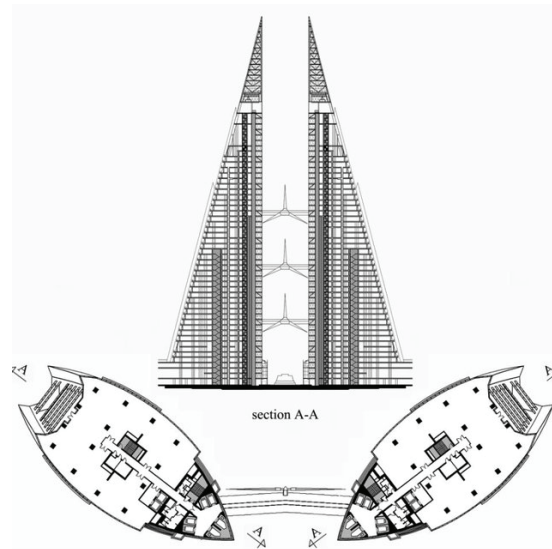

**Fig 9. WIND TURBINES**

Inside the building, dense concrete core and floor slabs balance loads and reduce peak demand contributing to a low use of air and chilled water transport systems. Variable-volume chilled water pumping takes less power to operate than conventional pumping.

The building has dual drainage systems to segregate foul and waste water and allow grey water recycling to be added at a later date. A solar-powered road, amenity lighting and high-frequency, energy-saving fluorescent lighting with zonal control are also included in the design of the building.

The other materials and details that add to the energy efficiency of the building are, buffer spaces between the external environment and indoor air-conditioned spaces to reduce conductive heat gain, deep gravel roofs at some locations to provide insulation, balconies to the sloping elevations with overhangs to provide shading, high quality solar glass with low shading coefficient to reduce solar gains, heat recovery system, enhanced thermal insulation for opaque fabric elements, variable volume chilled water pumping to operate with significantly less pump power, energy efficient, high efficacy, high frequency fluorescent lighting, dual drainage systems to segregate foul and waste water and allow gray water recycling to be added later, reflective pools to provide local evaporative cooling and solar powered road and amenity lighting.

Case Study 3:

Kohinoor Square, Dadar Mumbai

Project Details:

Height: 203 meters (666 feet)

Floors: 52 floors

Total floor area: 255,000 sqm  
(2,750,000 sq ft)

Completion: 2019

The Kohinoor Square Building is one



of the first Skyscrapers in India to achieve a Gold (LEED) Certification from Green Building Council.

Salient Features

Kohinoor Square is an iconic 52 story semi-twin, diamond shaped mixed use skyscraper located in Shivaji Park, Mumbai. The complex consists of 3 towers, West, Central and East. The first five floors of the main building is used for a high end shopping mall and the remaining 47 floors are used for offices topped by a five star hotel. It has a four story high entrance lobby and 3.9 m floor to floor height, with a vertical circulation core in the centre. The tower also has a heliport on the top.

The first 13 floors of the residential building are used for parking of both the buildings and the remaining 19 floors are residences.

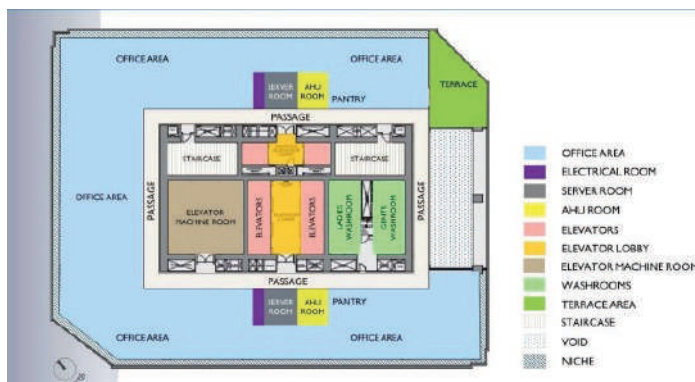

Fig 10. SITE PLAN

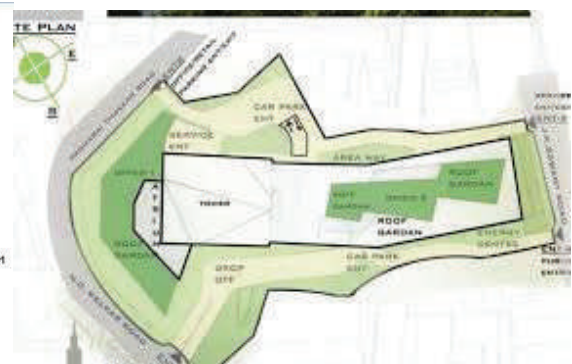

Fig 11. FLOOR PLAN

## Sustainability features

- Rain Water Harvesting
- Sky Gardens
- High Performance Façade
- High Efficiency Ventilation System
- Daylight Harvesting and Dimming control
- Black and Grey Water Reuse
- Environmentally Preferable Material
- Green Roof
- Energy Centre
- Native Adapted Landscape
- Onsite Waste Water Treatment
- Recyclable Sorting and Collection
- Natural Ventilation



Fig 12. SUSTAINABILITY FEATURES

The structure and shape of the building were based on extensive wind load studies. The building design makes it environment friendly by using technologies (see Figure 12) such as floor to ceiling insulated glazing to contain heat and maximize natural light. There are 15 double height landscaped sky gardens (see Figure 13) and a dozen double height terraces to act as refreshing breakout zones. The tower also has a grey water system to catch rain water for reuse. Air entering the building is filtered, as also the air exhausted is cleaned. Vegetated wall systems (see Figure 14), native adapted landscape, daylight harvesting and dimming



Fig 13. SKY GARDENS



Fig 14. GREEN WALLS

controls, natural ventilation, green roof, black and grey water reuse, on-site waste water treatment, low flow faucets, dual flush toilets, storm water & rainwater management systems are used for as environment friendly features.

## Conclusion

Future sustainable high-rise buildings will need to be more energy efficient and functionally diverse with emphasis on multi-functional tall buildings that encompass living, working, retail and leisure spaces into a single building. The relationship of tall buildings with their urban infrastructure like transportation, water and waste distribution, energy, heating and cooling must be considered with its impact on the city's physical resources and availability, in terms of sustainable design. Finally, future concepts of mega-structures will have to be constantly analysed and reinvented to address the emerging and evolving needs and aspirations of humanity, taking care to provide a viable, environment friendly solution.

In the larger context, apart from energy needs, carbon emission effects, air pollution, etc., skyscrapers also need to deal with Urban Heat Island effect, disturbance to natural winds, effect of rising sea level on shoreline skyscrapers, waste management, etc. Tall buildings exert an adverse effect on the micro-climate due to wind funneling and turbulence around their bases, causing discomfort to pedestrians. They cast a shadow on nearby buildings, streets, parks and open spaces, and they may obstruct views, reduce access to natural light, and prevent natural ventilation. There also exists zero experience in demolishing skyscrapers as apart from World Trade Center in 2001, no building over 200 meters has ever been demolished. The technical expertise to enable deconstructing skyscrapers at the end of their life cycles with minimal environmental impact needs to be developed.

Further research is required to examine the social sustainability of tall buildings. There is a need to investigate the impact of high-rise living on social behavior and community and lifestyle in different places and cultures. Given the world's aging population, the needs of the elderly and disabled concerning high-rise living warrant thorough examination. In addition, it would be useful to observe the effects of high rises on inter-generational living. High-rise design should reflect the significant differences in needs of seniors versus young, family versus single, homebound versus professionals and families with children. Thus, just as a hotel provides a choice of restaurants, similarly a future tall building may provide a choice of schools, hospitals, leisure activities, play areas, socio-cultural hubs, etc.

Looking to the future, just as the mile high skyscraper visualized by Frank Lloyd Wright in his 1957 book, *A Testament* seems around the corner, a complete city within a building comprising of all needs of a person except tourism, adventure or acute emergency may soon become a reality.

## References

1. Overview of Sustainable Design Factors in High-rise Buildings (2008), a CTBUH research paper by Mir Ali & Paul Armstrong
2. Sustainability & Tall Buildings – Recent Developments and Future Trends (2010), a CTBUH research paper by Mir Ali & Paul Armstrong
3. Trends, Drivers and Challenges in Tall buildings and Urban Habitat (2008), a CTBUH research

paper by Antony Wood, Executive Director, CTBUH

4. Super Tall building Design Approach (2009) by Hi Sun Choi, Principal, VP, Thornton Tomasetti
5. High Rise buildings can be sustainable (2018), by Shonn Mills & Annette Bachand
6. Emerging Trends in Tall Building Design: Environmental Sustainability Through Renewable Energy Technologies (2014), by Mohammad Arif Kamal & Smriti Saraswat
7. Sustainable High-rise construction in Shanghai: Case study- Shanghai Tower (2015), by Gina Letizia Lau
8. Shanghai Tower (2014), by Prof. Anna Nichols
9. Shanghai Tower Multi-storied Structure (2014), by Diksha Hans & Sanskriti Jindal
10. Bahrain World Trade Centre (2018), by Rajat Nainwal
11. World Trade Centre Bahrain (2015), by Dishant Routela
12. Bahrain World Trade Centre: The first large scale integration of wind turbines in a building (2007), by Richard F Smith & Shaun Killa
13. A multi-faceted development Kohinoor Square (2015), by Sandeep Shikre Architects in Urban Insight
14. Kohinoor Square(High Rise Mixed Use Building) –Mumbai case study (2017), by Anurag Mathur, IIT Roorkee
15. Case Study Kohinoor Square Mumbai (2019), by Taba Tapu, NIT Hamirpur

# PLUMBING IN HIGH RISE BUILDING

**Er. Girish Chandra Mishra,**

B.Tech. (Hons.) (BHU-Varanasi), MBEM (Distn.) (SPA-New Delhi)

Principal Consultant & Director, SAVIRAM Engineering Consultants Pvt. Ltd, NOIDA

## **Abstract**

Plumbing in high rise building relates to hydraulic zoning in water supply and ventilation in drainage piping for pressure balancing. Constant water flow at adequate pressure in water supply and quick disposal of waste water through horizontal branch & vertical piping are important design aspects. No water leakage, no odour and no noise are primary ethos of a good plumbing system.

## **Introduction**

High rise building has been defined in India as roof of the last habitable floor being 15 m or more from adjoin ground level. In international codes the same is taken as 23 m. Water conservation norms demand dual plumbing in form of recycled sewage treatment water being used for non-potable applications like flushing, gardening and industrial cooling and accordingly separate cold water lines for potable and non-potable application need to be incorporated. The drainage system of soil and waste piping needs to be adequately sized and proper venting provided so that there is no backflow problem and no noise is created in conveyance of the wastewater. If required, gray water and black water may be segregated and separately treated based on end user's requirement for recycling. Rainwater piping shall be planned so that the pipes are able to carry adequate runoff based on maximum rainfall intensity of 1 in 5 year storm using the meteorological data. Ease of installation and maintenance with easy access from internal spaces shall be essence of the architectural space planning in a high rise building. Adequate precaution shall be taken for sealing of the internal vertical shafts to avoid any fire risk in future.

## **Water Supply**

Since 2006, use of recycled water only for non-potable water is mandated in India for buildings having built-up area (BUA) of 20,000 sqm or more and this has led to dual water supply planning in building projects. Many state building codes have mandated wastewater recycling plant for discharge exceeding 10,000 litres/day (DELHI-since 1996) while some municipal corporations mandate use of recycled water for non-potable applications for BUA of 5,000 sqm [Ghaziabad-2019]. The IS codes specify minimum water pressure of 0.18 bar at consumer's tap subject to a maximum operating pressure of 4.2 bar. For higher pressure pressure controlling devices are recommended.

The quality of water to be supplied on the tap is to be determined in accordance with IS:10500 'Drinking Water Standards' for potable water. For non-potable flushing & gardening water quality CPCB/NGT norms wrt BOD, COD, TSS and Fecal Coliform are to be followed. For industrial cooling, further water

treatment in form of softening may be required as per equipment requirement. The water storage and distribution of potable and non-potable water system has to be independent and sanitary separation shall be maintained between the two storage tanks to avoid any contamination.

The water distribution can be either through gravity or through pumping set. In either cases, it is recommended to divide the vertical water distribution piping in different hydraulic zones so that proper pressure control can be done for all levels and in case of failure of one circuit users on all floors do not suffer. The zoning of water distribution network may be adopted for 7 to 9 floors. The recommended maximum permissible velocity is 2.4 m/s for water distribution.

In National Building Code of India 2016 Part 9 Plumbing Services Section 1 Water Supply, under Clause 4.7.3.3, maximum flow rate and flush volume for sanitary fixtures have been specified as extracted below:

Plumbing Fixtures/Fittings	Maximum Flow Rate (@4.2 bar)
Water closets	6 litre/flush
Urinals	3.8 litre/flush
Lavatory, metered faucet(public)	1 litre/use
Lavatory, faucet (Private)	8 litre/min
Sink, faucet	8 litre/min
Bidet, hand held spary	8 litre/min
Shower head	10 litre/min

The design of supply pipe of fixtures is based on the number and kind of fixtures installed; fixture unit flow rates and probable simultaneous use of these fixtures. Commercially available pipe sizes are used against the size arrived by actual design. Hazen and William's formula is used for pressure pipe size calculations.

## Drainage

The soil and waste drainage system to be adopted will depend on the type and planning of the building in which it is to be installed and can be any of the following options:

- One pipe system: Common soil and waste vertical stack with provision for ventilation of each and evert trap. The horizontal branch pipe for soil and waste shall be separate and connected to a common vertical stack. Minimum 200 mm vertical separation in the branch connection to vertical stack between soil and waste to be maintained. The system will have a drain vertical and a ventilating pipe.
- Two pipe system: Separate soil and waste vertical stack. Ventilating pipe provision to be done for more than 5 levels or horizontal branch pipe connection to vertical stack exceeding 2.4 m for soil and 3.5 m for waste. The vertical stack will have minimum 2 drain pipes and nil, 1 or 2 ventilating pipes.
- Single stack system: The piping in which there is no trap ventilation and common soil and waste pipes. Minimum 100 mm recommended for vertical stack. Horizontal branch pipe connection to vertical stack limited to 2.4 m for soil and 3.5 m for wastepipes. Minimum 200 mm vertical separation in the branch con-

nection to vertical stack between soil and waste to be maintained.

All drain fittings connected to the vertical stack or underground sewer shall have minimum 50 mm water seal. Wastewater flowing in a vertical pipe adheres to the perimeter of the pipe acting like a sleeve of water with hollow column of air, flowing vertically down until it reaches a ratio of approximately  $1/4^{\text{th}}$  of pipe cross sectional area. The vertical gravity flow is for a velocity upto 4.5 m /sec while horizontal pipes are designed between 1.2-2.4 m/sec. When vertical pipes offset to horizontal, the fluid flow velocity drops considerably causing lowering of air pressure on the downstream side creating a hydraulic jump and filling entire pipe dia. This can be controlled by effective use of vent connection at the end of the stack and not connecting the 1<sup>st</sup> level of fixtures to horizontal pipe portion of vertical stack. Good design shall also compensate for thrust that occurs at change of direction which may include increasing the horizontal drainage pipe sizing and/or slope, using thrust block or using restraining joints that mechanically anchor the fittings to the entering and leaving pipes.

The discharge of water through a domestic drain is intermittent and limited in quantity and, therefore, small accumulation of solid matter are liable to form in the drains between the building and underground sewer. There is gradual shifting of these deposits as discharge takes place. Gradients should be sufficient to prevent these temporary accumulations from building up.

Drainage pipe stacks are sized for  $1/3^{\text{rd}}$  of their carrying capacity. Plumbing codes provide values of drainage fixture units for each sanitary fixture. Different values of fixture units are based on the nature of occupancy and the place of installation. Sizing of drainage pipes is based on the cumulative values of drainage fixture units connected to the pipe. A vertical pipe will always have a larger carrying capacity when compared to a horizontal pipe of the same size. Carrying capacity of horizontal pipes is dependent on the gradient provided. Irrespective of drainage fixture unit loads, the minimum size for the fixture shall be adopted. The minimum size of the horizontal pipes is important to ensure self cleaning velocities in sewer.

A ventilation system is integral part of drainage which is responsible for the flow of air in the drainage piping network. Since the drainage is through gravity, absence of air will make it erratic. When a water flows in a conduit to a lower level, air must be added to replace the liquid else a negative pressure zone will occur. If this zone is near a fixture, air will be drawn into the drainage system through the fixture trap with an easily identifiable gurgling noise and very slow drainage. This condition leads to poor performance throughout the drainage piping and water seal loss in traps due to siphoning. The solution for this problem is venting, starting from individual fixture vent leading to branch, circuit and loop vents at appropriate locations. In a high rise drainage stack, the vent stack shall provide pressure equalization and relief throughout the system.

## **Rainwater Piping**

The design factor for rainwater piping are intensity of rainfall and time of concentration selected for rainwater pipe. A bell mouth inlet at the roof surface is found to give better drainage effect. The effective strainer area should preferably be 1.5 to 2 times the area of pipe which it connects to enhance the capacity of rainwater pipes since the outlet pipe can be designed like a weir. The roof area (RA) for

drainage may be worked out by following formula :

$$RA = 0.084 \times d^{(5/2)} / I$$

Where

RA = roof area in sqm,

d = diameter of pipe in mm, and

I = intensity of rainfall in mm/hr.

The number of rainwater pipes shall be decided on the basis of roof area and number of downtakes available. In addition to conventional rainwater piping design adopted as per above details, siphonic rainwater drainage system which works on induced vacuum system, can be adopted for large roof area, which is based on 100% cross sectional area of the pipe being used for rainwater drainage with enhanced velocity of 8-10 m/sec, reducing the number of downtakes substantially.

### **Sewage Treatment and Recycling Plant**

Based on the building design and requirement, either 100% of gray and black water or only gray water may be treated in individual buildings and reused for non-potable applications like flushing and horticulture. It can be further reused for industrial cooling viz, HVAC & DG cooling tower make-up post tertiary treatment including softening. Environment Impact Assessment (EIA) norms prescribe only recycled STP water to be used for construction, flushing, irrigation and industrial cooling and no fresh water is allowed for non-potable applications. National Green Tribunal vide its order dated April 30, 2019 has fixed the following norms of treated effluent for all new STPs in cities with population over 10 lakhs:

pH	5.5-9
BOD	10 mg/l
Total suspended solids (TSS)	20 mg/l
COD	50 mg/l
Total Nitrogen	10 mg/l
Total Phosphorous	1 mg/l
Fecal coliforms	Desirable - 100 MPN/100 ml Permissible - 230 MPN/100 ml

Real time on-line monitoring effluent quality through cloud network is also being mandated by State Pollution Control Boards for Sewage Treatments Plants being installed in buildings. The selection of STP technology hence shall be based on type of occupancy and expected occupation pattern since the biological STPs need minimum 20-25% of design sewage load of the building. Minimum two modules of 50% capacity each are recommended for ease of operation and maintenance. The exact configuration of STP modules shall depend on minimum like sewage generation in initial days of commissioning of

the building. The influent load parameter shall also be accordingly selected based on internal building sewage generation and import of outside sewer, if so required for non-potable application like HVAC cooling tower make-up for water cooled AC chillers, if so planned in the complex. STP processes like Moving Bed Bio-film reactor (MBBR), Sequential batch reactor (SBR), Membrane Bio Reactor (MBR), Soil-bio Technology (SBT), Phytoid Technology, are some of the processes being used in the industry based on the project requirement and availability of area/land.

## Water Metering

It is important to note that with advent of dual plumbing and mandatory installation of STP in buildings having area more than 20,000 sqm [EIA norm] or discharge in excess of 10,000 litre/day [UBBL2016], it is important to plan for bulk metering at plant room level and sub-metering at apartment level in a high rise building. The water supply piping hence needs to be planned accordingly. It may be noted that fire norms stipulate all high rise buildings (except apartment housing for which the norm is for 45 m and above) shall have provision for automatic sprinkler fire extinguishing system. The cold water domestic and flushing pipes can follow the same route as the automatic sprinkler piping and necessary coordination with Architectural and Structural planning done. This system shall reduce the number of cold water downtakes in each and every toilet & kitchen shaft of an apartment flat significantly reducing the quantity of water supply piping and appurtenances. This system is prevalent all over the world and installed in many high rise buildings (upto 50 floors) already in Delhi-NCR. Water metering has helped in establishing the data bank for actual water consumption in buildings and rationalization of storage, treatment and distribution network.

## Case Study

Relevant plumbing drawings of two projects (One Residential and One Mixed Use Retail-cum Office Commercial) in Vatika IndiaNext Township in Sec 82-83, Gurgaon are enclosed to explain the plumbing system in high rise buildings. Aspects like dual plumbing, exposed drainage pipe below the slab and above the false ceiling, hydraulic zoning, drainage venting, water metering can be seen in the shared project details. The brief details of the projects are listed below:

### **Project no. 1 : SovereignNext Apartment Housing at Sec-82A, Gurgaon**

Site Area = 7.5 Acres

FAR = @1.75 = 53,114.5 sqm

Ground coverage = 35%

No. of apartments = 240 (208 Main+32 EWS)

Configuration of buildings :

(Terrace of the highest occupied floor): Block **A** (G+27) : 93.150 mt., Block **C, & D**

(G+7) : 27.050 mt., Block **E** (G+12) : 43.30 mt., Block **F, G & H** (G+6) : 23.75 mt.,

Community Building (G+1) - 7.825 mt., Convenient shopping attached with EWS

ground floor - 3.45 mt. , EWS (G+3) : 12.400 mt .

Number of basement : Two (2)

Upper Basement = 11420.717 sqm (Level: -4950 mm)

Lower Basement = 7734.787 sqm (Level : -8450 mm)

**Project no. 2** : Mixed Use Retail & Business Commercial @Sec-83, Gurgaon

### Project Brief:

Site area	1.605 Acres
Available FSI	1,57,500 sqft
Total Area planned	1,60,011 sqft
Ground coverage	@50%= 34,950 sqft
Maximum height	Wing B = 44.325 metres

### Building-wise area break-up:

Building name	No. of floors	Area in sqft
Wing A1-Retail	G+2	22,216 sqft
Wing A2 –Retail	G+2	25,597 sqft
Wing A2-Business	Lvl 3+4	12,618 sqft
Wing B-Retail	G+1	17,284 sqft
Block B- Business	2-10 lvl	69,858 sqft
Basement	(LGF)retail	12,438 sqft
Total FAR		1,60,011 sqft
Basement area (3 lvls)	(3 lvls)	1,15,767 sqft

### Conclusions

Plumbing in high rise buildings in India is promoting the concept of water conservation as mandated in Environmental norms initiated by Govt. of India in 2006 and inherent part of building bye-laws now. Dual plumbing, hydraulic zoning in water supply, venting in drainage piping including at horizontal transfer at lower levels , water metering aspects are being incorporated in building system design and necessary coordination between Plumbing Engineer and Architects is to be initiated from the concept stage itself. Plumbing system design shall strive for good water pressure and constant flow at all levels of a high rise building and drainage system shall be free of any leakages, odour or noise.

### References:

1. SP7: National Building Code of India 2016 Volume 2 Published by Bureau of Indian Standards, India
2. SP35: Handbook on Water Supply and Drainage Published by Bureau of Indian Standards, India
3. Plumbing Systems & Design ,May-June, 2007 Published by American Society for Plumbing Engineers (Pages 30-34)

# RECENT ADVANCEMENTS IN VERTICAL TRANSPORTATION SYSTEM IN MEGA HIGH-RISE BUILDINGS

Er. Narendran R., General Manager ITEC, Kone Elevator India P. Ltd.

## Abstract

Efficient vertical transportation system is a critical component of tall building development and construction. This paper deals with recent advancements in elevator technology for efficient design of vertical transportation system and to enhance people flow experience.

## Introduction

- Mega Highrise Building constructions are growing at a very rapid rate in the world and hence the need for Elevators that can go to greater heights is also increasing. With the current available steel ropes elevator technology going to heights beyond 500 mts in a single run is a challenge.
- In high rise buildings the shaft design is critical as the air pressure is different on ground floor & the upper floors. The enclosed shaft is like a piston & cylinder thus the displaced air due to lift car movement escapes through narrow gaps between the car, this can increase the speed of the air around the car dramatically, often to levels more than twice the speed of the car thus resulting into the following;
  - i. High noise level in car
  - ii. Buffeting while passing doors
  - iii. Whistling of car & landing doors
- Stack & piston effect is a common phenomenon in high rise buildings.
- Seismic sensors have to be provided to support rescue operation.
- People flow guidance system should be provided so that the passengers reach their destination in the minimum time possible.
- Integration of access control and security systems with the vertical transportation system is necessary for smooth passenger flow.
- Reduction in energy consumption and regeneration optimize the power consumption.

## Worlds 10 Tallest Buildings

Rank	Building	City	Country	Height			Built
				m	ft	Stories	
1	Burj Khalifa	Dubai	United Arab Emirates	829.8	2,722	163	2010
2	Shanghai Tower	Shanghai	China	632	2,073	128	2015
3	Abraj Al-Bait Towers	Mecca	Saudi Arabia	601	1,971	120	2012
4	Ping An Finance Center	Shenzhen	China	599	1,965	115	2016
5	Goldin Finance 117	Tianjin	China	596.6	1,957	128	2019
6	Lotte World Tower	Seoul	South Korea	555.7	1,823	123	2016
7	One World Trade Center	New York City	United States	546.2	1,792	104	2014
8	Guangzhou CTF Finance Centre	Guangzhou	China	530	1,739	111	2016
8	Tianjin CTF Finance Centre	Tianjin	China	530	1,739	98	2018
10	China Zun	Beijing	China	528	1,732	108	2018

### Technology description

#### 1) Super-light rope technology

Super-light rope technology with a carbon fiber core and high friction coating is used. Higher the building, the greater are the benefits. This special rope sets a new benchmark for high-rise buildings. It provides unrivalled elevator eco-efficiency, reliability and durability, while also improving elevator performance. In the future, it can enable travel heights of up to 1,000 meters.

It eliminates the disadvantages of existing steel ropes – high energy consumption, rope stretch, large moving masses, and downtime caused by building sway. Ultra-light and durable rope that offers huge advantages over the steel ropes traditionally used to hoist elevators

#### Benefits include:

- 2 x longer lifetime, tested under extreme conditions
- 60% reduction in moving mass, enabling much higher travel
- 15% less energy consumed
- Less sensitive to building sway
- Third-party approved

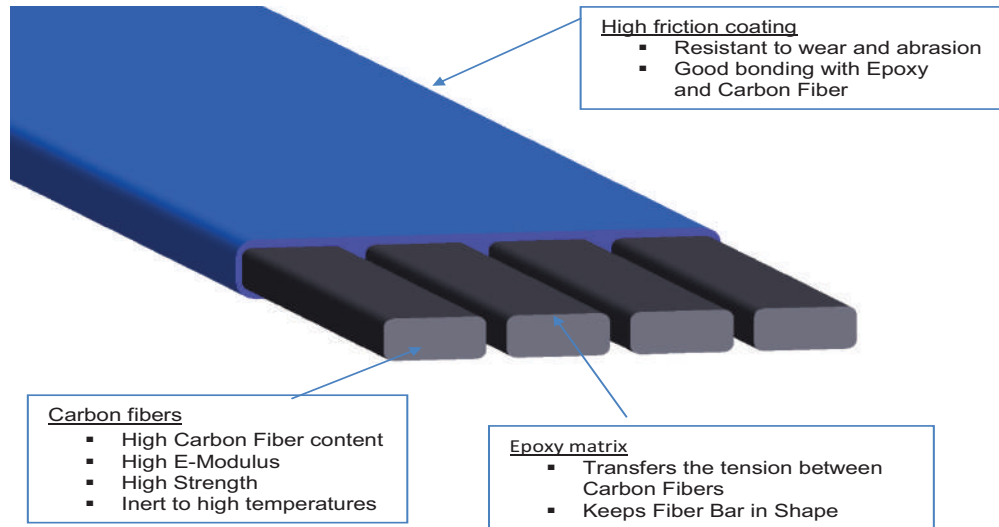

## 2) Advanced People Flow Solutions

**A. Destination Control System (DCS):** Destination control system optimizes the operation of the elevator system based on the selected destination floors and the number of waiting passengers. The system significantly improves the performance of the elevator system and provides more comfort for users –shorter journey times, enhanced security with visual guidance, more space. DCS helps in improving the handling capacity in high rise buildings. The benefits are stated as under;

- Shorter travel time and reduced full-stop points
- Clear guidance and timely information sharing and effortless navigation
- Avoidance of cross flows
- Quick and secure access and real time performance monitoring
- Prevention of congestion

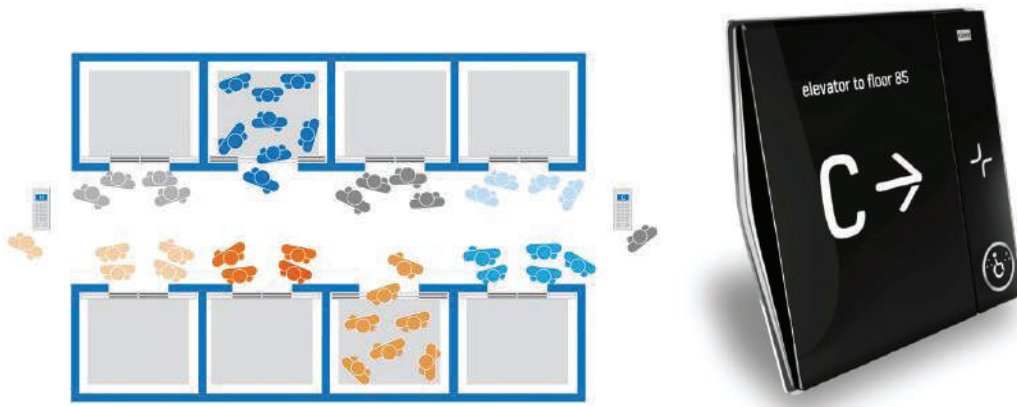

### Turnstiles with Access Control:

- Turnstiles typically located in the lobby area can be integrated with the DCS.
- When a passenger swipes an access card at a turnstile, an elevator is called to take them to a pre-defined destination floor.
- The user's allocated elevator can be shown on the turnstile display.



### A. Shaft Design Concept:

Some of the suggested solutions are as under:

- Avoid single shafts
- Provide Air Relief Vents in Shaft Walls of calculated size & spacing.
- Stack Effect is the movement of air in & out of the building. Thermal difference & moisture cause buoyancy. Greater the thermal difference & height of the building, higher is the buoyant force. Stack Effect needs to be controlled especially in fire situation. Lift lobbies need to be sealed & lifts parked with doors closed to minimize stack effect.
- Seismic Sensor provided in the Lift Pit. It senses primary wave and the lift controller puts the lift into the seismic mode. The seismic mode operation rescues people to nearest possible floor.
- The elevators in high rise buildings while moving at a minimum speed of 2.0 mps work as power generating equipment during deceleration, full load down & empty up conditions. This Regenerated Energy can be about 30 – 40 % of the energy consumption, thus there is that much power saving in case the power generated is captured and utilized within the building premises. Without regenerating module this energy is burned in resistors heating the machine room & further adding to air conditioning costs.

## **Benefits**

- Higher single flights as less number of transfer floors.
- Reduced construction cost and operating costs.
- Better handling capacity and lower time to destination.
- Synchronized transition due to integration of access control system and elevators.
- Reduced noise levels even at higher speed of travel.

## **Conclusion**

With shaft planning and use of the advanced technological solutions the above stated benefits can be achieved that enhance the people flow experience and optimize operating costs.

## **References**

**Kone R&D**

# TOWARDS SUPER TALL BUILDINGS

**Er. Vinay Gupta**, Director & CEO, Tandon Consultants Pvt Ltd

## Affiliations

After completing his Civil Engineering from BITS, Pilani, India in 1983 Er Vinay Gupta has served Span Consultants Pvt Ltd and STUP Consultants Ltd before joining Tandon Consultants Pvt Ltd, India in 1987, where he is serving as CEO. Er Gupta, has been involved in planning, designing and coordination of design, detailing and tender preparation of various bridges, flyovers, vehicular underpasses, long span and tall buildings, steel structures, chimneys and quality control documents. Some of the highlights of his carrier include design & planning of prestressed structures in India and abroad. 102m span Balanced Cantilever construction prestressed bridges with 70m tall piers of the famous Jammu Udhampur Rail Link (JURL) for first time in Indian Railways, Delhi Gurgaon Elevated Expressway, involving largest no of 1800 Pretensioned Prestressed Girders for the BOT project of NHAI, 500M long Prestressed Segmental Canntilever Construction Superstructure incorporating STUs and Dry Jointed Precast Segmental Prestressed Superstructures of 26km long LRT Metro in Malaysia are some of the pioneering structures, designed by him. He is an active member of various Codes and Standards Committees of BIS and IRC in India dealing with Earthquake Engineering, Special Structures, Loads & Stresses, Concrete Bridges, Bearings & Expansion Joints etc. His contributions include preparation of IRC:SP:65-2005 (Design and Construction of Segmental Bridges) and IRC:SP:71-2006 (Design and Construction of Precast Pretensioned Girders for Bridges). He has been honored with awards for the best papers titled “Seismic Design and Construction of Radisson Hotel, New Delhi” and “Launching Systems for Segmental Bridges” both by IBC and “Prestressed Concrete Design Award-2013” by IEI (The Institution of Engineers, India). He has authored about 100 technical papers in civil engineering journals & conferences and has been lecturing as Guest Faculty in NITHE, CRRRI, CIDC, ISDA, DPC, etc. Er Gupta is the President of IIBE (Indian Institution of Bridge Engineers). He is also the President of ICI (Indian Concrete Institute).

## Preamble

The entire world is busy carrying out construction of a large number of projects that relate to infrastructure, real estate, power sector, industrial sector, etc. Needless to mention that civil construction is the first aspect of a project implementation that precedes functional installations. Large volumes of construction require an equated volume of cement production. Some 3 billion tonnes of cement produced world-wide produces 3.2 billion tonnes of CO<sub>2</sub> gas, leading to green house effect. Blending of cement is a technology used to cut down emission of CO<sub>2</sub>. It also results into conservation of the natural resource, i.e. Lime Stone.

When it comes to tall structures, UHSC (Ultra High Strength Concrete) finds is important place. A building with 25 floors will have column size at lower levels as large as a regular room size. In such cases, it becomes prudent to go for High to Ultra High Strength Concrete with strength as high as 100 MPa,

significantly reducing the column sizes to provide adequate usable space. Usually, reinforcement quantity is as high as 4% at lower levels for overall economy. Alternatively, steel columns, encased in concrete, are used for the size control. The lifts associated with such buildings run at very high speeds, say 5m/sec to 15m/sec to stop at discrete floors and slower speed lifts for nearby floor coverage. Some of the world's tall/super tall buildings are depicted in Fig 1.

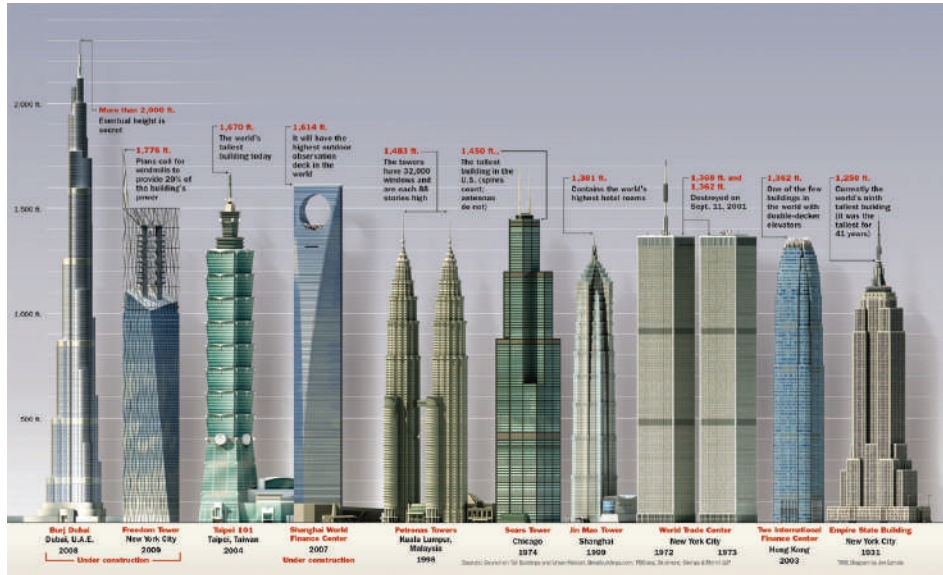

Fig 1. World's Tall Buildings

Some of the challenges associated with tall buildings are as follows:

1. Associated wind and seismic forces
2. Expansion joint movement
3. Pumping concrete to those heights during construction, etc.
4. Excessive vibrations
5. Large capacity pile foundations
6. Construction of structure
7. Cleaning of façade
8. Pumping water to those heights
9. Fire control

### A Amari Atrium Hotel, Bangkok

While it is important to conserve the environment, it is also equally important to speedily complete the projects, which apart from having financial benefits, also reduces disturbance to traffic and the neighboring areas. 25 storied Amari Atrium Hotel, Bangkok, built in the year 1991-93, incorporates

prestressed floor slabs for the 20 nos guest room floors. With the advent of prestressing, each floor could be completed in an average of 9 days per floor as against a usually expected speed of one to two months per floor. See Fig. 2 for overall view of the building.



Fig 2: Amari Atrium Hotel, Bangkok

The structural system comprises Banded Slab System with frames at 8.2m spacing. Each frame comprises 12m centre to centre span between columns flanked by 4m cantilever on either side. Prestressed Band Beams are 400mm deep, that span 12m from column to column and 4m cantilever, on either side. The Prestressed slab, that spans 8.2m, has a thickness of 200mm. Prestressing system comprises unbounded tendons using grease coated factory extruded strands, housed in flat prestressing ducts for post tensioning the slab. See Figs. 3 & 4 for prestressing system. Apart from speed of construction, prestressing gave a distinct advantage of reduced structural depth, reduced deflections, enhanced durability and reduced consumption of concrete, eventually leading to sustainable construction.



Fig 3: Prestressed Banded Slabs

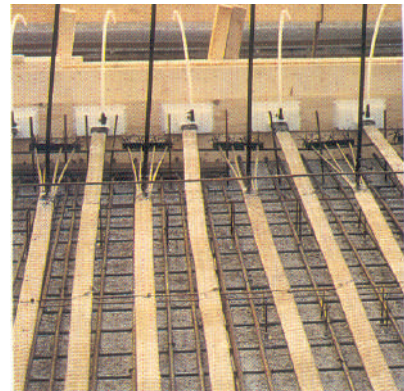

Fig 4: Flat Prestressing Cables

## B. Petronas Twin Tower, Malaysia

The 357m tall twin tower comprises 110 no floors in each of the two towers. The structure held a world record, when constructed in 1998 (see Fig. 5). The two towers are interconnected at 45<sup>th</sup> level. In order to control the column sizes, designers chose to use C110 concrete (nearly half the strength of steel). The structural system comprises concrete core (23m×23m) and concrete peripheral columns.



Fig 5: View of Petronas Twin Tower, Malaysia

## c. 275M Tall Chimneys

India has been striving to alleviate the electric power crisis, recently aggravated due to the economic boom in the country. Out of the two major sources of power, i.e. Hydel Power and Thermal Power, the latter has become more popular due to its adaptability towards larger production capability. Thermal power is obtained through burning coal, which is required to operate the steam boilers. When burnt, the coal produces polluting gases that need to be discharged at an elevation high enough to dilute the pollution and to keep it within acceptable limits at ground level. An adequately designed tall chimney serves this purpose. As the pollution norms have become stringent with time, the chimney heights have gone up progressively from 100m to 150m to 220m to 275m. This is represented well in the chimneys designed over the years by the authors, Fig. 6 In most thermal power plants, 275m tall concrete chimneys have now become the standard norm. It may be worthwhile mentioning here that a bi-product of burning of coal is fly ash, which is produced in the process line between boiler and chimney. This fly ash is extracted using electrostatic precipitators, which incidentally can be used in blended cement and as mineral admixture in concrete. Figures 7 and 8 depict some of the recent chimneys designed by the author.

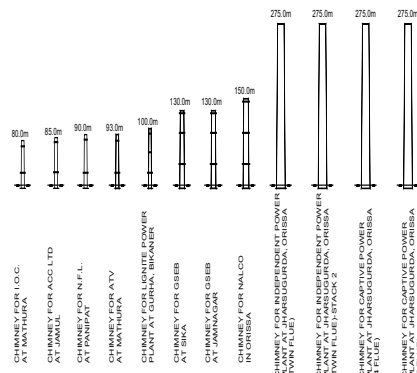

Fig 6: Recent Tall Chimneys of India



Fig 7: ATV Chimney at Mathura



Fig 8: GSEB Chimney at Sika, Gujarat

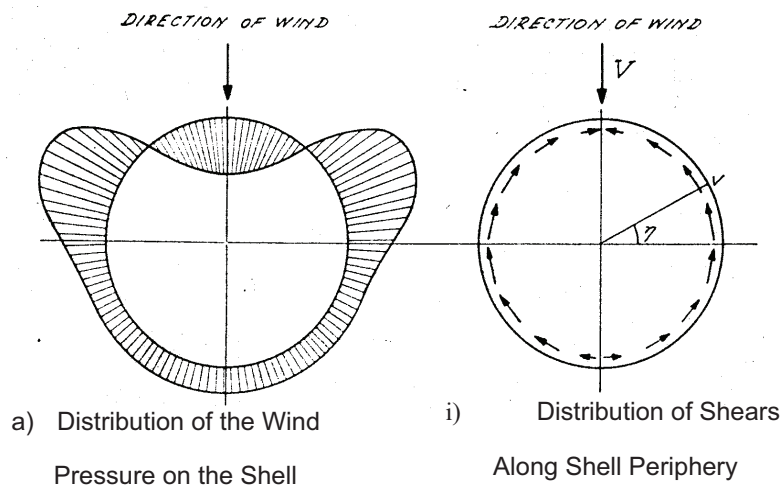

**Fig. 9: Evaluation of Wind Forces Produced by Ovaling Moments**

**C.1 Wind Effects**

*Global Effects*

The Global Wind effects invariably govern the dimensioning of the structure. For estimation of the wind speed/pressure at the location, IS:875 (Part 3), is used. Both the “3-sec Gust Wind” as well as “Mean-Hourly wind” is determined for arriving at the design forces.

**Wind Forces:**

The 3-sec gust wind is determined by the following formula for evaluating wind speed at height: Z :

$$V_z = V_b K_1 K_2 K_3 \text{-----} (1)$$

here,  $K_1$  = Probability factor. The mean probable design life of the structure is usually taken as:

25 years for shell alone condition;

100 years for completed chimney condition

$K_2$  = Terrain category factor depending on the roughness of the terrain which is in turn dependant on the height of obstacles (buildings, trees, etc) of the surrounds

$K_3$  = Topography factor which depends upon features like existence of valleys, ridges, cliffs, etc in the vicinity.

The mean hourly wind is again arrived at using as follows:-

$$V_z = V_b \times K_1 K_2' K_3 \text{ ----- (2)}$$

Here,  $K_1$  and  $K_3$  shall be as defined equation (1)

$K_2'$  depends on the terrain category as indicated in the code for various terrain categories.

The wind pressure at any height Z can be calculated from the following equation with the dimensions N/mm<sup>2</sup>; using equation (1) or (2) as the case may be:

$$P_z = 0.60 V_z^2 \text{ ----- (3)}$$

The peculiarity of the chimney structure is that it has a response which can be categorized in two lateral directions and evaluated separately. The first is called “Along Wind” and the second as “Across Wind” (perpendicular to the wind direction). They correspond to the so-called “drag” and “lift” force coefficients as understood in fluid dynamics.

**Along Wind:**

The “Along Wind” effects are first determined from static wind force (N/mm) using the 3 sec wind at any height Z as follows:

$$F_z = 0.60 C_D D_z V_z^2 \text{ ----- (4)}$$

Where  $C_D$  = Drag coefficient, taken conservatively as 0.8 for circular structures

$D_z$  = Diameter of chimney at height Z

$V_z$  = as defined in equation (1)

The “Along Wind” effects are additionally calculated by the Gust Factor Approach using the mean hourly wind which takes account of the turbulent characteristics of the wind as well as the natural frequency of the structure, as explained well in **IS:4998 (Part 1)**, by the following formulation:

$$F_z = F_{zm} + F_{zf} \text{ ----- (5)}$$

Where  $F_{zm}$  is the wind load in N/mm due to the mean-hourly wind pressure, while  $F_{zf}$  is due to the fluctuating component of the wind force at the same height.

The “Along Wind” effects are taken as the more severe of those determined from equations (4) and (5).

### Across Wind:

The “Across Wind” response of chimney corresponding to the “lift” force coefficient is caused by the phenomenon termed as “Vortex Shedding”, Fig 10.

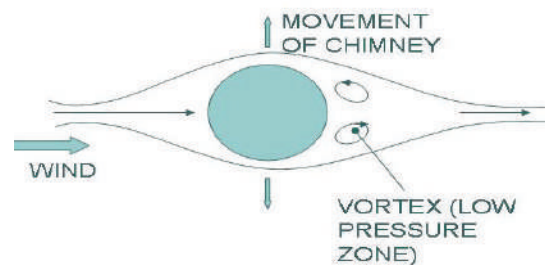

Fig. 10 Across Wind Effects

Depending on the dimensions, surface roughness and dynamic characteristics of the chimney, “vortices” are formed as the wind flows past it.

The air flow pattern around circular objects result in force coefficients which vary with the Reynold’s number ( $R_e$ ), which, as we know is proportional to the wind velocity multiplied by the diameter. At sub-critical Reynold’s numbers, when wind speed is not very high, frequency of Vortex Shedding can come in resonance with that of the chimney, resulting in high amplitude across wind vibrations that could reach high proportions.

In the design of the chimney first the critical wind speed  $V_{cri}$  is determined at which the Vortex Shedding can “lock-into” the across wind oscillations. This critical wind speed is given by

$$V_{cri} = f_i d / S_n \text{ ----- (6)}$$

Where  $f_i$  is the frequency of the chimney for the  $i$  th mode of vibration,

$d$  = effective outer diameter of chimney at 5/6 height from base

$S_n$  = Strouhal number, taken as 0.2

Generally, the first two modes of vibration are adequate for such computations.

If the value of  $V_{cri}$  is such that it can not occur at the site, i.e., it is higher than the steady wind speed calculated by equation (2), then no further considerations are required for Across Wind response.

The lateral force  $F_z$  on the chimney for Across Wind response follow the procedure given in the code, which look complex but in fact are fairly simple, being based on the work of Vickery and Basu.

**Aerodynamic Interference:**

In case there is a tall object (chimney, silo etc) in the vicinity of the chimney in question, it may cause “buffeting” leading to additional disturbance or magnification called Aerodynamic Interference Effects, See Fig 11.

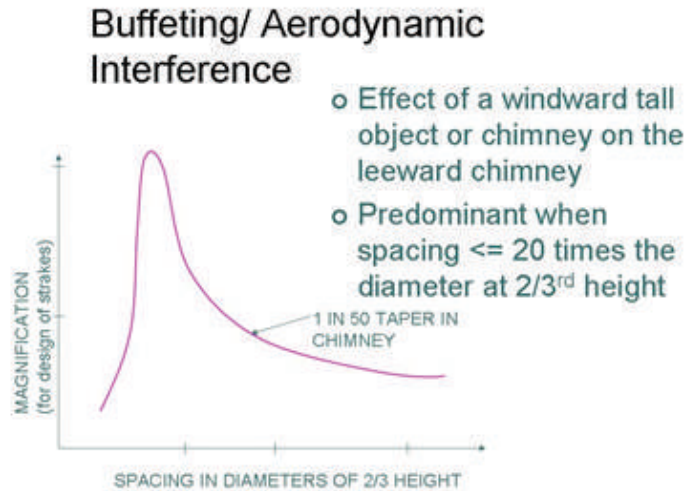

Fig. 11 Interference Effects of Aerodynamic Wind

**C.2 Earthquake Effects**

India is divided into four Seismic Zones as elaborated in IS:1893 Part 1. The horizontal seismic coefficient for Design Basis Earthquake is given by

$$A_h = \frac{(Z/2)(Sa/g)}{R/I} \text{ ----- (7)}$$

Here Z = Zone Factor depending on the location of project in India

I = Importance Factor, taken as 1.5 for Reinforced Concrete Chimneys

R = Response Reduction Factor taken as 3

Sa/g = Spectral acceleration for 5% damping and as a function of period of vibration and sub-strata below the foundation.

Dynamic analysis using response spectrum method is generally recommended for tall structures in consonance with equation (7). The no. of modes to be considered in the analysis should be such that about 90% of the modal mass is excited. The modes are then combined for response (shear, moment, etc.) as suggested.

### C.3 Slip-forming of Chimney Shaft

Chimney shell is either constant in diameter or as is more common tapered. Construction is either done using Slipforming (which is more common) or Jump Forms. Slipforming is illustrated in Figs 12, 13 & 14. slipforming requires placement of jack rods at 1.0m to 2.0m spacing along the shell to support and raise the shuttering and working platforms. The concreting in this case is a continuous process, without construction joints. During slipforming the projecting reinforcement dowels for corbels and platforms need to be tackled. A better solution is to provide reinforcement couplers at these locations, with internally threaded sleeves left inside the shell during slipforming.

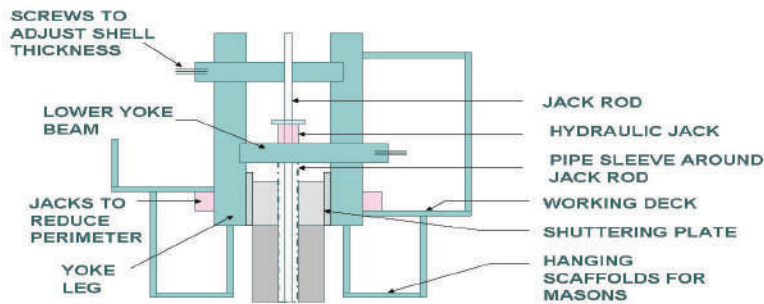
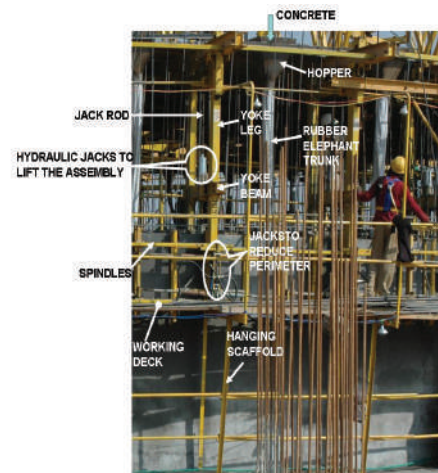

Fig. 12: Slip Forming Equipment



Fig. 13 Slip Forming in Progress



wFig. 14 Slip Forming Equipment

### D. Structural Framing

Scientists have tried various types of structural frames to efficiently take care of high seismicity and wind induced forces in high rise buildings. Some of them include peripheral tube with internal core as in Fig 15, peripheral tube with internal shear wall core apart from regular moment resisting frame as in Fig 16. In case of bigger requirement of shear wall in a particular direction, coupled shear wall is provided

as in Fig 17. There can be a system where shear wall with outrigger belt system is provided in one direction and regular moment resisting frame in the other as in Fig 18.

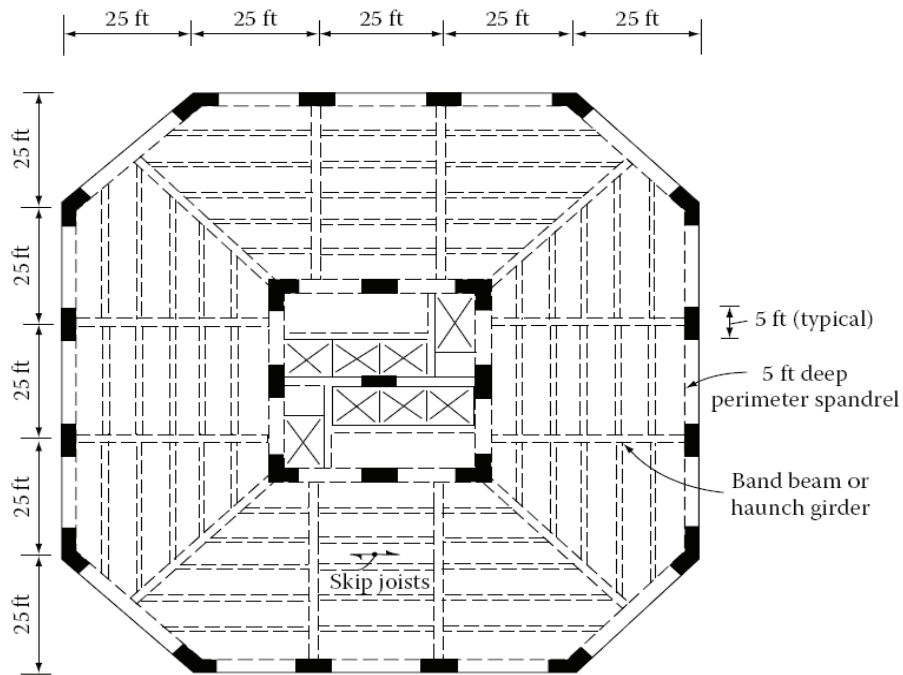

FIGURE 3.12 Tube building with widely spaced perimeter columns.

Fig. 15: Peripheral Tube with Internal Core

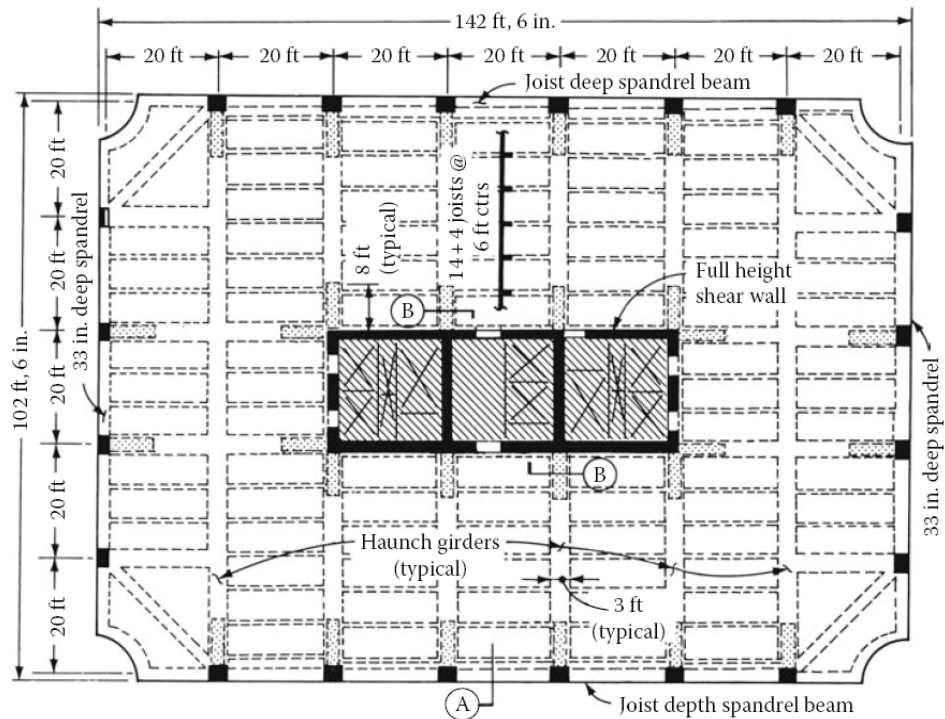

FIGURE 3.13 Typical floor framing plan: Haunch girder scheme.

Fig. 16: Peripheral Tube with Internal Shear Wall Core

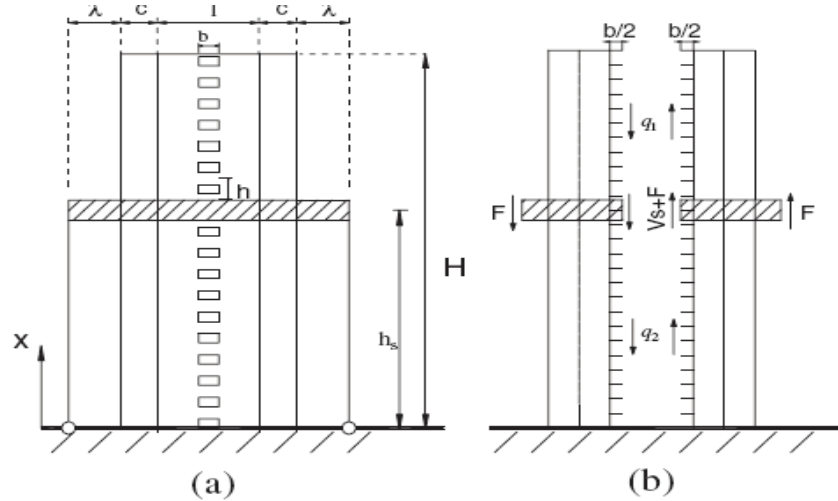

Fig. 14: Coupled Shear Walls Stiffened by Outrigger and belt wall:

- (a) General Arrangement
- (b) Force Transfer

Fig. 17: Coupled Shear Walls Stiffened By Outrigger and Belt Wall:

- (a) General Arrangement
- (b) Force Transfer

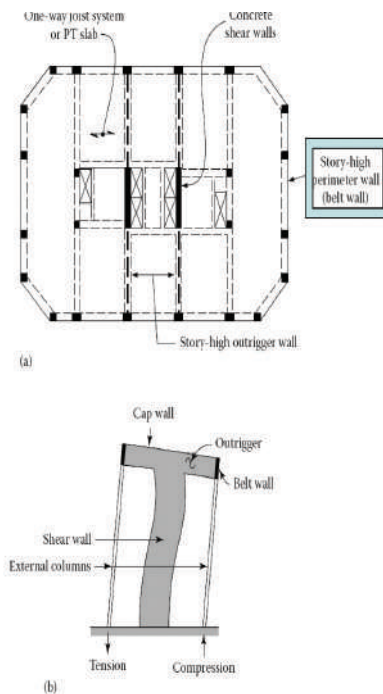

Fig. 18: Outrigger Belt system in one Direction and Moment Resisting Frame in the Other

While deciding structural framing of a multistoreyed building, the shear walls should be placed in the middle. Placing them on the outer sides in the direction of larger stiffness can induce unduly large internal forces in the floor structure due to thermal shrinkage and creep movements.

## E. Challenges in Tall Buildings

Wind and seismic forces are high in tall buildings, which need to be accounted for, adequately. Several structural systems are used in tall buildings depending upon the height of the structure. In tall buildings, wind starts governing over seismic forces for the reason that wind forces are more in the flexible structures with larger Natural Time Period. Converse of this phenomena applies in case of seismic forces.

Expansion joint opening depends on movements due to lateral forces, apart from temperature, shrinkage and creep. Out of phase movements of the adjoining building blocks due to seismic and wind forces is a crucial factor in deciding width of the expansion gap. Hence, for tall buildings, movements are much larger than those in shorter buildings. Movements calculated for an eight storeyed RCC building in seismic zone IV are calculated as follows:

A thermal strain of  $11.7 \times 10^{-6}$  m/m/ $^{\circ}$ C and shrinkage strain of  $3 \times 10^{-4}$  m/m have been used. The value of modulus of elasticity of concrete  $E_c$  has been taken as instantaneous one for seismic effects, and vertical loads. Typically, the movements for the 8-storeyed structure, are calculated as follows:

SNo.	Phenomenon	Movement at Ground level	Movement at Roof Level
1.	Seismic out of phase	$\pm 2.5 \times 2 = \pm 5\text{mm}$	$\pm 24 \times 2 = \pm 48\text{mm}$
2.	Thermal	$\pm 2.9 \times 2 = \pm 5.8\text{mm}$	$\pm 3.6 \times 2 = \pm 7.2\text{mm}$
3.	Shrinkage	$+ 2 \times 2 = +4 \text{ mm}$	$+ 2.5 \times 2 = +5\text{mm}$
4.	Vertical loads	$- 0.15 \times 2 = -0.3\text{mm}$	$- 2.5 \times 2 = -5\text{mm}$

wherein + denotes contracting movement and - denotes expansive movement. Therefore, the movement gap is calculated as  $48 + 7.2 + 5 = 60.2\text{mm}$  at roof level and  $5 + 5.8 + 0.3 = 11.1\text{mm}$  at ground floor level. A movement gap of 50mm has been provided at all floors above GF and nominal gap of 25mm has been provided at basement and ground floor levels in order to optimise on the expansion joint material. Width of movement gap above ground floor has been reduced from the calculated value of 60.2mm to 50mm owing to the fact that actual seismic movements are less than calculated due to the presence of brick walls, which increase rigidity of the structure. Movement at basement and ground floors also gets restricted by the retaining walls acting as rigid elements.

Pumping of concrete during construction requires make up pumps at intermediate levels. This requires comparatively higher slump of concrete as 100mm slump is not enough for such heights.

Usually, lift shafts and shear walls are constructed using Slip-forming (similar to chimneys) or Jump-forming technique, in order to hasten up the process. Since, the lift shaft has to support the tower crane for construction, the lift shaft is maintained sufficiently above the floor being constructed.

A pertinent problem faced in tall buildings is excessive vibrations, especially, in top floors causing discomfort and nausea feeling to the occupants. For this purpose, amplitude of vibration needs to be controlled. Alternatively, Seismic Base Isolators should be provided in order to reduce amplitude of the vibrations.

Usually foundation type associated with tall structures is pile or piled raft. In the case of 25 storied Amari Atrium hotel, Bangkok, pile is as large as 1.5m dia with 60m depth, mainly in order to terminate at the second sand layer band available in Bangkok.

Similarly, for obvious reasons, cleaning of the façade (often glass) is a challenge. A tyre mounted vehicle with hanging cradle and adequate counter weight moves at the roof level. The height of cradle is adjusted with the help of winch & pulley. In case of super tall buildings, high winds at those levels can hinder the cleaning operation.

Similarly, pumping of water to such heights requires high capacity pumps and electric energy.

Fire fighting is one of the major issues involved in tall buildings. And, without the permission of the fire department, a tall building is not permitted to be constructed. Fire department needs to augment itself to serve such large heights in case a fire.

### F. Tall Buildings in and around Delhi

A 26 storey building, Vikas Minar was constructed over 40 years ago for housing the offices of DDA in Delhi (see Fig. 19). Similarly, a twin tower complex of SCOPE was constructed in mid-eighties in Delhi. One tower has 20 floor and the other 25 (Fig. 20). It is interesting to note that the two towers which are curved in plan were arranged opposite to what is shown in Fig 20 during the initial planning. However, Wind Tunnel Study revealed highly enhanced wind pressures due to a ventury like effect. Hence, the orientation of the two towers had to be reversed to the one shown in Fig. 20. Several residential and commercial buildings of similar height exist and are under construction in Gurgaon. Another tall building complex under construction is Supernova in Noida (see Figs. 21 & 22).



**Fig. 19: Vikas Minar, Delhi**



**Fig. 20: SCOPE Twin Tower, Delhi**



Fig. 21: Supernove Complex, Noida

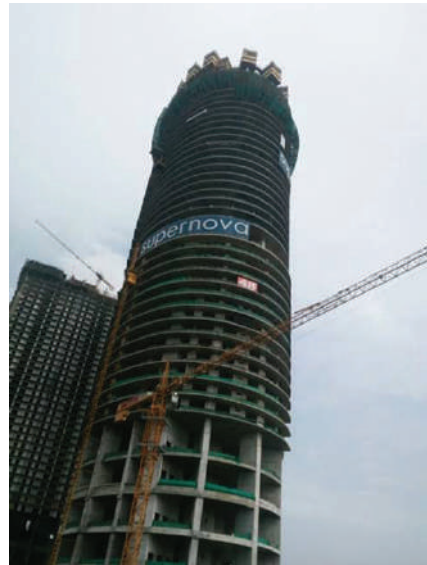

Fig. 22: 60 Storeyed Supernove Tower

### G. Special Seismic Devices

Some of the special devices to control the lateral forces are as follows:

1. Base Isolation
2. Friction Pendulum Damper
3. Tuned Mass Damper

All the above are termed in the category of passive devices. Base Isolator comprises low Damping Rubber (LDR), High Damping Rubber (HDR) or Lead Rubber Bearing (LRB) depending upon the required damping and later force reduction. Damping related of these devices is 5% to 6%, 10% to 20% and 30% respectively. Refer Fig. 23 for typical rubber based Base Isolation Devices.



Fig. 23: Base Isolation Devices

Friction Pendulum Dampers work by dissipating energy through friction and potential energy concept, see Fig. 24.

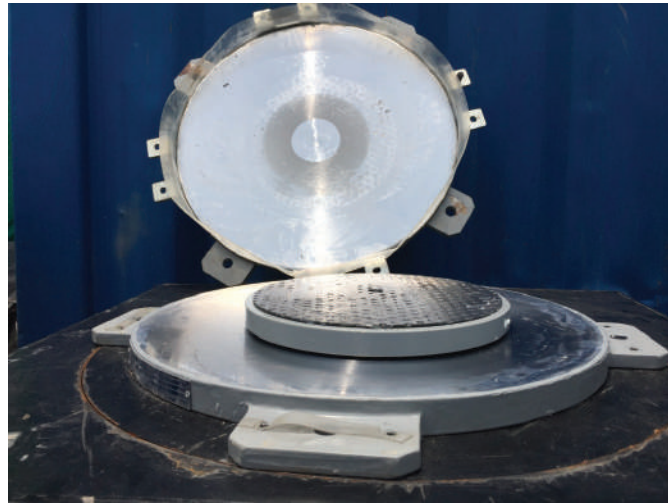

Fig. 24: Friction Pendulum Damper

While the above two types are placed at bottom of the building, above foundations, Tuned Mass Damper is placed towards top of the building. It comprises mass (0.25% to 0.7% of total building mass), spring and damper attached to the structure in order to reduce dynamic response of it. Frequency of the damper is tuned to a particular structural frequency so that when the frequency is excited, the damper will resonate out of phase with the structural motion, see Fig. 25 for illustration.

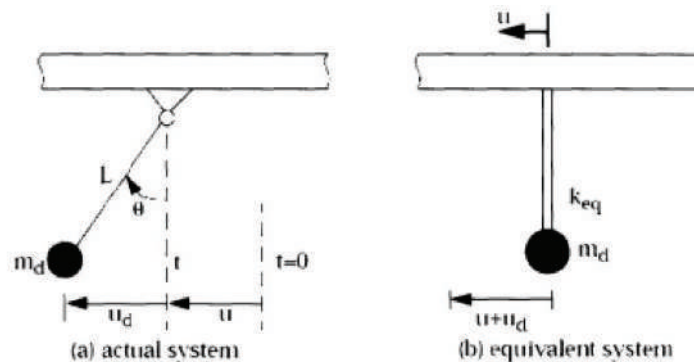

Fig. 25: Tuned Mass Damper

## CLOSURE

Tall buildings have different challenges to take care of. Non Structural challenges include fire fighting, facade cleaning etc. Structural challenges include structural framing, type of foundations, alleviating lateral forces, construction issues, etc. Once, a careful planning of these aspects is done, problem of land space associated with rapidly developing mega cities can be substantially solved.

# **AIRBORNE DISEASE SPREAD IN HIGH RISE BUILDINGS DUE TO RELIANCE ON MECHANICAL VENTILATION: A REVIEW**

**Ar. Raja Singh**, Research Scholar, School of Planning and Architecture, New Delhi

&

**Prof. Dr. Anil Dewan**, Professor and Research Supervisor,  
School of Planning and Architecture, New Delhi.

## **Abstract:**

In India, there is a huge burden of disease especially infectious disease which causes fatalities on a large scale. Tuberculosis, SARS, Influenza, Nipah and other diseases have been major killers in India at a large scale or a sporadic scale. One thing common is that these are spread through the airborne route of infection spread. In the recent past, there has been an increasing trend of High Rise Buildings in India. These buildings, with an increase in the floors, create a high pressure situation on the higher floors of the building. At such high floors, there is a higher discomfort possible due to high wind velocities and wind pressure overall. This high pressure may force the building designers to have non-controllable window panes which remain fixed. With that, they may provide only mechanical ventilation and close the channels for natural ventilation. When such mechanical ventilation exists, there is a greater chance of airborne infection spread in such buildings. In one case of SARS outbreak in Hong Kong, there was disease spread in a hotel which was mechanically ventilated. This is due to the fact that the air conditioning system of a residential building or a hotel may not be designed like the one in a hospital, with filtration and germicidal systems. Hence, while building High rise buildings with mechanical ventilation and fixed window panes, the designers must be made aware of a chance of disease spread and possible remedial measures for the same. This paper aims at reviewing the literature available creating a correlation between disease spread in high rise buildings and how we as architects, engineers and designers can create undo any negative possibility. This paper creates a starting point for creating awareness and identifying the possible gaps that may be possible in this area of research and practice.

## **Keywords:**

**Airborne Disease Spread; High Rise Buildings; Disease spread in Buildings.**

## **Introduction:**

There is a growing focus on building High Rise Buildings in Urban Centres across the world. <sup>1</sup> This is due to the very pertinent need on increasing the density of the metropolitan cities in order to cater to a high urbanization and urban population boom. In India, any building more than 15m in height is classified as High Rise. Across the world there are buildings way higher than 15m and are in the league of skyscrapers. These buildings are full-fledged townships in themselves with independent services built into them. As there is a clear consensus across the world in the increase of the high rise buildings, their rise and growth in number is seemingly inevitable. This paper is an attempt to look into the threat of Disease spread in these high rise buildings by the airborne route.

## **Airborne Infection Spread in Buildings**

There is a branch of engineering called aerobiology which deals with the bio aerosols. One example of bio aerosol is the sneeze that a person emits<sup>2</sup>. This suspension of droplets in the air has the potential to remain airborne for a time long enough to infect another human being. This mechanism has been used by the Mycobacterium tuberculosis for centuries to remain a potent threat. As soon as it infects one person, it looks for an outlet to spread and this is through the airborne sneeze route. By this mechanism, the tuberculosis bacteria have been able to keep itself in the human species for millennia. This is its very potent mechanism of survival. Buildings play a key role in this infection spread as they create zones with limited dilution ventilation.

## **Ventilation and Disease spread in Buildings**

The Outdoor air and sunlight has germicidal properties. When we allow the outdoor air to enter the spaces, it replaces the indoor air and this phenomenon is measured by the term: ACH or Air Changes per Hour. It has been suggested by the National Building Code as well as many WHO guidelines that there has to be a certain minimum Air Changes per Hour. These air changes per hour have been found to be very appropriate in studies done in Peru where Natural Ventilated spaces clearly provided high ACH rates as compared to the mechanically ventilated spaces of the same configuration. This is possible by the principle of Dilution Ventilation which has been at play in such buildings.

## **High Rise Buildings: Exclusive Case**

The high rise buildings are an exclusive case as they cannot be provided with a full natural ventilation due to the high wind pressure prevalent at the higher floors of the buildings. Such high wind flow can be of discomfort to humans. Hence, the building designers and architects have to resort to isolating the building interior from the outside and providing mechanical ventilation necessarily. This leads to design choices where the window panes are fixed and have no manual control by the inhabitants. One such method is the fixed glass curtain wall.

---

<sup>1</sup> Guedes M.C., Cantuária G. (2017) The Increasing Demand on High-Rise Buildings and Their History. In: Sayigh A. (eds) Sustainable High Rise Buildings in Urban Zones. Springer, Cham

<sup>2</sup>

## **The Curtain Wall and the Spread of Diseases.**

Research has shown that curtain walls are attached to the floor plate with metal fittings and they are not always sealed, hence creating a continuous space from the top to the bottom of the buildings where easy air exchanges may take place. This has been identified as a major fire spread gateway in the high rise buildings. The fire spreads due to absence of the compartmentalization which normal buildings (without curtain façade walls) exhibit. This creates a continuous air spread zone throughout the building and there is no compartments formed. This same principle of fire spread holds good for disease spread as the air in one floor may spread to other floors due to the principle of air buoyancy and stack or gravity. This spreading can be a cause of spread of airborne diseases in these buildings.

### **Mechanical Ventilation Systems: The Inherent Flaw.**

Even if we achieve a building with the floors that are fully compartmentalized, there are other mechanisms at play in Disease Spread. The Air Conditioning Systems rely on filtration systems to filter out the airborne particles. The size of a typical virus is 0.02 micron and that of a bacteria is 0.2 micron. For such sizes we need HEPA filters of very high efficiency. These are the type of filters used in hospital buildings and research labs. These filters too have different ratings of possible filtration. The cost of such filters is very expensive and require constant maintenance. Even if the filter is functional, it may harbor bacteria and virus which may be released if not cleaned form time to time. The cause of Serratia mercenses disease in a baby hospital in UAE was attributed to air-conditioning filter. Another possible cause of concern can be the need for fresh air supply into the air conditioning system. There are different guidelines for different spaces and most prescribe a rate of fresh air intake into the air conditioning systems. The only problem is that with residential buildings, these rates of fresh air intake may not be as stringent as the case of hospital wards though the chance of disease spread may still be possible. This is due to the fact that the skyscrapers like Burj Khalifa are full townships with independent spaces but shared air due to the mechanical system.

### **Threat of Biological Warfare linked to Building Ventilation**

Another area of key concern is the intentional spread of bio warfare agents like bacteria and virus into the air conditioning systems which can spread throughout the buildings in a short span of time. This can expose the inhabitants of the buildings to diseases like Anthrax, Smallpox and other Bio warfare weapons and cause fatalities. A building designed to cater to the prevention of spread of these bio warfare agents will also by default serve as a building where the infection will not spread due to unintentional release.

### **Green buildings and Ventilation**

The rise in the energy efficient green buildings is a good sign for the energy scenario of the country. This green energy movement started as a reaction to the 1973 Oil Embargo where the western world was in an energy crisis due to oil supply being hit. This led to an interest in buildings which consume lesser energy as building insustry is a major energy guzzler and any decrease in building energy demand will decrease the energy demand of the whole country. As more energy efficient buildings were

being created, the zones of the building decreased in volumes in order to increase the efficiency of the space to conserve the energy. Buildings were also tightly sealed to decrease energy losses and hence led to decreasing levels of fresh air being supplied to the buildings. The use of a typical Split air conditioner system in a sealed room means that there is no air exchange and the same air is being re circulated over and over. Hence, the energy efficient buildings were later blamed to cause the Sick Building Syndrome and have also been investigated to be a cause of airborne disease spread.

## **Conclusion**

In conclusion, there is a key concern of disease spread in the high rise buildings due to their compulsory mechanical ventilation due to the high wind pressure at higher floors. This concern has to be spread in the communities of architects, engineers, buildings professionals and the regulatory bodies so that this can be actively resolved. The building professionals have the responsibility to cater to this concern in their design from the inception stage as part of the integrated design approach prescribed by the National Building Code. Researchers in research institutes should also consider this as a research gap to further the cause of safe and sustainable buildings.

# HIGH-RISES – EM-TOWERING INDIAN ARCHITECTURE

Ar. Rajeev Singhal & Ar. Mitu Mathur, Gian P Mathur & Associates

India cities are witnessing immense pressure due to Rapid urbanization owing to mass migration from rural areas, especially during the last decade. The urban population of India increased from 26% (217 million) in 1991 to 31% (377 million) in 2011, and projected to reach 40% (600 million) by 2031. Its need of the hour to act upon the upcoming crisis and revolutionize our ways of addressing this Urban Expansion. The Western approach of suburbanization and horizontal expansion which results in Urban Sprawl is gradually eating away our croplands, affecting the farmlands and thereby encouraging a vicious cycle of migration to urban lands. In retrospect, the new Indian urban landscape, which is being designed around grand concepts such as smart cities and export-oriented industrial corridors, needs to adopt vertical expansion as an overarching strategy while promoting high-rise communities for sustainable habitats, in our desire to be global and modernized.

## Vertical cities: A sustainable response to burgeoning Indian cities

High-rise structures can enable vertical growth of the cities and have the potential to decongest core city areas while mitigating urban sprawl. We are fortunate that since 2014 our government has promoted the construction of high-rise structures in the country and has facilitated redevelopment and revitalization of its core city areas. Thereby, promoting High Rise construction and alleviating the ever increasing land costs and maximizing FSI on city's precious land bank.



## How high is High-Rise?

The definition of a high-rise as per National building code of India is a structure with four floors or more, 15 to 18 metres in height. Whereas, American National Fire protection Association defines it as being higher than 23 Metres, about 7 floors. With respect to current Indian context, 23 Metres is considered as comfortable in the construction industry in most parts of the country. But what our real estate sector is really eying at are buildings that are at least 100 metres in height in Metropolitan cities and around 50 Metres in progressive tier-2 cities. The time is ripe for construction industry to take a leap and refine its skills, expertise and technologies to escalate from building high-rises to skyscrapers, structures taller than 300 Metres.



## The Art & Science of going Higher

Tall buildings are towering achievements that have the power to define the skyline of a city. There needs to be a careful amalgamation of aesthetic appeal and scientific innovation to strike a stable-appealing urban form. As the towers need to look unique and sleek, they should be supported on a proportional base and strong foundation to ground it. Not only are the appearance, the engineering that secures the building from natural wind pressure and earthquake forces should be the primary concerns. Subsequently, optimizing the energy efficiency of the building and its users is an essential incorporation towards reducing its environmental footprint.

Since these building will accommodate more density, they will essentially emulate a vertical community, which should ideally combine a mix of uses like retail, office, communal spaces, recreational and residential. In Indian cities, parking is also a major consideration, which makes the coordination of mix of uses and parking in a vertical tower fundamental. The success of the design will depend on the efficacious integration of all functions with services and urban public transportation systems.

## Safety & Security in Design

**Architectural safety** of a high-rise building is crucial, with respect to its prevailing seismic zone and fire evacuation strategy. Structural safety standards defined by the codes are for minimum safety standards, whereas for high-rises the codes need to be further refined, to avail best global standards. The way an earthquake affects a 7 storey building is very different from how it does a 20 storey one; which definitely demand a fresh set of regulatory framework. Structural standards for Seismic zones IV and above for high-rises need to be specially formulated, with incorporation of new construction technologies adopted by the industry.

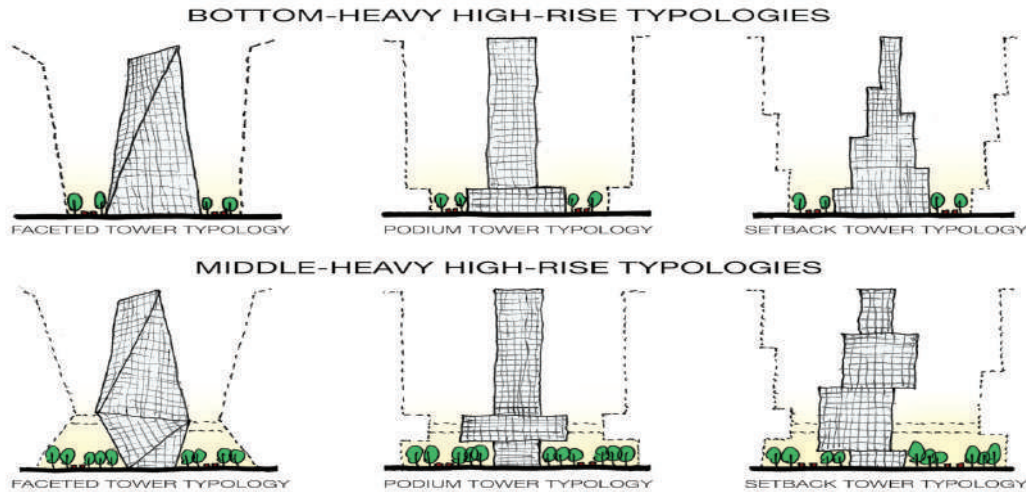

**Vertical circulation** has a critical role for efficient functioning of the buildings at the same time devising an evacuation strategy for residents in case of a disaster or emergency. Efficient design combinations should be formulated for enabling a user to escape the floor using at least 2 short, easy exit routes to reach the fire tower or refuge floor / terrace. A fire tower acts as the backbone of a high-rise structure, which needs to be carefully located both within the building and with respect to the site, for enabling access to fire tender and fire-fighting team. The staircases must be enclosed and pressurized, user friendly and of adequate width that should ideally be governed by the building height, number of users and not just the minimum standards of the byelaws. Refuge floors too can be creatively multi-purposed as recreational spaces that are much needed in a vertical living scenario.

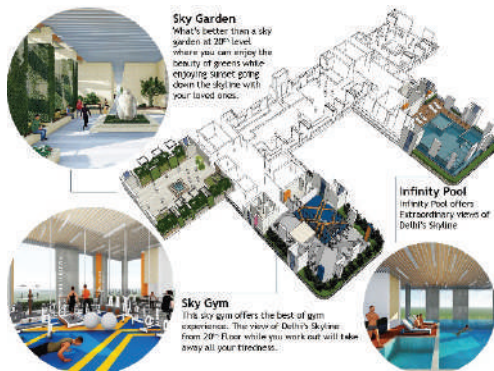

Consequently, equally important is Wind-Tunnel testing of the build fabric in the context, for efficient integration of wind pressure and wind loads in the structural and façade design; for ensuring pedestrian comfort on lower as well as upper floors and indoor ease and sense of security. Additionally, the façade should be designed for robustness, where materials selected should be able to withstand fire and higher wind load. Along with complex considerations of durability, energy efficiency, aesthetics and cost; these façade materials ought to be easy to install and maintain effectively for longevity of the building. Glass has played a major role in enabling both aesthetics and efficacy for high-rise structure, as it is lighter than concrete, reduces dead load on the structure and provides an advantage of beautiful views of the city. New ranges of high performance facades such as hermetically sealed double glazed systems, Quadra-core technology help maximize on daylight and keeping the interiors cool by reducing heat intake. Emerging technologies in climate responsive facades will also soon gear visibility in the near future, for both their aesthetic and functional appeal.



## Innovations in Construction Technology

While Indian architects and engineers are gearing up to design skyscrapers; the expertise in skill-set and use of modern technology play a critical role in executing these projects. Given the scale, the builders and contractors need to be proficient in planning of logistics, incorporating safety systems and ensuring finishing quality. The real challenge is of revolutionizing the construction methods to meet the targets while maintaining quality controls and safety standards. The last decade has witnessed introduction of **advanced technologies like system formworks, slip formworks and Pre-Fab construction that are now being adopted and constantly developed to ensure seamless execution.** System Formwork implies use of aluminum formwork for shuttering, that assures quality and speed required for tall buildings. Similarly, concrete industry has gone a long way to achieve concrete mixes that can be pumped to great heights, aided by high pressure pumps and other state of the art construction equipment such as **Boom Placers, Spider Boom Placers**, which are able to pump the concrete to greater heights with good flowability. High performance concretes are also becoming essential today for optimizing the cost and getting superior performance. Self-Compacting concrete is one advancement that has excellent deformability in the fresh state, high resistance to segregation that can be placed and

compacted under its self- weight without applying external compaction effort. While minimizing voids around embedded items, it produces high degree of homogeneity. **Dry wall construction techniques** also help achieve quality and speedy construction. In times to come, India will witness a shift in trend with tall buildings being designed in **steel or composite structure**. **As more and more projects will be launched, it will help achieve economies of scale for developers and contractors.**



## Conclusion

India's aspiring growth in the real estate industry will be defined by its involvement in high-rise construction. With a combined effort of architects, engineers, contractors and support of developers and government policies, there is exponential opportunity in this sector. The time is ripe for our government to think progressively and devise norms for high-rise constructions, for faster and safer standards. We have the adequate resources and necessity to make most of this opportunity and escalate our urban skylines to the next level.





*Book Design & Print By*  
**FALCON GRAPHIC**  
M-2, A 42-44, Manushree Building  
Commercial Complex, Dr. Mukherjee Nagar,  
Delhi -110009  
Tel.: 011- 43108913  
Mob.: 9650289133, 9811218913



# Celebrating Construction Technology Year 2019-2020



सत्यमेव जयते

Government of India  
Ministry of Housing and Urban affairs  
**Central Public Works Department**

